

2011 SOFT - TIAFT



JOINT MEETING OF THE
SOCIETY OF FORENSIC TOXICOLOGISTS
&
THE INTERNATIONAL ASSOCIATION
OF FORENSIC TOXICOLOGISTS

PROGRAM & ABSTRACTS

25 - 30 SEPTEMBER 2011
MARRIOTT MARQUIS SAN FRANCISCO HOTEL
SAN FRANCISCO, CALIFORNIA, USA



25 September 2011

Dear Colleagues and Friends,

I am honored and privileged to welcome you to San Francisco, California for the 2011 Joint SOFT-TIAFT International Conference & Exposition on Forensic and Analytical Toxicology. Our gathering encompasses the 41st Annual Meeting of the Society of Forensic Toxicologists and the 49th Annual Meeting of The International Association of Forensic Toxicologists.

2011 is UNESCO's International Year of Chemistry and you could not have chosen a better way to celebrate than by participating in the 2011 Joint SOFT-TIAFT Meeting. This year we have broken every record in exhibitor participation, which ensures that you will see firsthand the best products, services and equipment that our extraordinary exhibitors have to offer. And with more than 500 submitted abstracts from dozens of countries, the final scientific program is guaranteed to both educate and inspire!

San Francisco is a colorful and breathtaking metropolis that has re-established itself as the economic and cultural hub of the American West following the 7.8 magnitude earthquake of 1906 that devastated the entire region and killed thousands. In 2011, 105 years after the earthquake, the City remains a beacon for visitors from around the world. From the famous icons of Golden Gate Bridge and Alcatraz Island to the Cable Cars and the exquisite art galleries at SFMOMA, the City takes pride in its unrivaled attractions, renowned museums, and unique neighborhoods that are treasures of their own. While in town, please take time to explore this wonderful 'left coast' urban destination and discover the incredible variety of sites, shops, and restaurants that define the City's great ethnic and cultural diversity.

As host of this year's conference - 15 years after attending my first TIAFT meeting in 1996 in Thessaloniki, Macedonia, Greece and 13 years after my first Joint SOFT-TIAFT meeting in 1998 in Albuquerque, New Mexico - I am reminded of the global success our field enjoys. Also reinforced is how supportive more seasoned forensic toxicologists are towards younger members, enabling us to aim high and reap the benefits of belonging to a large international family of colleagues and friends ready to assist, promote and help us succeed!

As Chairman of the 2011 Joint SOFT-TIAFT Meeting, I have had the privilege of working with an extraordinary Organizing Committee, a distinguished International Advisory Board and a myriad of volunteers from around the world. Their collective and tireless support and assistance during the last four years today permits us to provide you with a cutting-edge scientific program that represents the worldwide state-of-the-art in forensic and analytical toxicology. We are also proud of the rejuvenating social calendar that we hope all will find entertaining against the backdrop of this amazingly diverse City.

Welcome to San Francisco!

Nikolas P. Lemos, PhD, FRSC, D-ABFT
Chairman, 2011 Joint SOFT-TIAFT International Conference & Exposition on Forensic and Analytical Toxicology

Chief Forensic Toxicologist &
Director, Forensic Laboratory Division
Office of the Chief Medical Examiner
City and County of San Francisco

Clinical Professor
Department of Laboratory Medicine
School of Medicine
The University of California, San Francisco

2011 SOFT-TIAFT Organizing Committee

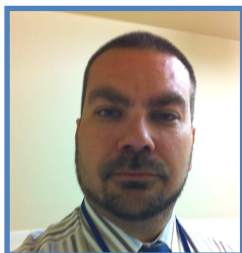

Nikolas P. Lemos
Committee Chairman & Host

Ann Marie Gordon
Co-Host

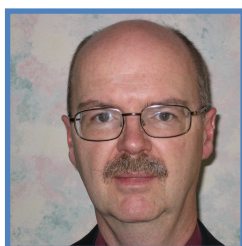
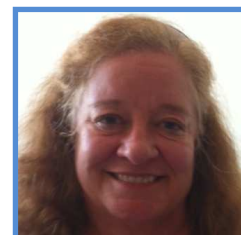

Daniel S. Isenschmid
Treasurer

Vina R. Spiehler
International Delegate Liaison



Marilyn A. Huestis
Scientific Program

Laureen Marinetti
Workshops



Dimitri Gerostamoulos
Workshops

Jeri Roper-Miller
Sponsors & Exhibitors



Peter R. Stout
Sponsors & Exhibitors

**SOFT
BOARD OF DIRECTORS**

**Sarah Kerrigan, Ph.D.
SOFT President**

**Marc A. LeBeau, Ph.D.
SOFT Vice President**

**Dan T. Anderson, M.S.
SOFT Secretary**

**Peter R. Stout, Ph.D.
SOFT Treasurer**

**Adam Negrusz, Ph.D.
Director**

**Fiona J. Couper, Ph.D.
Director**

**Jeri D. Roper-Miller, Ph.D.
Director**

**Jennifer F. Limoges, M.S.
Director**

**Bruce A. Goldberger, Ph.D.
Director**

**TIAFT
EXECUTIVE COMMITTEE**

**Olaf H. Drummer, Ph.D.
TIAFT President**

**Alain G. Verstraete, M.D.
TIAFT President-Elect**

**Pascal Kintz, Ph.D.
TIAFT Past President**

**Hee-Sun Chung, Ph.D.
TIAFT Secretary**

**Daniel S. Isenschmid, Ph.D.
TIAFT Treasurer**

**Marc A. LeBeau, Ph.D.
Board Member**

**Hans H. Maurer, Ph.D.
Board Member**

**Anya Pierce, M.B.A.
Board Member**

The 2011 SOFT-TIAFT Organizing Committee wishes to acknowledge the invaluable contribution made by dozens of SOFT and TIAFT members who assisted our distinguished International Advisory Board Members with the peer-review of submitted abstracts.

International Advisory Board Members

Dan T Anderson, MS - USA
Robert A Anderson, PhD - UK
Sotiris Athanaselis, PhD - Greece
Elisabetta Bertol, PhD - Italy
Jochen Beyer, PhD - Australia
Federica Bortolotti, MD, PhD - Italy
Jennifer Button, BS - UK
Hee-Sun Chung, PhD - Korea
Marc Deveaux, PhD - France
Olaf H Drummer, PhD - Australia
Simon Elliott, PhD - UK
Bradford R Hepler, PhD - USA
David W Holt, PhD - UK
Alan Wayne Jones, PhD - Sweden
Sarah Kerrigan, PhD - USA
Pascal Kintz, PhD - France
Thomas Kraemer, PhD - Switzerland
Robert Kronstrand, PhD - Sweden
Marc LeBeau, PhD - USA

International Advisory Board Members

Hans H Maurer, PhD - Germany
Manfred R Möller, PhD - Germany
Christine Moore, PhD - USA
Ashraf Mozayani, PhD - USA
Ilkka Ojanperä, PhD - Finland
David Osselton, PhD - UK
Frank T Peters, PhD - Germany
Simona Pichini, PhD - Italy
Anya Pierce, MBA - Ireland
Nikolaos Raikos, MD - Greece
Marina Stajic, PhD - USA
Osamu Suzuki, MD, PhD - Japan
Franco Tagliaro, MD - Italy
Helena Teixeira, PhD - Portugal
Alain G. Verstraete, MD - Belgium
Robert Wennig, PhD - Luxembourg
Sarah Wille, PhD - Belgium



2011 SOFT-TIAFT

SCHEDULE OF EVENTS

SUNDAY, 25 SEPTEMBER 2011

TIME	ACTIVITY	LOCATION
0700-1800	Registration Desk	North Registration
0700-1800	Internet Café	Yerba Buena Grand Assembly
0900-1130	TIAFT Board Meeting	Salon 10-12
0900-1300	NCD-COAD General Meeting	Walnut
1000-1300	Forensic Toxicology Council Meeting	Pacific E
1130-1230	TIAFT Regional Representatives Meeting	Salon 10-12
1230-1400	Young SOFT-TIAFT Lunch	Off Site – Buca di Beppo
1400-1830	Young SOFT-TIAFT Symposium	Salon 1,2,3,4
1400-1800	NLCP Inspector/Director Training	Golden Gate A
1900-2100	Young SOFT-TIAFT Happy Hour	Off Site - TBA

MONDAY, 26 SEPTEMBER 2011

TIME	ACTIVITY	LOCATION
0600-0000	Hospitality Room	Juniper
0700-1800	Registration Desk	North Registration
0700-0800	Continental Breakfast	Golden Gate Foyer
0730-0800	Sign In for Workshops 1, 2 and 3	Golden Gate Registration
0700-1800	Internet Café	Yerba Buena Grand Assembly
0800-1200	Workshop 1	Golden Gate A
0800-1200	Workshop 2	Golden Gate B
0800-1200	Workshop 3	Golden Gate C
0900-1200	FTCB Examinations	Sierra A
0900-1700	Exhibit Hall Set Up	Yerba Buena
1000-1030	Break	Golden Gate Foyer
1200-1330	Lunch for Workshop Attendees	Jessie Square (Between Hotel and Jewish Contemporary Museum)
1300-1330	Sign In for Workshops 4, 5 and 6	Golden Gate Registration
1330-1730	Workshop 4	Golden Gate A
1330-1730	Workshop 5	Golden Gate C
1330-1730	Workshop 6	Golden Gate B
1330-1630	FTCB Board Meeting	Pacific H
1500-1530	Break	Golden Gate Foyer
1730-1830	SOFT/AAFS Drugs & Driving Committee Meeting	Nob Hill C
1900-2200	Tier I Sponsors' Receptions	
	Agilent Technologies	Club Room
	Thermo Scientific	Foothill G

TUESDAY, 27 SEPTEMBER 2011

TIME	ACTIVITY	LOCATION
0600-0000	Hospitality Room	Juniper
0700-1800	Registration Desk	North Registration
0700-0800	Continental Breakfast	Golden Gate Foyer
0700-1200	SOFT Board Meeting	Pacific H
0700-1800	Internet Café	Yerba Buena Grand Assembly
0730-0800	Sign In for Workshops 7, 8 and 9	Golden Gate Registration
0800-1200	Workshop 7	Golden Gate B
0800-1200	Workshop 8	Golden Gate C
0800-1200	Workshop 9	Golden Gate A
0800-1200	ABFT Examinations	Sierra A
0900-1200	ABFT Accreditation Committee Meeting	Pacific C
0900-1700	Exhibit Hall Set Up	Yerba Buena
1000-1030	Break	Golden Gate Foyer
1200-1330	Lunch for Workshop Attendees	Jessie Square (Between Hotel and Jewish Contemporary Museum)
1200-1800	ABFT Board Meeting	Pacific C
1300-1330	Sign In for Workshops 10, 11 and 12	Golden Gate Registration
1330-1730	Workshop 10	Golden Gate B
1330-1730	Workshop 11	Golden Gate C
1330-1730	Workshop 12	Golden Gate A
1500-1530	Break	Golden Gate Foyer
1730-1830	DFSA Committee Meeting	Nob Hill C
1800	Sunshine/Rieders Silent Auction Opens	Yerba Buena
1800-1900	Happy Hour in Exhibit Hall	Yerba Buena
1800-1900	ABFT Certificant Reception	Sierra A
1900-2100	Welcoming Reception in Exhibit Hall	Yerba Buena
2100-2230	Elmer Gordon Forum	Golden Gate A and B
	Historical Lecture by Professor Robert Wennig	
	SWGTOX by Dr. Bruce Goldberger	
2230-0030	Nite Owl by Cerilliant	The View on the 39 th Floor

WEDNESDAY, 28 SEPTEMBER 2011

TIME	ACTIVITY	LOCATION
0600-0000	Hospitality Room	Juniper
0700-1530	Registration Desk	North Registration
0730-0830	Continental Breakfast	Golden Gate Foyer
0700-1530	Internet Café	Yerba Buena Grand Assembly
0830-1530	Exhibit Hall Open	Yerba Buena
0830-0940	Opening Ceremony & Plenary Session	Golden Gate A and B
1010-1155	Scientific Session 1	Golden Gate A
1010-1155	Scientific Session 2	Golden Gate B
1155-1340	Lunch & Poster Session 1 in Exhibit Hall	Yerba Buena
1340-1440	Scientific Session 3	Golden Gate A
1340-1440	Scientific Session 4	Golden Gate B
1440-1630	SOFT Business Meeting	Golden Gate B
1700-2300	Escape "TO" Alcatraz & San Francisco Bay Cruise	Board Buses on Mission Street

THURSDAY, 29 SEPTEMBER 2011

<u>TIME</u>	<u>ACTIVITY</u>	<u>LOCATION</u>
0600-0730	SOFT "Karla Moore" Fun Run/Walk	Meet in Juniper at 0530 hrs
0600-0000	Hospitality Room	Juniper
0700-1530	Registration Desk	North Registration
0730-0830	Continental Breakfast	Golden Gate Foyer
0730-0900	AAFS Steering Committee Meeting	Pacific H
0700-1800	Internet Café	Yerba Buena Grand Assembly
0830-1500	Exhibit Hall Open	Yerba Buena
0830-1030	Scientific Session 5	Golden Gate A
0830-1030	Scientific Session 6	Golden Gate B
1030-1100	Break	Yerba Buena and Golden Gate Foyer
1100-1200	Scientific Session 7	Golden Gate A
1100-1200	Scientific Session 8	Golden Gate B
1100-1200	Exhibitors' Feedback Meeting	Nob Hill B and C
1230-1400	Lunch & Poster Session 2 in Exhibit Hall	Yerba Buena
1300	Sunshine/Rieders Silent Auction Ends	Yerba Buena
1400-1530	Scientific Session 9	Golden Gate A
1400-1530	Scientific Session 10	Golden Gate B
1530-1600	Break	Golden Gate Foyer
1600-1800	TIAFT Business Meeting	Golden Gate B
1830-1930	Cocktail Reception	Yerba Buena Foyer
1930-0000	<i>Uniting Nations</i> Presidential Gala Dinner	Yerba Buena

FRIDAY, 30 SEPTEMBER 2011

<u>TIME</u>	<u>ACTIVITY</u>	<u>LOCATION</u>
0600-1600	Hospitality	Juniper
0700-1230	Registration Desk	North Registration
0730-0830	Continental Breakfast	Golden Gate Foyer
0700-1600	Internet Café	Yerba Buena Grand Assembly
0830-1030	Scientific Session 11	Golden Gate A
0830-1030	Scientific Session 12	Golden Gate B
1030-1100	Break	Golden Gate Foyer
1100-1230	Scientific Session 13	Golden Gate A
1100-1230	Scientific Session 14	Golden Gate B
1230-1400	Lunch & Poster Session 3	Salon 1 - 7
1400-1600	Scientific Session 15	Golden Gate A
1400-1600	Scientific Session 16	Golden Gate B
1600-1630	Break	Golden Gate Foyer
1630-1800	Award Presentations & Closing Ceremony	Golden Gate B



2011 SOFT-TIAFT

SCIENTIFIC PROGRAM

WEDNESDAY, 28 SEPTEMBER 2011

**2011 SOFT-TIAFT OPENING CEREMONY
GOLDEN GATE A AND B**

Moderators: Ann Marie Gordon and Nikolas P. Lemos

08:30-09:00

Welcoming Addresses: Professor Nikolas P. Lemos, Chairman & Host
The Honorable Edwin M. Lee, Mayor of San Francisco
Professor Sarah Kerrigan, SOFT President
Professor Olaf H. Drummer, TIAFT President

09:00-09:40

Plenary Session: "SAN FRANCISCO IN THE 1960s: SUMMER OF LOVE AND TOXICOLOGY"
Professor Thomas E. Kearny

09:40-10:10

BREAK

10:10-11:55

**Scientific Session on DUID
GOLDEN GATE A
Moderators: Michelle Spirk and Alain Verstraete**

**Scientific Session on Clinical Toxicology
GOLDEN GATE B
Moderators: Robert Kronstrand and Maria Martinez**

10:10-10:25

O1: Driving Under the Influence of JWH-018.
Montgomery

O12: Determination of Gamma-Hydroxybutyric Acid in Dried Blood Spots with "On Spot" Derivatization and GC-MS: Method Development, Validation and Application.
Ingels

10:25-10:40

O2: The prevalence of alcohol and drugs in seriously injured drivers in Belgium.
Verstraete

O13: Aminorex Poisoning in Cocaine Abusers?
Karch

10:40-10:55

O3: Oral Fluid Cannabinoids: Windows of Detection, and Sensitivity, Specificity and Efficiency of the Draeger DrugTest[®] 5000 after Controlled Smoked Cannabis Administration.
Huestis

O14: Towards a model for residual hazards from chemically contaminated human remains.
Noort

10:55-11:10

O4: DUID Case Involving "Legal High" Internet Drugs: Mephedrone, MDPV and Phenazepam.
Spirk

O15: UPLC-MS/TOF: An easy and fast Screening Method for Clinical Toxicology.
Henschel

11:10-11:25

O5: The Role of Legal Drugs in Serious Crashes.
Drummer

O16: The clinical utility of a comprehensive Time-of-Flight LC-MS serum drug of abuse panel in emergency intoxication cases.
Gerona

11:25-11:40

O6: A Model Drugged Driving Law.
Conboy

O17: Findings of MDMA and MDA in Hair, Blood and Urine by LC-ESI-MS/MS: Report of 11 Drug Facilitated Crime Cases with Anterograde Amnesia.
Deveaux

11:40-11:55

O7: Forensic Toxicological Investigations Concerning Motor Vehicle Drivers with a Suspended License: a Retrospective Five Year Review.
Argo

O18: A new degradation product of olanzapine.
Saar

11:55-13:40

LUNCH IN YERBA BUENA EXHIBIT HALL WITH POSTERS P001 - P100

Moderators: Gary Milman, Dayong Lee and Karl Scheidweiler

13:40-14:40

**Scientific Session on DUID
GOLDEN GATE A
Moderators: Christine Moore and Teemu Gunmar**

**Scientific Session on Postmortem Toxicology
GOLDEN GATE B
Moderators: Sarah Kerrigan and Trista Wright**

13:40-13:55

O8: Alcohol and Drugs among Randomly Selected Drivers.
Augsburger

O19: A case report of death by respiratory depression following methadone ingestion in an eleven-month-old boy – Accident or Child abuse?
Gilles

13:55-14:10

O9: Isomers of Fluoroamphetamines (FAs) Detected in Forensic Cases in Denmark.
Johansen

O20: An Epidemic of Fatal and Non-fatal Para-methoxymethamphetamine (PMMA) Intoxications in Norway.
Vevelstad

14:10-14:25

O10: Free and Glucuronide Conjugate Plasma Cannabinoid Pharmacokinetics After Ad Libitum Smoking of a 6.8% Δ^9 -Tetrahydrocannabinol Cigarette.
Karschner

O21: A Review of Deaths in Subjects Commencing A Methadone Maintenance Program – A 15 year follow up.
Pricone

14:25-14:40

O11: Status Update for ForensicDB: A Web-Accessible Spectral Database for Shared Utilization by Forensic Laboratories.
Moore

O22: Hug Drug or Thug Drug? The Reincarnation of MDMA in San Francisco Postmortem Cases: Five Years in Review (2006-2010).
Armenian

14:40-16:30

**SOFT BUSINESS MEETING
GOLDEN GATE B**

17:30-23:00

ESCAPE TO ALCATRAZ & SAN FRANCISCO BAY DINNER CRUISE

THURSDAY, 29 SEPTEMBER 2011

08:30-10:30	Scientific Session on Alternative Matrices GOLDEN GATE A Moderators: Marc Augsburger and Sarah Wille	Scientific Session on Postmortem Toxicology GOLDEN GATE B Moderators: W. Lee Hearn and Hee-Sun Chung
08:30-08:45	O23: Quantification of tetrahydrocannabinol in oral fluid collected with the StatSure, Quantisal or Certus device using UPLC-MS/MS. Wille	O43: Studies on the metabolism of three model drugs by fungi colonizing cadavers using LC-MS/MS and GC-MS analysis. Ramírez
08:45-09:00	O24: Abuse of benzodiazepines and/or zolpidem proved by hair analysis. Kim	O44: Demonstration of Postmortem Redistribution of 3,4-Methylenedioxyamphetamine and 3,4-Methylenedioxyamphetamine in A Case of Ecstasy Intoxication. Hearn
09:00-09:15	O25: Cannabinoids in oral fluid following passive exposure to marijuana smoke. Moore	O45: Influence of ante mortem perfusion on autopsy blood ethanol concentration. Kintz
09:15-09:30	O26: Rapid Method to Screen and Confirm Hair Ketamine and Metabolites in 1 Hour. Tsui	O46: Characterization of single nucleotide polymorphisms of cytochrome P450 in an Australian deceased population. Pilgrim
09:30-09:45	O27: Elimination Times for Drugs of Abuse in Oral Fluid from Patients with High and Repeated Intake - Case Examples. Øiestad	O47: Opioids in Fatalities. Ojanperä
09:45-10:00	O28: LC-HRMS method for determination of levamisole in hair: application to clinical samples. Nalesso	O48: Alcohol is associated with the partitioning of Morphine between blood and vitreous humour compartments in deaths associated with the use of Heroin. Stephen
10:00-10:15	O29: Oral Fluid Drug Testing of Chronic Pain Patients. Heltsley	O49: Benzodiazepine-like hypnotics in postmortem blood: Zopiclone- and zolpidem-related fatalities in Norway. Frost
10:15-10:30	O30: Developing Exhaled Breath as a Matrix for the Detection of Cannabinoids Beck	O50: Investigation of Markers to Indicate and Distinguish Death Due to Alcoholic Ketoacidosis, Diabetic Ketoacidosis and Hyperosmolar Hyperglycaemic State using Post-Mortem Samples. Paterson
10:30-11:00	BREAK	
11:00-12:30	Scientific Session on Clinical Research GOLDEN GATE A Moderators: Vina Spiehler and Nathalie Desrosiers	Scientific Session on Alcohol Biomarkers GOLDEN GATE B Moderators: Frank Musshoff and Dimitris Gerostamoulos
11:00-11:15	O31: Proteomic Profiles in Intrauterine Growth Restriction. Favretto	O51: Ethyl-glucuronide and ethyl-sulfate in placenta and fetal tissues by LC-MS/MS: biomarkers of transplacental ethanol transfer. Morini
11:15-11:30	O32: Concentrations of atomoxetine and its metabolites in oral fluid and matched plasma specimens. Pichini	O52: Detection of ethylglucuronide and ethylsulfate in dried blood spots. Hernandez Redondo
11:30-11:45	O33: Pharmacokinetics of tetrahydrocannabinolic acid A after intravenous administration. Wohlfarth	O53: Diagnostic Performance of Ethyl Glucuronide in Hair for the Investigation of Alcohol Drinking Behavior: A Comparison with Traditional Biomarkers. Sporkert
11:45-12:00	O34: In-vitro kinetics of the human cytochrome P450 isozyme catalyzed metabolism of the Aporphine Alkaloid Glaucine Using LC-MS ⁿ . Meyer	O54: Predicting Blood Alcohol Concentrations after Social Drinking in Human Subjects where Absorption may be Incomplete. Coward
12:00-12:15	O35: Urinary Excretion Kinetics of MDMA and its Phase II Metabolites Following Controlled MDMA Administration to Humans. Schwaninger	O55: Comparison of different markers of chronic alcohol abuse in the assessment of driving fitness. Poletti
12:15-12:30	O36: Cannabinoids in Expectorated Oral Fluid from Daily Cannabis Smokers During Prolonged Monitored Abstinence. Milman	O56: Liquid chromatography-mass spectrometry measurement of the alcohol biomarker phosphatidylethanol (PEth) in blood. Helander
12:30-14:00	LUNCH IN YERBA BUENA EXHIBIT HALL WITH POSTERS P101 - P200 Moderators: Golo Meyer, Sarah Himes and Rebecca Hartman	

THURSDAY, 29 SEPTEMBER 2011 (CONT.)

14:00-15:30	Scientific Session on Clinical & Preclinical Research GOLDEN GATE A Moderators: Pirjo Lillsunde and Daniel S. Isenschmid		Scientific Session of Analytical Toxicology GOLDEN GATE B Moderators: Osamu Suzuki and Kristopher Graf
14:00-14:15	O37: Pharmacokinetics of Single Dose Clonazepam in Whole Blood and Oral Fluid. Kronstrand		O57: Detection of plant alkaloids in fatalities: the advantage of general (non-targeted) screening. Elliott
14:15-14:30	O38: Extended Plasma Cannabinoid Excretion in Chronic Daily Cannabis Smokers During Sustained Abstinence. Bergamaschi		O58: One-year monitoring of nicotine use in sport: frontier between potential performance enhancement and addiction issues. Marclay
14:30-14:45	O39: Detection of Anabolic Steroid Testosterone in Equine Plasma and Urine after Controlled Administration to Horses. Negrusz		O59: Nano Ultra-Performance Liquid Chromatography Time-of-Flight Mass Spectrometry Multi-analyte Screening of Regulated Drugs and (un)known Biotoxins. Nielen
14:45-15:00	O40: The uPA+/+-SCID Chimeric mouse: a model for in vivo study of steroid metabolism. Lootens		O60: The use of Hybrid Linear Ion Trap LC-MS and UHPLC QTOF-MS in the detection of glucuronide metabolites in urine. Taylor
15:00-15:15	O41: In vitro metabolic studies using homogenised horse liver. Wong		O61: Semi-Quantitative Analysis in General Unknown Screening by Liquid Chromatography - Hybrid Quadrupole Time-of-Flight Mass Spectrometry (LC-QTOF-MS). Broecker
15:15-15:30	O42: Acute Oral 3,4-Methylenedioxymethamphetamine (MDMA) Effects on Immediate, Short Term and Delayed Memory. Hartman		O62: MALDI-Mass Spectrometric Imaging – Analysis of Cocaine and Metabolites in a Single Hair. Kraemer
15:30-16:00	BREAK		
16:00-18:00			TIAFT BUSINESS MEETING GOLDEN GATE B
18:30-19:30	COCKTAIL RECEPTION		
19:30-00:00	UNITING NATIONS PRESIDENTIAL GALA DINNER		

FRIDAY, 30 SEPTEMBER 2011

08:30-10:30	Scientific Session on Synthetic Cannabinoids GOLDEN GATE A Moderators: Ruri Kikura-Hanajiri and Giampietro Frison		Scientific Session on Analytical Toxicology GOLDEN GATE B Moderators: Hans Maurer and Ana de Castro
08:30-08:45	O63: Identification of the Major Metabolites of 6 Synthetic Cannabinoids Present in "Herbal Mixtures" in Human Urine Samples Using LC-MS/MS Techniques. Hutter		O85: The First Documented Case With Positive 1-(3-Trifluoromethylphenyl) Piperazine (TFMPP) Results at the Office of the Chief Medical Examiner, City and County of San Francisco, California. Karamanidis
08:45-09:00	O64: 'Spice' in oral fluid: LC-MS/MS identification of active compounds. Coulter		O86: Proof of Concept for a Comprehensive Method for Rapid Drug Screening of Whole Blood with UHPLC Accurate-mass TOF LC/MS. Guale
09:00-09:15	O65: Determination of a synthetic cannabinoid, JWH-018 and its metabolites in rat urine and hair samples using UPLC-MS/MS. Kikura-Hanajiri		O87: Universal LC-MS Library – Dream or Reality? Use of a new drug and metabolite library recorded on a LXQ linear ion trap for drug screening using QTrap instruments. Wissenbach
09:15-09:30	O66: Application of Liquid Chromatography-Tandem Mass Spectrometry for Identification and Quantification of 'Legal Highs' Active Components' in Blood. Tokarczyk		O88: Identification of New Amphetamine-Related Designer Drugs in Drug Seizures by means of GC-MS, GC-MS After Derivatization With 2,2,2-Trichloroethyl Chloroformate, and U-HPLC/HR-Orbitrap-MS. Frison
09:30-09:45	O67: Determination of 'Spice' Cannabinoids in Serum and Hair by Liquid Chromatography-Tandem Mass Spectrometry. Neukamm		O89: Qualitative and quantitative analysis of 4-methylmethcathinone (mephedrone) by DESI-MS. Stojanovska
09:45-10:00	O68: Quantitative Analysis of Synthetic cannabinoids JWH018, JWH073 and JWH250 in Routine Oral Fluid Specimens. Rana		O90: Death by "Bath Salts": Postmortem Tissue Distribution of MDPV Following Lethal Intoxication. Wyman
10:00-10:15	O69: Case Report: Synthetic Cannabinoid JWH-175, MDEA and MDA Involved Death in San Francisco. Gordon		O91: New trips on the block – A retrospective study in hair. Rust
10:15-10:30	O70: LC-ESI-MS/MS analysis of synthetic cannabinoids in serum: Experiences regarding the spectrum of compounds and long-term detectability from 900 forensic & clinical samples. Kneisel		O92: Studies on the CYP Isoform-Dependent Metabolism of the Cathinone-derived Designer Drugs 3-Fluoromethcathinone and 3-Bromomethcathinone Using LC-HRMS. Meyer
10:30-11:00	BREAK		
11:00-12:30	Scientific Session on Analytical Toxicology GOLDEN GATE A Moderators: Erkki Vuori and Michelle Schmidt		Scientific Session on Analytical Toxicology GOLDEN GATE B Moderators: Donata Favretto and Meagan O'Hehir
11:00-11:15	O71: Synthetic Cannabinoid Use: Experience with Urine Drug Testing. Kacinko		O93: A Dual Approach to the Unequivocal Diagnosis of Botulinum Toxin Exposure. van der Schans
11:15-11:30	O72: Development and validation of an LC-MS/MS method for the detection and quantification of designer drugs, amfetamines, benzodiazepines, opiates and opioids in urine using the turbulent flow technique. Schäfer		O94: Specific and rapid detection of drugs from oral fluid using paper spray ionisation tandem mass spectrometry. Parkin
11:30-11:45	O73: Prediction of Liquid Chromatographic Retention for Differentiating Structural Isomers. Tyrkkö		O95: Street Drug Availability – The Impact on Toxicology Laboratories. Akrill
11:45-12:00	O74: Combined Urine Drug Screening and Confirmation by Liquid Chromatography-Time-of-Flight Mass Spectrometry and Database Search Including Exact Mass Qualifier Ion(s). de Castro		O96: Fast and efficient quantification of 31 common drugs of abuse and benzodiazepines in whole blood using fully automated sample preparation and UPLC-MS/MS. Rasmussen
12:00-12:15	O75: In Vitro Stability of Cannabinoids and Cannabinoid Glucuronides in Authentic Whole Blood and Plasma Specimens Following Controlled Smoked Cannabis. Schwope		O97: 2-Nitro-MAM and 2-Nitro-Morphine: Potential Markers for Monitoring the Presence of Opiates in Urine Adulterated with Potassium Nitrite. Luong
12:15-12:30	O76: Fast Targeted Screening of 234 Drugs and Poisons in Urine Using LC/MS/MS. Beyer		O98: Are Negative Screen Results Due to "Below Cut-Off" Levels Really Negative? Wong
12:30-14:00	LUNCH IN SALON 1 - 7 WITH POSTERS P201 - P302 Moderators: Mateus Bergamashi, Caroline Betit and Marisol Castaneto		

FRIDAY, 30 SEPTEMBER 2011 (CONT.)

14:00-16:00	Scientific Session on Alternative Matrices GOLDEN GATE A Moderators: Olaf Drummer and Madeleine Montgomery	Scientific Session on Postmortem Toxicology GOLDEN GATE B Moderators: Thomas Kraemer and Bertrand Brunet
14:00-14:15	O77: Evaluation of Phosphatidylethanol concentrations in drinking experiments Gnann	O99: Postmortem peripheral blood fentanyl concentrations in 20 cases: analysis and comparison to prior studies. Lung
14:15-14:30	O78: Unusual Codeine-to-Morphine Ratio in a Hair Sample: Indicator for CYP2D6 Polymorphism? Baumgartner	O100: A Family Tragedy after Three Doses of Tylenol. Martz
14:30-14:45	O79: Investigating Prehistoric Hallucinogen Consumption: An Archaeological Case Study from Lipez, Bolivia. Miller	O101: 1,5-Anhydroglucitol and Methylglyoxal – New Post Mortem Marker for Glucose Metabolism Disorders? Hess
14:45-15:00	O80: Segmental hair analysis as a useful tool in assessment of prenatal exposure to diazepam. Senczuk-Przbylowska	O102: Use and abuse of amphetamine in Sweden - subject demographics, concentrations in blood in the living and the dead and the spectrum of other drugs used. Jones
15:00-15:15	O81: Simultaneous quantification of various drugs of abuse in oral fluid collected with the Statuore, Quantisal or Certus device using UPLC-MS/MS. di Fazio	O103: A Study on the Forensic Toxicokinetics of Popular Poisons in China. Yun
15:15-15:30	O82: Concentrations of Cocaine and Cocaine Metabolites in Oral Fluid After Drinking Coca Tea. Reichardt	O104: Postmortem Drug Screening by Non-Targeted and Targeted UPLC Mass Spectrometry Technology. Rosano
15:30-15:45	O83: Operation Paris: The Shannon Matthews Case. Chatterton	O105: Fatal methanol poisonings in Finland 2004 – 2010 with attention to formic acid concentrations. Viinamäki
15:45-16:00	ERA AWARD A4 O84: Δ^9 -Tetrahydrocannabinol (THC), 11-nor-9-carboxy-THC (THCCOOH), cannabidiol (CBD) and cannabinol (CBN) in oral fluid following controlled, smoked cannabis. Lee	O106: Distribution of Cannabinoids in Postmortem Specimens. Ingle
16:00-16:30	BREAK	
16:30-18:00	<u>PRESENTATION OF AWARDS AND 2011 SOFT – TIAFT CLOSING CEREMONY</u> GOLDEN GATE B Moderators: Ann Marie Gordon and Nikolas P. Lemos Closing Remarks: Professor Olaf H. Drummer, TIAFT President Professor Sarah Kerrigan, SOFT President Professor Nikolas P. Lemos, Chairman & Host	

WEDNESDAY POSTER PRESENTATIONS

	Analytical Toxicology	Presenting Author
P001	Analysis of Gamma-hydroxybutyric acid (GHB) in Urine Samples using Liquid Chromatography with Tandem Mass Spectrometry (LC-MS/MS)	Elian
P002	Simultaneous analysis of cardiac glycosides in blood and urine by thermoresponsive LC-MS-MS	Kanno
P003	Confirmation of Propoxyphene and Norpropoxyphene in urine by Laser Diode Thermal Desorption (LDTD)	Tremblay
P004	Confirmation of Methadone and EDDP in Urine by Laser Diode Thermal Desorption (LDTD)-Mass Spectrometry	Tremblay
P005	Direct and automated analysis of dried blood spots coupled with liquid chromatography-mass spectrometry	Déglon
P006	Rapid Isolation of Tetrahydrocannabinolic Acid A From <i>Cannabis Sativa</i> Using Flash Chromatography	Wohlfarth
P007	Analysis of Amphetamines and Cannabis by Head-Space APCI/ITMS	Yamada
P008	Synthesis of an isotopically labelled internal standard for THCA-A by reaction of Δ^9 -THC-D ₃ with magnesium methyl carbonate (MMC)	Roth
P009	Identification of xenobiotics in human plasma/serum using automated sample preparation, standardized high-performance-liquid chromatography, high resolution mass spectrometry and platform-independent libraries	Grobosch
P010	Proof of concept for a rapid and simple method for the analysis of amphetamines and psychotropic drugs in urine using high temperature vaporization and diffusion solid phase microextraction technique	Fujii
P011	Determination of Cocaine and Cocaine Metabolites in Single Hairs by the MALDI LTQ Orbitrap XL Instrument – Preliminary Results	Musshoff
P012	Development of an ELISA for detection of tapentadol in oral fluid and blood	Rodrigues
P013	A novel ELISA screen for detection of sufentanil in human body fluids	Rodrigues
P014	Development of an ELISA for detection of diphenhydramine in urine and blood	Rodrigues
P015	High Sensitive Detection and Analysis of Abused Codacet® (Acetaminophen-Codeine) by Surface-Ionization Methods	Khasanov
P016	Feasibility of Surface-Ionization Methods for Detecting Trace Amounts of Antidiabetic Preparations	Khasanov
P017	Development and validation of an LC-MS/MS method for the detection and quantification of designer drugs, amphetamines, cocaine, opiates and opioids in blood and serum	Ewald
P018	Development and Validation of a Novel Homogeneous Immunoassay for the Detection of Tapentadol in Urine	Wang
P019	Mix-mode TiO-C18 Monolith Spin Column Extraction and GC-MS Analysis for the Simultaneous Assay of Organophosphorus Compounds, Glufosinate and Glyphosate in Human Serum and Urine.	Saito
P020	A Validated Method for Simultaneous Screening and Quantification of 31 Drugs of Abuse in Whole Blood by Fully Automated SPE and UPLC-QTOF/MS	Dalsgaard
P021	Simultaneous determination of dimethyltryptamine and β -carbolines in plasma samples by LC-MS/MS	Oliveira
P022	Production of identical retention time and mass spectrum for D ⁹ -tetrahydrocannabinol and cannabidiol following derivatisation with trifluoroacetic anhydride	Paterson
P023	WITHDRAWN	
P024	Validated LC/MS Methods for the Determination of <i>Amanita phalloides</i> Toxins in Human Urine	Merová
P025	Detection and Analysis of 30 Compounds in Oral Fluid via Ultra High Pressure LC-MS-MS without Solid Phase Extraction	Guice
P026	Certification of Reference Materials: Purity Analysis of Morphine-3 β -D-Glucuronide by Quantitative NMR, Enzymatic Hydrolysis LC-MS/MS Assay, and Mass Balance Purity Factor	Jian
P027	A Combined Method for the Analysis of Barbiturates and 11-nor-9-carboxy- Δ^9 -THC in Urine by LC/MS/MS	Guice

P028	Development of an Advanced Toxicology Method Utilizing Turbulent Flow Technology	Pentis
P029	Enterprise LIMS Data Exchange in Clinical, Toxicology, and Public Health Laboratories	Ward
P030	Urine Barbiturate Analysis Using an Improved SPE Protocol and LC/MS/MS; Achieving Chromatographic Resolution of Isobaric Amobarbital & Pentobarbital	Rummel
P031	The Application of HILIC Stationary Phase in Analysis of Anticonvulsants in Whole Blood by Means of NPLC-MS/MS	Lechowicz
P032	Quantitative Analysis of Carboxy-THC in Urine Using UPLC [®] -MS/MS	Lee
P033	Analysis of Amphetamines and Ephedrines in Urine using Solid Phase Extraction and Direct Mass Spectrometry	Inoue
P034	Benefit from the use of Deconvolution Reporting Software (DRS) and the Forensic Toxicology DataBase Library combined with Retention Time Locking (FT-DBL-RTL) in toxicological screening with GCMS in a forensic laboratory.	Brede
P035	Evaluation of Solid-Phase Extraction Cartridges for the Quantification of THC-COOH in urine using Gas Chromatography-Mass Spectrometry.	Leong
P036	Simple Urine Screening for the Determination of Selected Benzodiazepines by Direct Injection LC/ESI-MS	Athanaselis
P037	Method Optimization for the GCMS Determination of Amphetamines and Amphetamine-like Derivates in Urine Using On-line Trifluoroacetylation	Fábián
P038	Analysis of drugs of abuse by GC-MS in dried blood spot sample matrix	Lillsunde
P039	Protein Adduct Based Biomarkers of Chemical Warfare Agents: Characterization of HN-2 and HN-3 Adduction of Model Peptides	Thompson
P040	High Mass Accuracy LC-MSMS Instrumentation with Improved Identification Software to Screen Compounds of Forensic Interest	Philippe
P041	Proof of Concept for Drug Screening Using a High Resolution Accurate Mass System	Wang
P042	Direct Screening of "Herbal Blends" for Synthetic Cannabinoids by Matrix-Assisted Laser Desorption Ionization-Time of Flight Mass (MALDI-TOF) Spectrometry	Gottardo
P043	A Rapid Sample Preparation Procedure Utilizing Hybrid Quadrupole Linear Ion Trap Mass Spectrometry Detection as an Analytical strategy for Controlled Drugs in Blood and Application to Forensic Cases in Ireland	Dowling
P044	Evaluation of Supported Liquid Extraction (SLE) for the Determination of Cannabis and Synthetic Cannabinoid Compounds in Blood	Dowling
P045	Analytical Reference Standards: Synthesis and Characterization of \pm -threo-Ritalinic Acid-D ₁₀ Hydrochloride	Marek
P046	Method Development for Enantiomer Separation of Minor Metabolites from Gamma-Hydroxybutyrate using Liquid Chromatography Mass Spectrometry	Kaplan
P047	Proof of Concept for Analysis of 120+ Drugs in Whole Blood using LC/MS/MS	Newland
P048	Pyrolysis of Fentanyl: Isolating Markers of Smoking Abuse	Nishikawa
P049	Simultaneous Solid Phase Extraction and GC/MS Quantitation of Cocaine, Cocaine Metabolites, Standard and Extended Opiates, and Opiate Metabolites from Whole Blood	Jellick
P050	A Simplified Approach to the Extraction of Amphetamines from Urine using Supported Liquid Extraction prior to UPLC-MS/MS Analysis	Jones
P051	A Novel Approach to the Simultaneous Extraction of 11-nor-9-carboxy- Δ^9 -THC (THCCOOH) and THCCOOH-Glucuronide from Urine using Supported Liquid Extraction prior to UPLC-MS/MS Analysis	Williams
P052	Extraction of Opioids from Urine using Supported Liquid Extraction prior to UPLC-MS/MS Analysis	Jones
P053	Reduction of Lorazepam to Delorazepam during Treatment of Urine Specimens with β -Glucuronidase Enzyme	Fu
P054	Liquid handling of whole blood in a fully automated sample preparation setup	Wederkinck Andersen
P055	Sensitive Determination of Amatoxins Using UPLC-MS-MS	Ishii
P056	New Tools for the Analysis of Cannabinoids in Blood	Baumann

P057	Development of an Analytical Method for the Simultaneous Detection of Abused Drugs, Their Metabolites and Common Adulterants in Blood by Precipitation and UPLC/MS/MS	Silva-Torres
P058	Development of Rapid LC/MS/MS-based Methods for Confirmatory Analysis of Opiates and Benzodiazepines	Stoll
P059	Construction of a LC-MS/MS Library for Screening 242 Drugs and Toxic Compounds	Zhang
P060	Identification and Quantification of 28 Drugs and Toxic Compounds in Blood, Urine and Gastric Content using LC-MS/MS	Liang

Clinical & Preclinical Research

Presenting Author

P061	Inhibition of 1, 4-butanediol metabolism in human liver <i>in vitro</i>	Bender
P062	Sublingual Buprenorphine Pharmacokinetics: Gender differences	Moody
P063	Distribution of Nalbuphine in Putrid Albino Rat Organs by HPLC-UV	Soliman
P064	The uPA ^{+/+} -SCID Chimeric Mouse: a Model for <i>in vivo</i> Study of Mibolerone Metabolism	Lootens
P065	Acute Administration of MDMA Induces Hepatocellular Damage, Oxidative Stress and Lipoperoxidation in Rat Liver	Karch
P066	Evaluation of <i>In Vitro</i> Metabolic Assay Systems for Common Drugs of Abuse	Schneider
P067	Effects of Ethanol on the Toxicokinetics of Methamphetamine in Rabbits	Wang
P068	Pharmacokinetic Drug-drug Interactions of MDMA with Methamphetamine in Brain	Fuchigami
P069	Effect of Co-Administration of MDMA and Methamphetamine on Dopamine and serotonin levels in rat brain	Ikeda

Synthetic Cannabinoids

Presenting Author

P070	Development of New Polyclonal Antibodies for the Screening of JWH Synthetic Cannabinoids and Metabolites	Benchikh
P071	JWH 250 Metabolite Identification and Reactive Metabolite Evaluation	Liu
P072	Identification of newly distributed designer drugs, synthetic cannabinoids and cathinone derivatives in Japan	Uchiyama
P073	Screening for K2/Spice: Monitoring JWH-018, 073, 081 and 250 and some prominent metabolites by HPLC-MS/MS	Dawson
P074	Capabilities of Ultra-High-Pressure Liquid Chromatography – High Resolution/High Accuracy Orbitrap Mass Spectrometry (UHPLC-HRMS) in Structural Characterization of New Amphetamine-Related and Cannabinomimetic Designer Drugs	Frison
P075	An Effective and Rapid Sample Preparation Using DPX-Polar Tips for the Detection of Synthetic Cannabinoids in Urine by LC/MS/MS	Dalvi
P076	Method Development for the Identification and Determination of Synthetic Cannabinoid Metabolites in Hydrolyzed Urine by LC/MS/MS	Rigdon
P077	Analysis of Synthetic Cannabinoids in Herbal Blends by GC Tandem Mass Spectrometry	Macherone
P078	Synthetic Cannabinoid Screening Assay in Urine Specimens by LC/MS/MS	Toivola
P079	Dose Dependent Disposition of the CB1 Agonist JWH-018 in the Mouse following Inhalation of the Herbal Incense “Buzz”	Amira
P080	Identification of the Synthetic Cannabinomimetic 3-(1-adamantoyl)-1-pentylindole: Another Chapter in the Cat-and-Mouse Game	Kneisel
P081	Severe intoxications after consumption of products containing synthetic cannabinoids – analytical findings versus clinical symptoms	Kneisel
YSMA AWARD A2	Synthetic cannabinoids in whole blood: observations from the first year of casework	Graf

Bath Salts**Presenting
Author**

P082	Bioanalytical Quantification of MDPV; a Paranoia Inducing Designer Stimulant	Alexy
P083	Multi-Target Screening for New Designer Drugs by LC-MS/MS	Ambach
P084	Ion Trap GC-MS/MS analysis of "Bath Salts" in biological samples	Honnold
P085	Development of a novel Benzylpiperazine ELISA assay for urine and blood	Rodrigues
P086	Improved GCMS Derivatization Techniques for Analysis of New Designer Drugs: Methylone, Ethylone, Butylone, Mephedrone, and Methedrone	Carrell
P087	Identification and Differentiation of Methcathinone Analogues by GC-MS	Tsujikawa
P088	Bizarre behavior and death following ingestion of MDPV ("Bath Salts")	Clay
P089	Determination of Cathinone Derivatives and Other Designer Drugs in Serum by Comprehensive LC-Triple Quadrupole MS/MS Analysis	Swortwood
P090	Stability of Cathinones in Whole Blood Samples	Sørensen
P091	A Newly Found Mephedrone Analogue – 4-Methylethcathinone Legally Dealt on the Czech and Slovak Drugs of Abuse Market	Vorisek
P092	Simultaneous Determination of Mephedrone, Methylone, MDPV, and Amphetamines in Urine by LC/MS/MS	Rigdon
P093	Early Detection of Methcathinone and Related Compounds in Blood and Urine	Fürmanova
P094	2-Diphenylmethylpyrrolidine (Desoxy D2PM): another pipradrol analogue	Puchnarewicz
P095	A Validated Quantitative Method for Analysis of MDPV and Mephedrone (Bath Salts) in Urine Using LC-MS/MS	Lu
P096	Concept for Methods for the Prompt Identification of New Psychoactive Substances	Rofe
P097	Fluoro-and Methyl-Ephedrine Metabolites in Routine Urine Testing for Designer Stimulants	Uralets
P098	Analysis for Mephedrone (4-Methylcathinone) in Rat Plasma and Rat Brain Homogenates by Liquid Chromatography-Mass Spectrometry	Andrenyak
P099	Routine Screening of Human Urine for 14 New Designer Stimulants Found in "Bath Salts" Using GC/MS	Rana
P100	WITHDRAWN	

THURSDAY POSTER PRESENTATIONS

	Postmortem Toxicology	Presenting Author
P101	Determination of blood cyanide in several poisoning cases	Minakata
P102	Histopathological evaluation of organs in cases of fatal pesticide poisoning	Kanchan
P103	Toxicokinetics and Detection of ACTP-Ester Residues in Goat Using HPLC	Sahu
P104	Homicidal Aluminium Phosphide Poisoning - A Case Report	Chandrakant
P105	Fatal poisoning with <i>Taxus baccata</i> : Quantification of paclitaxel, 10-deacetyltaxol, baccatin III, 10-deacetylbaccatin III and cephalomannine (taxol B) and of 3,5-dimethoxyphenol in post mortem body fluids by LC-MS/MS.	Grobosch
P106	WITHDRAWN	
P107	Concentration Distributions of <i>d,l</i> -Methadone in Peripheral Blood from Forensic Autopsies, DUID Suspects and Users of Illicit Drugs	Holmgren
P108	Internet – Assisted Suicide (with pharmaceuticals)	Rohde
P109	Detection of Pentobarbital in Teeth Recovered from Skeletonized Remains by Microwave Assisted Extraction and Gas Chromatography-Mass Spectrometry	Betit
P110	A fatal case of simultaneous ingestion of mirtazapine, escitalopram and valproic acid	Gerace
P111	Association Between Antipsychotic Drugs and Sudden Cardiac Death	Aknouche
P112	Evaluation of the i-STAT®1 handheld analyzer for postmortem vitreous humor chemistry analysis	Oles
P113	Screening and Confirmation of 29 Benzodiazepines and Hypnotics in Urine by LC-MS/MS	Liu
P114	Acute Toxicity by Hair Dye in Upper Egypt	Ahmed
P115	Fatal poisoning with <i>Aconitum napellus</i> , lethal thyroid storm or both?	Keller
P116	Hydrogen Sulphide and Cocaine: A Lethal Cocktail	Button
P117	Postmortem Toxicological Investigation of Alcoholic Ketoacidosis	Bosman
P118	Suicide by Asphyxiation due to Helium and Argon	Musshoff
P119	Preliminary Analysis of Distribution of Sulfonylureas in Tissues of Poisoned Animals	Ibragimova
P120	Postmortem Drug Concentration Ranges in Blood for the Non-Intoxicated State Compared to Commonly Cited Therapeutic Ranges in Serum	Linnet
P121	The Role of Methadone in Drug Related Deaths: the Italian Experience 2000-2010	Fucci
P122	Pilot Study: In Vitro Metabolic Effects of <i>Escherichia coli</i> on Cocaine and Fentanyl	Martindale
P123	Analysis of cyanide in biological specimens: a comparison between a color test and a validated headspace gas chromatography method and its application in a fatal intoxication case.	Souza Pelicão
P124	Liquid Chromatography/Time-of-Flight Mass Spectrometry Analysis on Post-mortem Blood Samples for Targeted Toxicological Screening	Josefsson
P125	Use and limitation of models for microbial ethanol production in post-mortem cases	Boumba
P126	Fatal mephedrone intoxication – a case report	Tokarczyk
P127	Investigations of codeine-related deaths should include concentrations of morphine and the morphine metabolites M3G and M6G	Frost
P128	Buprenorphine Related Deaths. Interpretation of post-mortem blood and urine levels	Seldén

P129	Suicide With bk-MBDB (Butylone): Clinical and Toxicological Findings	Klys
P130	The distribution of Doxepin and Sulpiride in a human poisoning death	Wei
P131	A Complex Case of Murder Involving Zolpidem	Pinorini-Godly
P132	6-Acetylmorphine of Unknown Origin in a Case of Morphine Overdose	Herndon
P133	Relationship Between Femoral Blood and Liver Fentanyl Concentrations in Cause of Death Determination	Kloss
P134	Fatal Consequences of Datura Poisoning in a Case of Robbery: Clinical, Toxicological and Forensic Features	Gilles
P135	Determination of barbiturates in postmortem whole blood sample using hollow fiber liquid-phase microextraction and GC/MS	Menck de Almeida
P136	The Relationship Between Ante- and Post-Mortem Amlodipine Concentrations in Whole Blood Versus Plasma	Button
P137	Fatal Methanol Intoxication - Two Exceptional Case Reports	Dally
P138	Development of drug identification and semi quantitative analytical program by gas chromatography-mass spectrometry based on drug patterns in autopsy cases of Korea	Kim
P139	Rapid Analysis of Liver, Muscle and Vitreous Humor Samples using the Randox Whole Blood Drugs of Abuse (DOA) Arrays for use as a Near-Body Screen During Autopsy.	McLaughlin
P140	Toxicological Screening of Human Hair after Exhumation: The Potential Interest of Insect Pupae	Humbert
P141	Barbitone (barbital) and death in the workplace	Puchnarewicz
P142	Poisoning Deaths in the Region of Epirus, North-Western Greece During the Period 1998-2010	Boumba
P143	Diving under the influence of drugs	Villain
P144	Determination of Δ^9 -Tetrahydrocannabinol and 11-nor- Δ^9 -Tetrahydrocannabinol-9-carboxylic acid Bile Concentrations and their Importance in the Investigation of Forensic Cases	Athanaselis
P145	Postmortem Hair Analysis Verifies Heroin Exposure and Leads to a Killer	Athanaselis
P146	Interpretation of High Blood Clozapine Concentrations - A Case Report	Athanaselis
P147	Methadone-Related Deaths: A Worrying Increase	Vignali
P148	Fatal Intoxication Due to Dichloromethane Exposure: a Case Report	Stramesi
P149	Unnatural Death Profiling in Cyprus: A Ten Year Study (2000-2010)	Liveri
P150	Influence of CYP2D6 and ABCB1 Gene Polymorphisms on the Disposition of the Enantiomers of Venlafaxine and O-desmethylvenlafaxine in Postmortem Femoral Blood	Karlsson
P151	Application of Enantioselective Analysis Combined with Genotyping: Implications for Interpretation of Postmortem Citalopram Levels	Kugelberg
P152	The use of pharmacogenetic analysis in forensic toxicology - Relation between <i>CYP2D6</i> genotype and ethylmorphine/morphine ratios in post mortem blood	Zackrisson
P153	Vitreous Humor as an Alternative Matrix in Forensic Toxicology	Brunet
P154	Evaluation and Comparison of Neogen [®] Corporation's Methadone / LAAM ELISA Kit with Postmortem Specimens	Simons
P155	Distribution of the Inhalant 1, 1-Difluoroethane (HFC-152a) in the Rat	Ochi
P156	Cocaine, Metabolites and Derivatives in Vitreous Humor Using Disposable Pipette Extraction Tips and Gas Chromatography-Mass Spectrometry	Peres

P157	Alcohol in Fatal Traffic Accidents in Espírito Santo, Brazil	Peres
P158	Enzyme-Linked Immunosorbent Assay (ELISA) Analytical Performance Validation for the Detection of 20 Drug Categories in Human Performance and Post-mortem Blood	Baker
P159	Enzyme-Linked Immunosorbent Assay (ELISA) Casework Performance Validation for the Detection of 20 Drug Categories in Blood	Razatos
P160	Enzyme-Linked Immunosorbent Assay (ELISA) Validation for Positive Cutoff Concentrations of 20 Drug Categories in Human Performance and Postmortem Blood Samples	Hwang
P161	Contribution of Alcohol and Drugs to Fatal All-Terrain Vehicle Accidents in West Virginia	Bailey
P162	Simultaneous Determination and Quantification of Nine Opioids in Blood, Plasma, and Tissue Homogenates Using Methoxyamine/MSTFA Dual Derivatization and Mini-Bore Fast GC/MS-EI SIM	Baker
P163	Strychnine - a fatal case in the UK	Puchnarewicz
P164	Fatal Drug Intoxications Involving Oxymorphone	Gebhardt
P165	Heroin overdose and myocardial damages: the relationship between toxicology and immunohistochemistry investigations in 95 cases	Busardò
P166	The analysis of gastric contents to discriminate between oral and intravenous administration of methamphetamine.	Busardò
P167	Comparison of Ketamine and Norketamine Levels in Bone Marrow following Acute and Chronic Ketamine Exposure	Betit
P168	Case Report: Clinical and Postmortem Findings in a Fatal Valproic Acid Poisoning	Lanaro
P169	Blood alcohol levels in suicide by hanging cases in the State of Sao Paulo, Brazil	Leyton
P170	Clozapine Overdose in an Embalmed Case	Ng
P171	Stimulant Drugs in Oral Fluid in the UK	Akrill
P172	Methadone Incidence in Medical Examiner's Cases in the City and County of San Francisco	Easterling

Workplace Drug Testing		Presenting Author
P173	Controlled Substances and Quotas. The impact of scheduling actions on Controlled Substances and the List I chemicals ephedrine, pseudoephedrine and phenylpropanolamine	Dang
P174	Detection of drugs of abuse in urine – do standard test panels cover the actual substances?	Dyrkorn
P175	Simple and Highly Efficient Drugs of Abuse Testing Methods by SPE and LC/MS/MS	Dioumaeva
P176	Utilization of GC-TOFMS and Automated Sample Derivatization for Forensic Urine Drug Testing by SAMHSA Guidelines	Heim
P177	Cannabis and cocaine detection in workplace drug testing in Italy	Santoro
P178	Analysis of 2008-2009 Urine Drug Testing Results from a Medical Review Officer Data Source	Baylor
P179	Analysis of Selected Drugs of Abuse and their Pyrolytic Products by LC/MS/MS	Oldfield
P180	Swiss Guidelines 2011 for Drugs of Abuse Testing	Binz
P181	UPLC [®] -MS/MS Method for SAMHSA Compliant Workplace Urine Drug Testing	Lee
P182	Anomalous Results of Morphine and 6-acetylmorphine in Urine Samples	Lewallen
P183	Workplace Drug Testing: Outcomes after One Year of Observation	Santoro
P184	Evaluation of the Randox Biochip Array Technology for the screening of drugs of abuse in urine	Polettini

P185	A Simplified Approach to the Extraction of Benzodiazepines from Urine using Supported Liquid Extraction (SLE) prior to LC-MS/MS Analysis.	Williams
P186	Interpretation of Lateral Flow Immunoassay Drug Test Results: Evaluation of the Drug Panel Reader	Gunnar
P187	Detection of Synthetic Urine in Workplace Drug Testing Specimens	Linden
P188	Specimen Validity Testing (SVT)- Analyzing pH, Creatinine Concentration and Specific Gravity in Korea	Ko
P189	WITHDRAWN	
P190	Potency of Illicit Cannabis in Japan	Takagi

Solid Doses		Presenting Author
P191	Frequency and Type of Synthetic Cannabinoids Analyzed in the Council of Forensic Medicine-Istanbul Narcotic Department, Turkey	Gürdal
P192	Prevalence and co-occurrence of active ingredients of 'legal highs'	Byrska
P193	Advanced LC-MS Approaches for the Detection of Synthetic Cannabinoids in Unknown Samples	Grabenauer
P194	Quantitation of Esterified and Non-Esterified Steroids in Oil-Based Injectables with SPE-UHPLC-DAD	Härtel
P195	Composition Analysis of "Legal Highs" by GC-EI-MS for Medico-Legal Purposes	Rojek
P196	Enantioseparation of Methylamphetamine by Capillary Electrophoresis: a Survey of the Synthetic Route of Methylamphetamine Samples Seized in the Australian Capital Territory (ACT)	Kelly
P197	A fast and inexpensive procedure for the isolation of synthetic cannabinoids from 'Spice' products using a flash chromatography system	Moosmann
P198	The Identification of Vapours from Illicit Cocaine Samples Using Static Head-Space Gas Chromatography Mass Spectrometry (HS-GC-MS)	Rofe
ERA AWARD A3	Evaluation of Inhomogeneity of K2 and Synthetic Cannabinoid products sold over the Internet	O'Hehir

Clinical Toxicology		Presenting Author
P199	RP-HPLC Determination of Benzhexol Hydrochloride in Tablet Formulations and Urine	Ahmed
P200	Acute Deliberate Organophosphate (Coumaphos) Poisoning with Intermediate Syndrome in a One Year Old Child	Kiat

FRIDAY POSTER PRESENTATIONS

Clinical Toxicology		Presenting Author
P201	Reporting Two Suicidal Fatalities Due to the Ingestion of Chlorfenvinphos Formulations: Simultaneous Determination in Tissues of the Pesticide and the Petroleum Distillates by GC-FID/GC-MS	Martínez
P202	Antidepressants in urine using the Triage® TOX Drug Screen fluorescent immunoassay followed by confirmation via direct injection LC-MS/MS	Banaszczyk
P203	Target screening of drugs from Dried Blood Spot samples based on LC-MS/MS and on-line desorption	Lauer
P204	Application of ultra high pressure liquid chromatography tandem mass spectrometry to the analysis of antiarrhythmic drugs in serum and plasma.	Thomas
P205	HIV/aids risk questionnaire accuracy to detect drug use in prison	Carvalho
P206	Validated method for the determination of Misoprostol Acid in whole blood by Ultra Performance Liquid Chromatography – Tandem Mass Spectrometry	Simões
P207	Validated method for quantitation of psilocin in plasma by LC-MS/MS and study of stability	Martin
P208	Thiethylperazine Intoxication in a Pregnant Woman in her 12th Week of Pregnancy	Ondrová
P209	Comparison of opioid analysis in whole blood and dried blood spots	Jantos
P210	Concentration Patterns of Buprenorphine and Metabolites, with and without Naloxone, in Human Urine	Carlisle
P211	Toxicological and Clinical Evaluation of Probationers for Marijuana Use in İzmir, Turkey	Akgür
P212	Development of a Colorimetric Assay Kit for the Measurement of Acetaminophen with Enhanced Precision and Assay Range on the Fully Automated RX Series Analysers	Bell
P213	Acute Poisoning by Slimming Capsules “Best Life”: Clinical and Analytical Data	Jamey
P214	Analysis of Oral Anti-diabetic Drugs and their Metabolites in Blood and Urine by Thin-Layer Chromatography	Ibragimova
P215	Analysis of Markers for Nicotine Exposure in Urine Specimens	Haglock
P216	In vivo Levamisole metabolism in humans	Bertol
P217	Toxicokinetics of Isopropanol, Acetone, Methyl ethyl ketone and Toluene Following an Overdose	Eysseric
P218	Fatal and non fatal methadone related intoxications in the region of Thessaloniki (Northern Greece)	Raikos
P219	Determination of Clenbuterol in Human Plasma and Urine by Liquid Chromatography Tandem Mass Spectrometry: Diagnosis of an Overdose in a Bodybuilder	Costa
P220	Persistent biomarkers for verification of exposure to organophosphate and organophosphothioate pesticides – a case study	van der Schans
P221	Case report of a Clozapine Intoxication of a 13-Month-Old Girl: Quantification of Clozapine and Its Main Metabolites in Serum and Urine Samples Over 11 Days	Wohlfarth
P222	Development of Two Monoclonal Antibodies for the Broad Detection of Barbiturates and for the Detection of Meperidine and the Metabolite Normeperidine	Benchikh

Clinical Toxicology		Presenting Author
P223	Application of Matrix Dedicated Evidence Biochip Array Kits to the Simultaneous Determination of Tricyclic Antidepressants (TCAs), Buprenorphine, Methylenedioxymethamphetamine (MDMA) and Other Drugs of Abuse in Urine and Blood	Piper
P224	Development of a Highly Sensitive Polyclonal Antibody for Measuring Lidocaine in Biological Samples	Lowry
P225	Use of anabolic-androgenic steroids in connection with violent crimes	Lood
P226	Observations on Methadone Co-Prescriptions and Non-Prescription Medications in a Pain Patient Population	West
P227	Characterization of Genetic Variants of Human Serum Transferrin	Santoro
P228	Validated analytical method for the determination of meta-chlorophenylpiperazine (m-CPP) in human plasma and urine by liquid chromatography-tandem mass spectrometry (LC-MS/MS)	Polesel

P229	The Relationship between Agouti-Related Protein (AgRP) and Leptin in Cannabis Smokers	Fathy
P230	Identification of Human Hepatic UDP-glucuronosyltransferases (UGTs) Involved in Metabolism of Ethanol	AlSaabi
P231	Production of Recombinant Hydroxyacid-oxoacid Transhydrogenase and its Application to Measure Gamma Hydroxybutyrate by a Colorimetric Assay	Alzeer
P232	WITHDRAWN	
P233	Forensic Aspects of Teargas Toxicity	Bendary
P234	Cross-Reactivity of Tapentadol Specimens with DRI [®] Methadone Enzyme Immunoassay	Collins
P235	WITHDRAWN	
P236	Quantitative U-HPLC-MS Analysis of 14 Benzodiazepines in Urine Using a High Resolution Accurate Mass Exactive Mass Spectrometer Equipped with a Higher Energy Collisional Dissociation Cell	He
P237	Urinary Levels of 1-Hydroxypyrene in Smoking and Nonsmoking Pregnant Women	Thiesen
P238	Imidazole Cyclodextrin (ImCD) as an Antidote for Cyanide Poisoning: <i>In Vitro</i> and <i>In Vivo</i> Results	Yamagiwa
P239	Methadone and Metabolites in Hair of Methadone-Maintained Pregnant Women and Their Infants	Himes
ERA AWARD AI	Oral Fluid and Plasma 3,4-Methylenedioxymethamphetamine (MDMA) and Metabolite Correlation after Controlled Oral MDMA Administration	Desrosiers

**Presenting
Author**

Alternative Matrices

P240	Validation of a solid phase extraction procedure for identification and quantification of cocaine, metabolites and derivatives in meconium using GCMS	Alves
P241	Mistreatment of Older People in a Retirement Home: Evidence of Chemical Abuse through Hair Analysis	Dumestre - Toulet
P242	Case Report of THC Identified in Pubic Hair Documenting Drug Use by a Public Authority Official	Aknouche
P243	Comparison Study of Oratect [®] Oral Fluid Drug Screen Devices for Amphetamine, Cocaine, Opiates, Methamphetamine, THC and PCP with LC/MS/MS Confirmation	Wang
P244	Evaluation of On-Site Oral Fluid Drug Screening Devices	Bott
P245	Percentages of N- and O-demethyl metabolites of tramadol in hair – Use for assessment of tramadol intake vs. external contamination	Madry
P246	Effect of reducing the cut-off concentration for opioids in oral fluid screening	Garnier
P247	Quality Control in Hair Analysis: The Society of Hair Testing Experience	Jurado
P248	GC-MS analysis of hair for the detection of drugs of abuse and their metabolites	Raikos
P249	Validation of a Simplified GC-MS Procedure for Confirmation of Oral Fluid On-Site Immunoassay Tests in a Program of Roadside Toxicological Screening of Drivers	Pascali
P250	Evaluation of Different Hair Color and Ethnicity Types Following Surface Contamination with Cocaine and Laboratory Decontamination	Bynum
P251	Simultaneous application of the Cozart [®] DDS801 and DrugWipe [®] 5 ⁺ oral fluid screening devices in an experimental procedure for roadside drug testing	Salomone
P252	Performance of Four Oral Fluid On-site Devices for Monitoring Drugged Driving Confirmed by UHPLC-MS/MS Analysis	Strano-Rossi
P253	Confirmation of Cannabinoids in Oral Fluid without Sample Pre-Treatment: UHPLC-MS/MS and SPME-GC/MS	Strano-Rossi
P254	Evidence of cathinone use through hair analysis using LC-MS/MS	Cirimele
P255	Concentration of Tramadol in Human Hair	Cirimele
P256	Comparison of Solid Phase Extraction versus Direct Analysis of Hair Extracts for Cocaine-N-Oxide by LC/MS/MS	Crawley

P257	Benzodiazepines in Oral Fluid: Effect of Screening Cut-Off Concentration	Coulter
P258	Hair analysis for estimation of exposure to methamphetamine and its related compounds	Nakashima
P259	UPLC-MS/MS Analysis of Drugs and Metabolites in Hair	Boone
P260	Screening of illicit drugs in hair with a combination of enzyme linked immunosorbent assay (ELISA) and enzyme multiplied immunoassay technique (EMIT)	Powles
P261	Detection of Phosphatidylethanol Species in Dried Blood Spots by LC-MS/MS	Faller
ERA AWARD A5	Investigation of Pyrolysis-Gas Chromatography/Mass Spectrometry (Py-GC/MS) as an Analytical Procedure for the Detection of Cocaine in Hair	Schmidt

**Presenting
Author**

Alcohol/Biomarkers

P262	A Study of Blood Alcohol Stability in Forensic Antemortem Blood Samples	Shan
P263	Chronic excessive alcohol consumption diagnosis: comparison between traditional biomarkers and ethyl glucuronide in hair in an authentic population	Morini
P264	Ethyl glucuronide by LC-MS/MS: Where are the limits?	Weinmann
P265	GC-MS/MS Method for the Measurement of Ethyl Glucuronide in Human Urine and Serum	AlSaabi
P266	Carbohydrate Deficient Transferrin: an Indication of Risk for Car accidents with Injuries	Bortolotti
P267	Detection of Ethanol Consumption Biomarkers (Ethyl Glucuronide and Ethyl Sulfate) in Saliva by LC/MS/MS	Guice
P268	Carbohydrate-Deficient Transferrin (CDT) as an Alcohol Biomarker: Influence of Age, Gender, Liver Disorders and Antiepileptic Medication	Loucka
P269	Assessment of Alcohol Intoxication via Visual Observations and Blood Alcohol Concentrations by the Widmark and Microdiffusion Methods	Uria Huaita
P270	Ethyl Glucuronide Concentrations in Pulverized and Cut Hair Samples	Albermann
P271	The Effects of Chemical Treatments on the Detection of the Alcohol Consumption Markers Ethyl Glucuronide (EtG) and Fatty Acid Ethyl Esters (FAEE).	Rowsell
P272	Influence of age, BMI and seasonal effects on ethylglucuronide concentration in hair	Salomone
P273	Alcohol Intoxication During a Drinking Experiment Based on Widmark's Equation	Gnann
P274	In vitro formation of phosphatidylethanol homologues after incubation with d ₆ -ethanol	Nalesso
P275	WITHDRAWN	
ERA AWARD A6	Comparison of Postmortem Vitreous Humor Ethyl Glucuronide Concentrations in Humans and Sprague Dawley Rats Following Ingestion of Ethanol	Wright

**Presenting
Author**

Sports Doping

P276	An Analytical Method for the Determination of Testosterone and Epi-Testosterone by Liquid Chromatography-Tandem Mass Spectrometry	Taylor
P277	GC-GC with Heart-cutting as a Simple and Rapid Sample Purification Method for GC-C-IRMS	Brailsford
P278	The Effect of Ethanol Ingestion on the Reliable Detection of Testosterone Doping in Sports	Vicente

DFSA		Presenting Author
P279	Importance of Packaging Analysis in Cases of Drug Facilitated Crimes	Aknouche
P280	Detection of GHB in Drug-Facilitated Sexual Assault Products on the Thailand-Myanmar Border	Suriya
P281	Detection of GHB and Related Substances in Urine Samples by Enzymatic Screen Followed by UPLC-MS/MS Confirmation	Keller
P282	Gas Chromatography- Mass Spectrometry Analysis of Benzodiazepines in Spiked Drinks under Different Storage Conditions	Gautam
P283	Urine Toxicology Findings in Alleged Drug Facilitated Sexual Assault Cases Over a Six-Year Period (2005-2010) in the City and County of San Francisco, California	Williams
P284	WITHDRAWN	

DUID		Presenting Author
P285	Profile of a drunk driver and recidivism risk factors. Findings on the prevalence and development of drunk driving from roadside testing in Uusimaa, Finland 1990–2008	Gunnar
P286	Phenazepam in Finland	Kriikku
P287	Prevalence of Licit and Illicit Drugs in Whole Blood among Danish Drivers in West Denmark	Andreasen
P288	Benzodiazepines, Zolpidem and Zopiclone among Drivers Suspected to be under the Influence of Drugs	Donze
P289	Driving under the influence of hypnotics and tranquilizers in the region of Bern, Switzerland –case data and a novel LC-MS/MS method.	Bernhard
P290	Analysis of cannabinoids in total blood samples by immunoassay screening and UPLC-MSMS confirmatory analytical method.	Castañera
P291	3,4-Methylenedioxymethamphetamine (MDMA) and Metabolites in Oral Fluid Collected with the Intercept® Device and by Expectoration Following Controlled Oral MDMA Administration	Scheidweiler
P292	Driving Under the Influence of Drugs: The England and Wales Perspective	Button
P293	Do DUI enforcement procedures miss drugs when alcohol is present in driving under the influence cases?	Lillsunde
P294	2-Amino-5-chloropyridine – a Potential Marker for Zopiclone Degradation in Forensic Cases	Nilsson
P295	Comparison of Illicit Drug Consumption in 1999 and 2009 in Individuals Suspected of Unfitness to Drive Due to Abusive Consumption of Drugs	Augsburger
P296	Proof of Concept for Automated SPE/HPLC/MS/MS Methods to Replace Traditional Immunoassay with MS Confirmation of Driving Under the Influence Samples	Sears
P297	Relationship between drug use and travel length among Brazilian truck drivers	Sinagawa
P298	Methadone and Driving in the City and County of San Francisco	Medina
P299	Felony Driving Under the Influence of Alcohol Cases over a Four-Year Period in San Francisco	Knight
P300	Misdemeanor Driving Under the Influence of Alcohol Cases over a Four-Year Period in San Francisco	Volk
P301	Evaluation of Alcohol and Psychoactive Substances in Blood Samples of Drivers Involved in Traffic Accidents	Acar
P302	Case Report of Driving Under the Influence of Drugs (DUID) with Mephedrone in France	Mazoyer



2011 SOFT-TIAFT

**YOUNG
FORENSIC TOXICOLOGISTS/SCIENTISTS
SYMPOSIUM**

SUNDAY, 25 SEPTEMBER 2011

<u>TIME</u>	<u>ACTIVITY</u>	<u>LOCATION</u>
1230-1400	Young SOFT-TIAFT Lunch	Off Site – Buca di Beppo
1400-1830	Young SOFT-TIAFT Symposium	Salon 1,2,3,4
1900-2100	Happy Hour	Thirsty Bear Brewery Co.

SYMPOSIUM AGENDA

1400 hrs	Welcome and Introductions	
1415 hrs	DUID Laws and Legislation in the US	Sarah Urfer (USA)
1430 hrs	International DUID Regulations	Sarah Wille (Belgium) and Jochen Beyer (Australia)
1515 hrs	Discussion	
1530 hrs	Emerging Drug Trends in the USA	Sherri Kacinko (USA)
1545 hrs	Break	
1615 hrs	Designer Drugs: An Update	Simon Elliott (UK) and Frank Peters (Germany)
1715 hrs	Discussion	

Presentations by 2010 TIAFT Young Scientist Award Winners

1730 hrs	Development of a Metabolite-Based LC-MSn Screening Procedure for Detection of Drugs and Their Metabolites in Urine	Dirk Wissenbach (Germany)
1745 hrs	Effects of Synthetic Cannabinoids on Electroencephalogram Power Spectra and Locomotor Activity in Rats	Nahoko Uchiyama (Japan)
1800 hrs	Discussion and Open Forum	
1900 - 2100 hrs	Happy Hour at Thirsty Bear Brewery Co.	

SOFT YOUNG FORENSIC TOXICOLOGISTS COMMITTEE

Teresa Gray (Chair)

Tim Grambow

Erin Karschner

Michele Merves

David Schwope

Jayne Thatcher

The SOFT Young Forensic Toxicologists (YFT) Committee, formed at the 2009 SOFT Annual Meeting, aims to foster young toxicologists' participation within SOFT, facilitate networking opportunities and promote training and educational events. With these goals in mind, the YFT committee will host three events at this year's Joint SOFT-TIAFT International Conference & Exposition on Forensic and Analytical Toxicology:

The first event will be the Young Forensic Toxicologists/Scientists Symposium, held Sunday afternoon in partnership with the TIAFT Young Scientists Committee. The symposium will provide information on DUID regulation and new drugs appearing in casework. There will also be several opportunities to network and exchange ideas with other scientists. Please see the schedule for additional details.

On Tuesday, in partnership with the SOFT Continuing Education Committee, the YFT Committee is hosting a workshop on expert witness testimony. The idea for this workshop came from suggestions at the 2010 YFT Symposium. We hope to receive suggestions for future workshops that will be of interest to our YFT membership at this year's event.

Finally, there will be an award for the best poster presented by a young toxicologist. Eligible posters will be displayed during the scheduled poster sessions on Wednesday through Friday. The young toxicologist with the best poster will receive complimentary registration to the 2012 SOFT Meeting in Boston. Good luck to all who participated!

TIAFT YOUNG SCIENTISTS (YS) COMMITTEE

Frank Peters (President; Germany)

Madeline Montgomery (Secretary; USA)

Jochen Beyer (Australia)

Federica Bortolotti (Italy)

Simon Elliott (UK)

Sooyeun Lee (Korea)

Helena Texeira (Portugal)

Sarah Wille (Belgium)

During the 2011 Joint SOFT-TIAFT International Conference & Exposition on Forensic and Analytical Toxicology, the TIAFT Young Scientists (YS) Committee is co-hosting the half-day Young Toxicologists/Scientists Symposium with the SOFT Young Toxicologists Committee on Sunday, 25 September, 2011.

During the Symposium, members of the TIAFT YS Committee will be lecturing on drugs and driving laws in their various countries and emerging drugs.

Two previous TIAFT YS Award winners (2010) will be sharing their research with the audience.

Additionally, the TIAFT YS Committee will be awarding the following three prizes at the meeting:

1. Best oral presentation by a Young Scientist during the 2011 SOFT-TIAFT conference,
2. Best poster presentation by a Young Scientist during the 2011 SOFT-TIAFT conference, and
3. Best scientific paper published during the previous year.

Awards will be presented on Friday, 30 September 2011 at the 2011 SOFT-TIAFT Closing Ceremony.

DIRECTIONS TO BUCA DI BEPPO

1. Exit the San Francisco Marriott Marquis Hotel using the Fourth Street Exit. (Go left as you exit)
2. Walk on Fourth Street past Mission Street.
3. Turn Right on Howard Street
4. Walk one-half city block to Buca di Beppo (855 Howard Street)

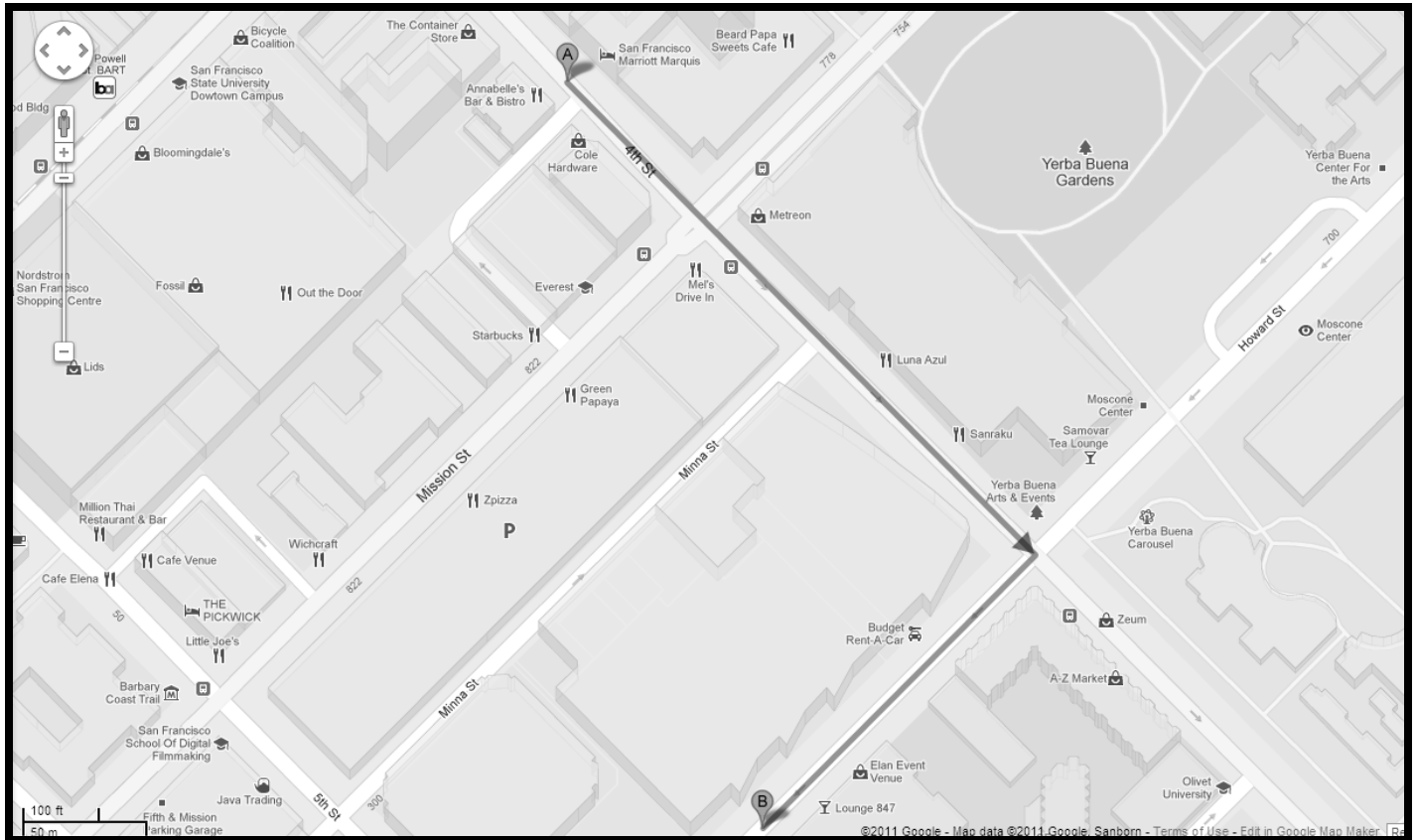

DIRECTIONS TO THIRSTY BEAR BREWERY CO.

1. Exit the San Francisco Marriott Marquis Hotel using the Fourth Street Exit. (Go left as you exit).
2. Walk on Fourth Street past Mission Street.
3. Turn Left on Howard Street.
4. Walk one and a half city block to Thirsty Bear Brewery Co (661 Howard Street).

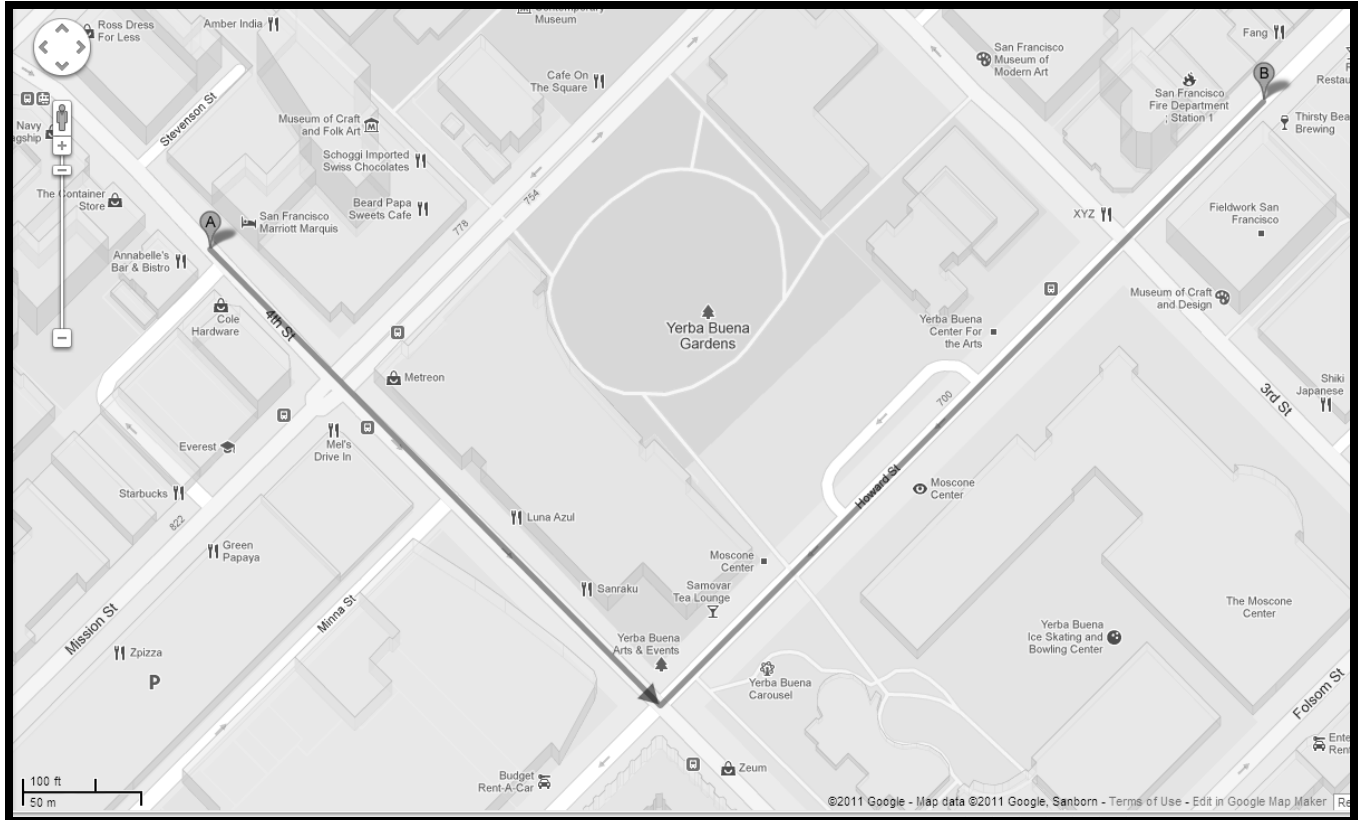

ABSTRACTS

HISTORICAL LECTURE
PART OF THE ELMER GORDON FORUM

Historical Lecture

HL1

The Violette Nozières Case (1933)

Professor Robert Wennig

Laboratoire National de Santé -Toxicologie, Université du Luxembourg, Luxembourg.

Violette Nozières was a 17-year-old girl living in Paris during the 1930's. She poisoned her parents with phenobarbital - an OTC at that time, pretexting an infectious disease requiring that the whole family should be treated on fictive recommendation by her physician. She tried to kill her parents for different reasons, later interpreted by her as a sexual assault of her father. Her mother survived in extremis but her father died. The autopsy # 1165/33 of Jean-Baptiste Nozières was performed by forensic pathologist Dr Charles Paul at the Institut Medico-Légal in Paris, directed by Prof Victor Balthazard from 1919 to 1941. Dr Paul was the usual partner of Commissaire Guillaume of the Parisian Police judiciaire from 36, Quai des Orfèvres, investigating in many famous criminal cases. The autopsy findings revealed multivisceral hemorrhagic congestions with cerebral and pulmonary oedema suggesting ingestion of a poison. The forensic toxicologist was Professor Emile Kohn-Abrest (1880-1963), an expert of outstanding reputation. Violette's case captivated and divided public opinion in France due to massive coverage by mass media generating a collective hysteria. Most people were not in favour of Violette, as their opinion was greatly influenced by several statements published in newspapers from famous psychiatrists, notably Clérambault, Heuyer and Magnus Hirschfeld, immigrated 1933 from Berlin. Some other people were in favour of Violette; they believed her incest story, notably several artists - the so called "Surrealists", living in Paris at that time, like André Breton, René Char, Paul Eluard, Maurice Henry, ELT Mesens, César Moro, Benjamin Péret, Gui Rosey, Salvador Dali, Yves Tanguy, Max Ernst, Victor Brauner, René Magritte, Marcel Jean, Alberto Giacometti, Jean Arp, Man Ray... So Violette was accused of patricide at a trial in Paris under emotional conditions. In 1934 she was convicted of murder by a first verdict on Octobre 12: sentenced to death by guillotine, than converted to lifelong imprisonment in 1942 under the Vichy regime; penalty commuted to 12 years imprisonment in 1945 and release from prison under condition in 1946: and finally definitive release and complete rehabilitation 1963 (and her name changed) with the help of efficient lawyers. Her story has been the matter of several books and in 1978 the matter of a movie by Claude Chabrol.

About the Speaker

Dr Robert WENNIG born 1942, studied chemistry in Luxembourg and Strasbourg where he obtained his PhD in 1970, was head of the Toxicology Department at the Laboratoire National de Santé until December 2009 in Luxembourg. In 1986 he received his Forensic Toxicologist certification from the German Society of Forensic Toxicology GTFCh. His academic career started as teaching assistant in 1965 at Strasbourg and Luxembourg in 1971, followed by a professorship in 1980 at Luxembourg University. He was in charge of GTFCh continuous education over many years and supervised post-graduate students at Strasbourg, Nancy and Metz

His research topics were focused on pesticides, drugs-of-abuse-bioavailability and biotransformation, chronic toxicity biomarkers, and wild mushrooms. He is author or co-author of more than 200 scientific articles or book chapters and was a platform presenter of more than 400 topics. He served in scientific societies: e.g as president of TIAFT; president of the Toxicological Society of Belgium and Luxembourg; vice-president of GTFCh; vice-president of the Medical Sciences Society in Luxembourg and as co-organizer of international meetings. He was a consultant to the EMCDDA in Lisbon; expert at the EMEA in London; to WHO in Geneva as IPCS national correspondent and his institute served as reference laboratory to the UNDOC in Vienna.

In 2005 he received the AS Curry Award from TIAFT; in 2010 the Grand Prix de la Société Française de Toxicologie Analytique, and in 2011 the Jean-Servais-Stas Award from the GTFCh.

ERA & YSMA
AWARD RECIPIENTS

ERA & YSMA Award Recipients

A1

Oral Fluid and Plasma 3,4-Methylenedioxymethamphetamine (MDMA) and Metabolite Correlation after Controlled Oral MDMA Administration

Nathalie A. Desrosiers*, Allan J. Barnes, Rebecca L. Hartman, Karl B. Scheidweiler, Erin A. Kolbrich-Spargo, David A. Gorelick, Robert S. Goodwin, and Marilyn A. Huestis
Chemistry and Drug Metabolism, IRP, NIDA, NIH, Baltimore, MD, USA.

Supported by the Intramural Research Program, NIH, National Institute on Drug Abuse

Objectives: Oral fluid (OF) is an excellent alternative matrix for monitoring drug intake in treatment, workplace, and driving under the influence of drugs (DUID) testing. One OF advantage for DUID, is a potentially closer correlation with plasma concentrations and intoxicating effects. There are no controlled MDMA administration studies characterizing OF/plasma ratios up to 143 h after controlled low and high MDMA oral administration doses.

Methods: Written informed consent was obtained for this IRB-approved, randomized, balanced, double-blind, within-subject drug administration study. After placebo, low (1.0 mg/kg), and high (1.6 mg/kg) oral MDMA doses, expectorated OF and plasma specimens were collected from -0.25-143h. Specimens underwent solid-phase extraction and were analyzed with electron impact 2D-GCMS for MDMA, 3,4-methylenedioxyamphetamine (MDA), 4-hydroxy-3-methoxymethamphetamine (HMMA), and 4-hydroxy-3-methoxyamphetamine (HMA) after acid hydrolysis. All limits of quantification (LOQ) were 5 ng/mL. Spearman's rho correlation was used to evaluate concentrations, and C_{max} and t_{max} were compared with Wilcoxon Signed Rank Test, (significance at $p < 0.05$).

Results: MDMA, MDA, HMMA, and/or HMA were quantified in 1162 of 1639 plasma specimens from 16 males and 10 females; only MDMA and MDA were present in 849 of 1251 OF specimens. In plasma and OF, MDMA concentrations were always higher than MDA levels, and MDA was never present without MDMA. OF/plasma ratios varied greatly (MDMA low 0.1-40.4, high 0.4-235.4; MDA low 0.7-17.1, high 0.9-24.3). Correlation coefficients for paired positive OF and plasma specimens were 0.79 (N=742, $p < 0.001$) for MDMA and 0.49 (N=416, $p < 0.001$) for MDA. 2 participants completed only 2 of 3 sessions. 16 participants underwent fMRI scanning 1.5 to 4 h after dosing to evaluate MDMA brain activity, precluding OF collection and excluding these data from some pharmacokinetic analyses. 8 subjects resided on the closed research unit for 143 h and provided all OF collections. Median time of first MDMA detection (t_{first}) was 0.5 h in plasma after both doses, and 0.5 and 0.75 h in OF after low and high doses, respectively. Median MDMA plasma C_{max} was 150 (132-218) for the low and 291 (250-387) ng/mL for the high dose, occurring 2.0 and 2.5 h after dosing. Median OF MDMA C_{max} were 1643 (1160-3382) and 4760 (2881-11,986) ng/mL. There was no significant difference in OF and plasma t_{max} ($p > 0.05$). Median last MDMA detection (t_{last}) was 29 h (23-39) after low and 43 (34-47) h after high doses in plasma, and 36.5 h (29-47) after low and 47 h (47-71) after high doses in OF. There were no significant differences in MDMA t_{first} between matrices ($p > 0.05$); MDMA t_{last} was later in OF compared to plasma ($p = 0.028$ for low and $p = 0.016$ for high dose), when only MDMA was considered. HMMA in plasma extended the window of detection of MDMA exposure.

Conclusions: OF concentrations and OF/plasma ratios exhibited large intra- and inter-subject variability, precluding prediction of plasma concentrations from OF levels. Ion trapping in the OF due to lower pH likely accounted for the higher OF concentrations as compared to plasma. OF is a useful matrix for monitoring MDMA exposure, with detection times of about 48 h after a high single MDMA recreational dose.

Keywords: MDMA, Oral Fluid, Pharmacokinetics

ERA & YSMA Award Recipients

A2

Synthetic Cannabinoids in Whole Blood: Observations From the First Year of Casework

Kristopher W. Graf*, Sherri L. Kacinko and Barry K. Logan
NMS Labs, Willow Grove, PA

Objectives: Synthetic cannabinoids first gained favor among drug users as a legal alternative to marijuana. As their use increased legislative bodies began working to control their distribution and sale. This research represents the first opportunity to analyze a large set of data to examine the prevalence and concentrations of some federally controlled substances with JWH-019 and JWH-250 in whole blood.

Methods and Materials: Data was extracted from the laboratory information management system; the initial evaluation included 159 cases analyzed at NMS labs between September 27, 2010 and March 31, 2011. Whole blood specimens were analyzed by a validated liquid chromatography-tandem mass spectrometric method for JWH-018, JWH-019, JWH-073 and JWH-250 in whole blood. The method is qualitative for JWH-019 and quantitative for the remaining three analytes with a limit of quantification (LOQ) of 0.10 ng/mL. The data was reviewed to evaluate 1) the demographics of synthetic cannabinoid users, 2) prevalence and concentrations of JWH-018, JWH-073, JWH-019 and JWH-250 in whole blood specimens and 3) trends of prevalence of analytes over time will be examined. The laboratory is currently analyzing an average of 10-15 cases a week so it is estimated that the final data set, including data through July 31, 2011, are expected to contain an additional 150-200 cases.

A total of 159 cases were available for examination. Of 129 cases in which gender was provided 112, (86.6%) were male. Ages ranged from 16-57 years with an average age of 25.1 years old. The distribution of analytes is displayed in Figure 1.

Results: Only three cases between February 25 and March 21, 2011 contained JWH-019. The positivity rate of JWH-018 appears to be stable (35-53%) and no positive JWH-073 cases were reported in February or March while the previous months had an average of 10% positive. Quantitative analyses were performed on 103 cases. Concentrations above the LOQ were reported for 46.6%, 7.7% and 12.6% for JWH-018, JWH-073 and JWH-250, respectively. The mean, median and range of concentrations for each analyte are depicted in Table 1.

Conclusions: This research was the first opportunity to examine a large set of data (N=159) and evaluate the prevalence, distribution and concentrations of JWH-018, JWH-073, JWH-019 and JWH-250 in whole blood. Based on the available data, these compounds are being used by males at a much higher rate than females and the average age of all users is 25.1 years. In general concentrations are low and a detection limit below 1 ng/mL increases the likelihood of a positive result. The final data set should include nearly twice as many cases which will offer the opportunity to do more robust analysis and to compare clinical and post-mortem cases.

Figure 1

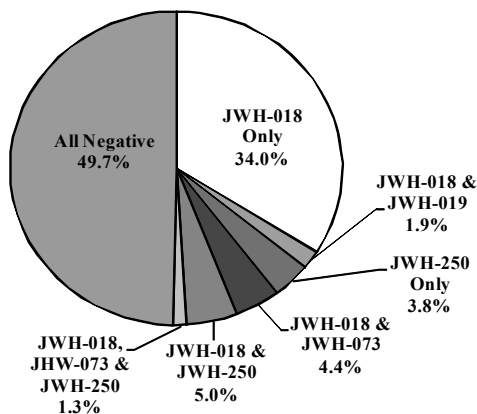

Table 1

	JWH-018	JWH-073	JWH-250
Range(ng/mL)	0.12 - 130	0.11 - 1.6	0.1 - 8.8
Mean (ng/mL)	5.2	0.6	1.5
Median(ng/mL)	1.0	0.3	0.6

Keywords: Synthetic Cannabinoids, Whole Blood, Casework

ERA & YSMA Award Recipients

A3

Evaluation of Inhomogeneity of K2 and Synthetic Cannabinoid Products Sold Over the Internet

C. Meagan O'Hehir^{1*}, Joseph Spera¹, Barry Logan^{1,2,3}, Francis Diamond³, and Jillian Yeakel^{1,2}

¹MSFS Program, Arcadia University, Glenside, PA; ²The Center for Forensic Science Research and Education, Willow Grove, PA;

³NMS Labs, Willow Grove, PA

Objective: The increasing variation of side effects exhibited by the smoking herbal incenses has led to the present study investigating the concentration of synthetic cannabinoids in the products.

Materials and Methods: The levels of JWH-018, JWH-073 and JWH-250 are determined quantitatively in various herbal incense products purchased online. Samples are extracted using a methanolic extraction followed by quantitation using Gas Chromatography Mass Spectrometry. The first experiment analyzed ground aliquots of 35 different herbal incense products solely to quantitate the synthetic cannabinoids present. Ground aliquots were prepared by grinding the herbal material between sheets of sandpaper. The second experiment analyzed both ground and unground aliquots of 34 additional products purchased at a later time. Ground and unground aliquots are analyzed to determine statistically significant variation both within products and between products. The limit of detection was determined experimentally to be 1 µg/mL, and a limit of quantitation of 2 µg/mL.

Results: Of the 35 initial products whose ground aliquots were analyzed, 86% contained JWH-018 in a range of 1-31mg/g, 34% contained JWH-073 in a range of 2-31mg/g, and 23% contained JWH-250 in a range of 2-77mg/g. Of the 34 products whose ground and unground aliquots were analyzed, 9% exhibited statistically significant variation of JWH-018 concentrations, while 41% exhibited statistically significant variation of JWH-250 concentrations, as indicated by a p-value of <0.05. This indicated that there was a lot of variation between the individual ground and individual unground aliquots of the samples analyzed. Therefore, the overall variation between the ground and unground is not significant. The results of the ANOVA test performed show that there was significant difference between all of the unground and all of the ground for each analyte in all of the packets. Therefore, the variations observed were not analyte dependent.

Conclusion: The overall variation of analyte concentrations was determined not to be statistically significant due to the variation among the individual ground and unground aliquots. This could correlate to the varying effects exhibited by users of these herbal incense products.

Key Words: Forensic Science, Synthetic Cannabinoids, JWH-018, JWH-073, JWH-250

ERA & YSMA Award Recipients

A4

Δ^9 -Tetrahydrocannabinol (THC), 11-nor-9-Carboxy-THC (THCCOOH), Cannabidiol (CBD) and Cannabinol (CBN) in Oral Fluid Following Controlled, Smoked Cannabis

Dayong Lee*, David M. Schwoppe, Garry Milman, Allan J. Barnes, David A. Gorelick and Marilyn A. Huestis.
Chemistry and Drug Metabolism, IRP, National Institute on Drug Abuse, NIH, Baltimore, MD

Supported by the National Institutes of Health, Intramural Research Program, NIDA

Introduction: Analytical advances in the simultaneous quantification of cannabinoids in oral fluid (OF) suggest approaches for determining recent cannabis smoking. As cannabis is the most commonly abused illicit drug, understanding its pharmacokinetics in OF is important for informed interpretation of test results.

Methods: Healthy 18-45 year old cannabis smokers using at least twice per month provided written informed consent for this Institutional Review Board-approved study, and resided in the secure research unit the evening prior to smoking. OF specimens were collected with the QuantisalTM device, 30 min before and up to 22 h after *ad libitum* smoking of a 6.8% THC cigarette. THC, THCCOOH, CBD and CBN were quantified by 2D-GC/MS. Limits of quantification (LOQ) were 0.5 ng/mL THC and CBD, 1 ng/mL CBN and 7.5 pg/mL THCCOOH.

Results: 10 subjects provided 80 OF specimens -0.5 h before and 0.25, 0.5, 1, 2, 3, 4 and 6 h after initiation of smoking; six stayed for an additional night providing specimens at 22 h. All 0.25 h, six 0.5 h, five 1 h and one 2 h specimen had insufficient OF volume based on Quantisal indicator failures, leading to underestimated cannabinoid OF concentrations. Prior to dosing, 4 subjects were positive for THC (range 2.0-13.6 ng/mL) and 9 for THCCOOH (11.8-359 pg/mL). THC concentrations were highly elevated for 1-2 h with medians (range) of 644 (68.0-10284), 212 (40.0-6362), 287 (18.9-2440) and 94.1 (16.0-519) ng/mL at 0.25, 0.5, 1 and 2 h, respectively. All specimens were positive at 6 h. Four of 6 subjects were still positive at 22 h (0.5-5.5 ng/mL). OF THCCOOH decreased more slowly with medians (range) of 74.4 (9.6-647), 111 (12.1-665), 42.4 (8.9-232), 47.5 (14.8-263) and 15.9 (0.0-103) pg/mL at 0.25, 1, 3, 6 and 22 h, respectively. 96% of subjects' OF specimens were THCCOOH-positive for 6 h; two 0.5 h collections were negative, likely due to insufficient sample volume. Five of 6 subjects were THCCOOH-positive at 22 h. Maximum CBD and CBN occurred within 0.5 h. CBD was last positive in 3 subjects at 6 h (0.6-2.1 ng/mL). CBN also rapidly decreased, and was positive in 4 subjects at 6 h (1.0-4.4 ng/mL). THC and CBD ($r=0.994$; $p<0.001$) and CBN ($r=0.985$; $p<0.001$), but not THCCOOH ($r=0.088$; $p=0.588$), were strongly correlated immediately after smoking (0.25-2 h). At the Substance Abuse and Mental Health Services Administration (SAMHSA) proposed 2 ng/mL THC cutoff, all subjects were positive at 6 h and two at 22 h. We proposed a cutoff of $\text{THC} \geq 2$ ng/mL and $\text{THCCOOH} \geq 20$ pg/mL to reduce the possibility of potential environmental cannabis smoke contamination. At this cutoff, 9 subjects' window of detection was <22 h, while one remained positive. With an alternate cutoff of $\text{THC} \geq 2$ ng/mL and $\text{CBD} \geq 0.5$ ng/mL or $\text{CBN} \geq 1.0$ ng/mL, the last positive OF test was ≤ 6 h. With $\text{THCCOOH/THC} \leq 4$ pg/ng, OF cannabinoid tests were positive ≤ 6 h, except for one at 22 h.

Conclusions: THC and THCCOOH were detected in OF for at least 22 h, while CBD and CBN were positive for at least 6 h at the method's LOQs. Additional research is needed to define the times of last detection. Controlled cannabis administration provides a scientific database establishing appropriate OF cutoffs and informing test interpretation.

Keywords: Oral Fluid, Tetrahydrocannabinol, Cannabinoids

ERA & YSMA Award Recipients

A5

Investigation of Pyrolysis-Gas Chromatography/Mass Spectrometry (Py-GC/MS) as an Analytical Procedure for the Detection of Cocaine in Hair

Michelle L. Schmidt* and Lawrence Quarino
Cedar Crest College, Allentown, PA, USA

Objectives: There is a long list of analytical procedures used to analyze hair for the presence of drugs, but many are labor intensive and time inefficient. The objective of this study was to determine whether the use of Py-GC/MS is advantageous compared to existing methodologies by primarily reducing sample preparation and analysis time.

Materials and Methods: Solutions of cocaine and two of its metabolites, cocaethylene and ecgonine methyl ester, were obtained and analyzed using GC/MS and Py-GC/MS. Based upon the results, five pyrolysis compounds were chosen: anhydroecgonine methyl ester (AEME), 3-ethoxy-4-methoxyphenethylamine, ecgonine methyl ester (EME), cocaine (COC), and cocaethylene (CE). Ions from each compound were chosen and screened using selected ion monitoring (SIM) to increase sensitivity. Ions 152, 166, and 181 were chosen for AEME; ions 138, 166, and 195 for 3-ethoxy-4-methoxyphenethylamine; 96, 182, and 199 for EME; 181, 182, 272, and 303 for COC, and 196, 212, 272, and 317 for CE. The qualitative limit of detection for AEME, 3-ethoxy-4-methoxyphenethylamine, EME, COC, and CE were 0.1, 0.1, 0.50, 0.05, and 0.05 ng, respectively for GC/MS, and 0.1, 0.1, 50, 25, and 10 ng, respectively for Py-GC/MS when analyzing the three drug solutions. The values obtained were based upon the least sensitive ion, meaning when one ion was no longer detected, the qualitative limit had been reached.

Results and Conclusion: The utility of Py-GC/MS with SIM for the aforementioned ions to detect cocaine in hair was investigated using multiple samples of cocaine-positive hair obtained from Willow Laboratories (Lynn, MA). After using a dichloromethane and a water wash to rid the hair of external contamination, several sample preparation methods were investigated, including a proprietary method from Willow Laboratories, the use of reducing agents such as DTT and ProK, grinding the hair via liquid nitrogen, and a method in which the hair was frozen in acetonitrile and thawed for five cycles. The latter method proved capable of detecting all four ions for cocaine in hair via both GC/MS and Py-GC/MS. In this method the hair was cut into 2-5mm sections, weighed, washed as previously stated, covered completely in acetonitrile, frozen and thawed for five cycles, and evaporated until a minimal amount of liquid remained for analysis. Py-GC/MS produced results with this method using 10 μ l of liquid; however, it was proven to be less sensitive than GC/MS which used 2 μ l, and thus was not investigated further. Utilizing the freeze/thaw method, GC/MS can provide results with as little as 10mg of hair, though 20mg is recommended due to a significant decrease in the abundance levels of cocaine and its ions from 20 to 10mg. A blind testing study with twelve samples from Willow Laboratories provided results that were consistent with those obtained by Willow Laboratories. Thus, this freeze/thaw method via GC/MS analysis produces results which are easily interpreted and is a viable method that significantly decreases the sample preparation and analysis time to several hours for the detection of cocaine in hair as opposed to methods such as ELISA which can take multiple days to complete.

Key Words: Hair, Cocaine, Pyrolysis-Gas Chromatography/Mass Spectrometry

Comparison of Postmortem Vitreous Humor Ethyl Glucuronide Concentrations in Humans and Sprague Dawley Rats Following Ingestion of Ethanol

Trista H. Wright^{1,*} and Kenneth E. Ferslew¹

¹Section of Toxicology, East Tennessee State University, Box 70422, Johnson City TN, 37614, USA

Introduction: Ethyl glucuronide (EtG) is a minor ethanol (Et) metabolite that confirms the absorption and metabolism of Et after oral or dermal exposure. Human data suggests maximum blood EtG concentrations are reached between 3.5 and 5.5 hours post oral Et administration (Hosieth, 2007). Keten et. al. (2009) determined that vitreous humor EtG (VHEtG) was detectable in 19 postmortem cases by liquid chromatography-mass spectrometry and that there may be a relationship between VHEtG and urine EtG (UEtG) concentrations. Our study was undertaken to determine if EtG is detectable in the VH of the Sprague Dawley (SD) rat, as well as the onset and magnitude of VHEtG detection after a single high oral Et dose.

Method: Blood, urine, and VH were quantitated for Et by direct injection gas chromatography (Perkin Elmer, GC-FID, Restek Rtx BAC-1 column) and EtG was semiquantitated by enzyme immunoassay (Microgenics Corp., Thermo Fisher Scientific) performed on Viva-E analyzer (Siemens). Limits of quantitation for BEtG was determined to be 50 ng equivalents/mL and UEtG and VHEtG to be 20 ng equivalents/mL. The limit of detection was determined to be 15 ng equivalents/mL for BEtG, UEtG, and VHEtG. Preliminary investigation was performed using female, SD rats gavaged with a single high dose of Et (4g/kg) followed by euthanasia from 0.25 to 3 hours post Et administration. While Et was detectable in blood, urine and VH within 0.25 hours of administration of Et, VHEtG was first detected at 1 hour post administration of the single high dose of Et and not consistently detected over the duration of the experiment with a limit of detection of 15 ng equivalents/mL. Based on preliminary findings in the female SD rats, thirty male SD rats were gavaged a single high Et dose (4g/kg) and placed in metabolic cages to determine the onset and magnitude of EtG distribution into VH and the extent of Et to EtG biotransformation and urinary excretion. We analyzed 25 autopsy cases for Et and EtG. Our autopsy and rodent data were then compared with the data by Keten to determine if there was a relationship between biological EtG concentrations and consequently the ability to predict EtG concentrations in unavailable postmortem specimens.

Results: The frequency of positive VHEtG concentrations in rats increased as Et was biotransformed to EtG after a single high oral ethanol dose, resulting in positive VHEtG concentrations in 2 of 6 after 1 hour, 4 of 6 after 2 hours and 6 of 6 after 3 hours. Maximum blood Et (BEt), urine Et (UEt), and vitreous humor Et (VHEt) concentrations were reached at 2 hours while maximum BEtG, UEtG, and VHEtG were reached after 6, 4, and 3 hours, respectively. BEt, UEt, and VHEt concentrations were 243 ± 18 mg/dL, 255 ± 44 mg/dL, and 250 ± 30 mg/dL while BEtG, UEtG, and VHEtG concentrations were 1038 ± 344 ng equivalents/mL, 774 ± 251 ng equivalents/mL, and 80 ± 18 mg equivalents/dL ($X \pm SEM$). BEt concentrations for the 25 autopsies ranged from a single drink to lethal BEtG levels and BEt:BEtG ratio (g/L:mg/L) ranged from 0.7 to 105. Results for our SD rat experiment and postmortem cases indicate that Et and EtG relationships are not associated enough to predict unavailable specimen concentrations.

Conclusion: Our rodent and autopsy data corroborates previous blood and urine EtG pharmacokinetic studies (Kharbouche, 2010; Wright, 2010) and has shown the SD rat to be a viable investigative model for postmortem toxicology of EtG.

Key Words: Vitreous, Ethyl Glucuronide, Rat, Postmortem, Ethanol

ORAL/PLATFORM
PRESENTATIONS

ORAL 1 – ORAL 106

Driving Under the Influence of JWH-018

Madeline A. Montgomery*, Louis J. Reda, and Marc A. LeBeau

Objectives: The objective of this presentation is to share a case report involving the synthetic cannabinoid, JWH-018, and its effects on impairment of a driver.

Materials and Methods: Evidence of a suspected DUI case, including plant material, a pipe, and urine from a driver, were submitted to the laboratory for synthetic cannabinoid analysis. The case involved a 16-year-old who was witnessed driving through several stop signs, and traveling in excess of 70 mph in a 25 mph zone before crashing into a train. He reported a short period of memory loss that ended when he struck a “hard” object. He also reported nausea, and being in a dream-like state, but that driving fast made him feel better. Further, he reported taking two hits of what he thought was marijuana from a homemade pipe just before he started driving. Friends that were smoking with him described him as crazed, and stated that he ignored them when they told him not to drive. Hospital urine testing for all routine drugs-of-abuse was negative.

Drug paraphernalia was extracted with methanol. Methanol extracts were screened using Direct Analysis in Real Time (DART) Time-of-Flight Mass Spectrometry (TOF-MS). After enzyme hydrolysis, urine samples were extracted via a simple liquid/liquid extraction. Drug and urine extracts were analyzed by liquid chromatography/mass spectrometry/mass spectrometry (LC/MS/MS) using high resolution mass spectrometry (HRMS).

Results: Method validation was performed qualitatively. The instrumental limit of detection (LOD) for drug samples via LC/MS/MS was determined to range from 0.01 – 1 mcg/mL for nineteen different synthetic cannabinoids. LODs of 1 ng/mL were determined for 11 different JWH-018 and JWH-073 metabolites in urine. The LOD for JWH-018 2-hydroxy in urine was 5 ng/mL. No interferences were noted in ten blank urine samples or urine samples containing common drugs of abuse. Average ion suppression for each analyte in urine was between 5-25%.

JWH-018 was identified in both the plant material and in residues from the pipe. Metabolites of JWH-018 were identified in urine collected from the driver a few hours after the accident.

Conclusions: JWH-018 has been associated with a serious automobile accident involving a teenage driver. The driver reported being in a dreamlike state, with some memory loss, and nausea. Observers described the driver as crazed and driving very erratically.

Key Words: JWH-018, DUID, Synthetic Cannabinoids

The Prevalence of Alcohol and Drugs in Seriously Injured Drivers in Belgium

Sara-Ann Legrand, **Alain Verstraete***

Department of Clinical Chemistry, Microbiology and Immunology, Ghent University, De Pintelaan 185, Ghent, Belgium

Disclaimer: This abstract has been produced under the project “Driving Under the Influence of Drugs, Alcohol and Medicines” (DRUID) financed by the European Community 6th Framework Program. This abstract reflects only the author's view. The European Community is not liable for any use that may be made of the information contained therein.

Objective: To determine the prevalence of alcohol and (il)licit drugs in seriously injured drivers in Belgium.

Methods: Injured drivers admitted to the emergency units of five hospitals from January 2008 to May 2010 were included. Blood samples were taken and analyzed for ethanol (enzymatic method) and 32 other psychoactive substances (UPLC-MS/MS or GC-MS).

Results: Of the 1078 injured drivers, 37% were found positive for one or more substances. The % drivers of the different vehicle types which were positive for the different substances are given in the table

	Car	Van	Motorcycle	Moped	Bicycle	Bus, truck	Total
n	353	24	159	96	413	22	1078*
None	48.4	62.5	69.2	49.0	75.3	90.9	60.9
Alcohol ($\geq 0.1\text{g/L}$)	42.2	29.2	18.2	27.1	16.2	4.5	26.3
Alcohol ($\geq 0.5\text{g/L}$)	37.7	25.0	15.7	27.1	13.3	4.5	23.2
Benzodiazepines	7.4	4.2	3.8	8.3	4.6	4.5	5.8
Cannabis (THC)	6.8	12.5	5.0	13.5	1.9	0.0	5.4
Antidepressants	5.7	0.0	3.8	9.4	4.6	0.0	5.0
Z-drugs	1.7	0.0	0.0	1.0	0.7	0.0	3.2
Opiates & opioids	3.1	4.2	3.8	2.1	3.6	0.0	3.2
Amphetamines	1.7	12.5	1.3	0.0	0.5	0.0	1.3
Cocaine	1.4	12.5	0.0	0.0	0.2	0.0	0.8

* 11 ‘other’ vehicles are not shown in the table.

Alcohol was found most frequently ($\geq 0.1\text{g/L}=26.3\%$; $\geq 0.5\text{g/L}=23.2\%$), followed by benzodiazepines (5.8%), THC (5.4%) antidepressants (5.0%), Z-drugs (3.2%) and opiates (3.2%).

The lowest percentage of positives was found in truck and bus drivers, followed by bicycle and motorcycle riders. Alcohol was most prevalent among drivers of personal cars, while the % positive for THC was the highest in moped drivers. Although absolute numbers were low, a high prevalence of illicit drugs was observed in van drivers.

In general the number of positive drivers was higher during nighttime and during weekends than during weekdays.

Conclusions: Alcohol and/or drugs were detected in more than half of the car drivers. Large differences in prevalence were seen between the drivers and riders of the different vehicle types.

Key Words: Prevalence Alcohol/Psychoactive Substance, Injured Drivers, Belgium

Oral Fluid Cannabinoids: Windows of Detection, and Sensitivity, Specificity and Efficiency of the Draeger DrugTest® 5000 after Controlled Smoked Cannabis Administration

Nathalie A. Desrosiers, David M. Schwoppe, Dayong Lee, Garry Milman, David A. Gorelick and **Marilyn A. Huestis***
Chemistry and Drug Metabolism, Intramural Research Program, National Institute on Drug Abuse, NIH, Baltimore, MD, USA

Supported by the Intramural Research Program, NIH, National Institute on Drug Abuse

Objectives: Oral fluid offers an easy and non-invasive method for on-site drug testing; however, on-site devices have not yet met the sensitivity, specificity, and efficiency criteria of 80% proposed by the DRUID project for detection of Δ^9 -tetrahydrocannabinol (THC) in oral fluid. We present performance characteristics and windows of detection of cannabinoids in oral fluid by the on-site Draeger DrugTest® 5000 device after controlled administration of smoked cannabis.

Methods: 10 adult cannabis smokers (9 M, 1 F) provided written informed consent for this Institutional Review Board-approved study, and smoked one 6.8% THC (w/w) cannabis cigarette ad libitum within 10 min. Participants entered the closed research unit from 12 to 18 h prior to dosing, and remained under continuous observation for the entire specimen collection period. Self-reported cannabis intake varied from daily, chronic smokers to a minimum of twice per week cannabis smoking. Oral fluid was collected with the Draeger DrugTest 5000 test cassette and Quantisal™ device (Immunoanalysis) 0.5 h before and 1, 2, 3, 4 and 6 h after dosing; participants had the option of staying on the unit for a second evening with oral fluid collection at 22.5 h. Test cassettes were analyzed immediately and compared to GCMS THC results from oral fluid collected with the Quantisal device and analyzed within 1 day. Time of last detection and sensitivity, specificity, and efficiency were assessed at different cutoffs.

Results: 66-paired oral fluid specimens were analyzed (4 participants did not opt to stay overnight for the optional 22 h specimen collection. Time of last detection ranged from 3 to >22.5 h. Four individuals were positive prior to cannabis administration (despite observed abstinence of at least 12 h) and remained positive at the last collection at 6 or 22.5 h. TN, TP, FN and FP results compared to quantitative Quantisal oral fluid results vary with cutoff applied. At the 5 and 10 ng/mL cutoffs there were 12 and 14 TN results, respectively, 4 (THC from 0-2.9) and 10 FP results (THC from 0-7.4 ng/mL) and 2 (THC 7.8-14.4 ng/mL) and 1 (THC 14.4 ng/mL) FN results.

Performance characteristics at various cutoffs are listed below:

	Draeger Practical Cutoff (10 ng/mL)	Draeger Laboratory Cutoff (5 ng/mL)	SAMHSA Confirmation Cutoff (2 ng/mL)	DRUID Cutoff (1 ng/mL)
Sensitivity (%)	100.0	96.0	90.7	87.7
Specificity (%)	58.3	75.0	75.0	77.8
Efficiency (%)	84.8	90.9	87.9	86.4

Conclusions: The DrugTest 5000 demonstrated good sensitivity and efficiency, and lower specificity. THC GCMS concentrations in false negative specimens were 1.3-7.8 ng/mL. Duration of cannabinoid detection was not conclusively determined due to the 22.5 h monitoring period. Based on prior onsite oral fluid cannabinoid test performance, this monitoring period was projected to be adequate; however, longer monitoring is needed in future studies. These are the best cannabinoid on-site detection data to date, demonstrating that cannabinoid oral fluid on-site testing is feasible, with recent cannabis smoking detected for 3 to greater than 22.5 h.

Key Words: Cannabinoids, Oral Fluid, Draeger DrugTest

DUID Case Involving “Legal High” Internet Drugs: Mephedrone, MDPV and Phenazepam

Michelle A. Spirk*¹ and Greg L. Bacon²

¹Scientific Analysis Bureau, Arizona Department of Public Safety, Phoenix, Arizona, USA;

²Tempe Police Department, Tempe, Arizona, USA

Objective: The objective of this presentation is to discuss analytical and interpretive challenges encountered in a polypharmacy DUID case containing “Bath Salts” (mephedrone and MDPV), phenazepam (Russian benzodiazepine/not prescribed in US) plus additional CNS-active drugs, and to share the Drug Recognition Expert (DRE) case report and related effects on driving.

Methods: The exponential rise in abuse of “Bath Salts” containing synthetic cathinone derivatives, as designer stimulants, has become a world wide phenomenon. Two of these compounds, mephedrone (4-methylmethcathinone) and MDPV (3,4-methylenedioxypyrovalerone) along with the benzodiazepine depressant drug phenazepam, are present in this case. Limited peer-reviewed publications on the effects and related driving impairment of these emerging drugs exist, thus a DRE case report involving mephedrone/MDPV and phenazepam impaired driving should provide additional useful knowledge.

Results: Driving: a 21 year-old male, nearly side-swiped an officer (in marked patrol car) in a school zone; made a wide-radius turn into a store and parked blocking all traffic. Statements/admissions: took a “benzo”, MDPV and mephedrone; stated “Everything I ingested are licit drugs and are not illegal.” Had (3) vials labeled, mephedrone, MDPV and phenazepam (purchased from internet, labeled “Not for Human Consumption”) and a usable quantity of marijuana. Signs and symptoms: DRE evaluation provided numerous signs and symptoms consistent with CNS stimulant and depressant use. As is common with polypharmacy cases, a dominant drug may be suggested, but dosing, drug-drug interactions, etc. should also be considered and care taken to avoid any over interpretation. DRE opinion: under the influence of CNS stimulants, CNS depressant and cannabis; unable to operate a vehicle safely. Toxicology: ELISA and preliminary qualitative GC/MS results provided in table below. Note, the MDMA/ecstasy result was not anticipated. (Select quantitative analysis of blood is underway; sample size is limiting factor.)

ELISA (Screen):	METH (+)	BENZOS (+)	COC/BE (+)	OPIATES (+)	THC (-)
Blood GC/MS (Qual Confirm):	MDMA (+) 135% x-reactivity	Phenazepam (+) 189% x-reactivity	Results pending	Results pending	(Synthetic CN tests pending)
	Mephedrone (+) 5% x-reactivity				
	MDPV (indicated) unk x-reactivity				
Solid Dose Drugs	Mephedrone (+) MDPV (+)	Phenazepam (+)			

Conclusions: “Legal High” drugs, including “Bath Salts”, are readily available via the internet. They are associated with significant detrimental effects on the CNS, including diminished divided attention and related inability to safely operate a motor vehicle. Consideration of these emerging drugs in terms of routine drug screen detection, method validation investments, and a strategy for processing these suspected cases is advisable. This polypharmacy case and DRE evaluation provide insight into both the analytical and interpretive issues associated with “Legal High” drugs in routine impaired driving cases.

Key Words: Mephedrone / MDPV, Bath Salts, DUID

The Role of Legal Drugs in Serious Crashes

Olaf H. Drummer

Forensic Scientific Services, Victorian Institute of Forensic Medicine and Department of Forensic Medicine, Monash University, 57-83 Kavanagh Street, Southbank 3006, Australia

There has been a focus on the increased crash risk associated with use of illicit drugs but there is relatively little data on the contribution of psychoactive prescribed drugs in drivers.

Coroner's office records of all driver fatalities from January 2000 to December 2006 were examined and drivers were assessed for their contribution to the crash to determine the involvement of psychoactive prescription medications on crash risk in fatally-injured drivers in Victoria, Australia, as previously validated [1].

Drugs of any type were found in 29.8% of the study group and alcohol (≥ 0.05 gram/100 mL) was found in 29.5%. The most common drugs detected that are legally available by prescription were opioids (6.0%) (largely morphine, codeine, methadone), benzodiazepines (5.6%), anti-depressants (5.5%) and anti-convulsants (0.9%). As expected, the prevalence of these prescription drugs favored the older driver (≥ 60 years), while the younger driver (≤ 25 years) was more likely to consume illicit drugs such as amphetamines and cannabis. The crash risk of drivers taking common opioids, benzodiazepines, or anti-depressants (including the serotonin reuptake inhibitors), for whom sufficient numbers were available, were not significantly over-represented compared to the drug-free control group; however, crash risk was elevated for drivers using cannabis and amphetamines. These data show that drivers using prescribed medicinal drugs do not show significant crash risk, even if drugs are potentially impairing. However, when used in combination with other impairing drugs, crash risk was significantly increased.

The crash risk of drivers using benzodiazepines was lower than for cannabis and amphetamines, but there is no evidence that the opioid analgesics and antidepressants contribute to serious crashes despite their relatively high prevalence in drivers. The presentation will review the epidemiological evidence for an involvement of prescribed psychoactive drugs on road trauma.

1. O.H. Drummer, J. Gerostamoulos, H. Batziris, M. Chu, J. Caplehorn, M.D. Robertson, and P. Swann, The involvement of drugs in drivers of motor vehicles killed in Australian road traffic crashes. *Accident Analysis & Prevention*. 36 (2004) 239-248.

Key Words: Crash, Fatally-Injured Drivers, Psychoactive Medications

A Model Drugged Driving Law**Marty Conboy**

Omaha, NE, USA

Drug impaired driving (DUID) is as significant a problem as alcohol-impaired driving. Unfortunately, the United States has no national legal standards for defining the crime. The National Partnership on Alcohol Misuse and Crime (NPAMC) and the Institute for Behavior and Health (IBH) convened a committee of nationally recognized law enforcement officers, prosecutors and toxicologists to develop a model Driving Under the Influence (DUI) law. The model incorporates best practices from around the United States, including DUID provisions for prescription medications and illegal drugs. The groups began releasing portions of the model in December 2010. They are presenting the model to stakeholders throughout the country and soliciting input for a final draft which will serve as the foundation for a legislative push in 2011. The presenter will provide a brief overview of current laws, present the model DUID provisions (provided below) and discuss the preliminary feedback.

Section _____

Driving under the influence; definition and penalties

(1) A person is guilty of the offense of driving under the influence and is subject to punishment as provided in subsection (2) if the person is driving or in actual physical control of a vehicle anywhere within this state and:

- The person is under the influence of alcoholic beverages, a chemical or controlled substance as defined in s. _____ any other impairing substance or any combination of two or more of these substances while impaired to the slightest degree; or
- There is any amount of a Schedule 1 chemical or controlled substance as defined in s. _____¹ or one of its metabolites or analogs in the person's blood, saliva, urine, or any other bodily fluid; or
- There is any amount of a Schedule 2, 3 or 4 chemical or controlled substance as defined in s. _____ or one of its metabolites or analogs in the person's blood, saliva, urine or any other bodily fluid. The fact that a person charged with violating this provision consumed the drug pursuant to a prescription issued by a licensed health professional authorized to prescribe it and injected, ingested, or inhaled the controlled substance in accordance with the health professional's directions shall constitute an absolute affirmative defense against any charge of violating this provision related to that particular drug, but no other substance and not any other provision under subsection 1.
- With the exception of (1)(e), the fact that any person charged with violating this subsection is or was legally entitled to consume alcohol or to use a controlled substance, medication, drug or other impairing substance, shall not constitute a defense against any charge of violating subsection 1.

NOTE:

1. Pursuant to 21 USC Sec. 812, Schedule 1 drugs or substances have a "high level of abuse" and "no currently accepted medical use in treatment in the United States."

Key Words: Model Law, Drugged Driving (DUID), Per Se Drugged Driving

Forensic Toxicological Investigations Concerning Motor Vehicle Drivers with a Suspended License: a Retrospective Five Year Review

Antonina Argo^{*2}, Elisabetta Bertol¹, Francesco Mari¹, Viola Bartolini¹, and Francesco Paolo Busardò²

¹Division of Forensic Toxicology, University of Florence, Italy. ² Division of Legal Medicine, University of Palermo, Italy.

Objectives: The authors performed a retrospective study investigating all specimens examined by the Forensic Toxicology Laboratory of the Institute of Forensic Medicine of Florence, Italy from October 2005 to March 2010 from subjects with suspended driver's licenses for criminal offences related to alcohol, drugs or psychoactive substances. The primary objective has been to analyze data about the use of drugs to assess the relative frequency of positivity for different classes of drugs.

Materials and Methods: From October 2005 to March 2010, we evaluated 4115 people who had suspended driver's licenses. This population was predominantly male (89.6%), aged between 18 and 84 years. In all cases, urine and/or hair were used for the detection of drugs and their metabolites. A complete screening test for opiates, cannabinoids, cocaine, amphetamines and amphetamine derivatives, methadone and buprenorphine was carried out with the Enzyme Multiplied-Immunoassay Technique (EMIT) and confirmed by extraction and subsequent identification by gas chromatography/mass spectrometry (GC/MS).

Results: Of all hair and urine samples analyzed, only 5% tested positive. In particular, this study demonstrated a remarkable incidence of cocaine use (60.6% of positive samples) in the population, which was the most recognized substance, either in people undergoing investigation by the Local Medical Committee (LMC) for conditions related to drug use or in cases of driving license suspension related to the abuse of alcohol while driving. Cannabis was found in 3.1% of the cocaine-positive samples and in 22% of all positive samples. Opiates were found in 6.3% of all cases (many other substances were identified within the opiate-positive samples). One subject tested positive for methadone, one for buprenorphine, and 8 subjects' samples were positive for benzodiazepines.

Conclusion: Our study shows that more than 5% of all people examined with suspended drivers licenses had biological specimens positive for drugs. The data demonstrate a widespread use of cocaine among this population, which was found in more than 60% of all positive samples. Furthermore, the high positive rate of drugs found not only in people with histories of drug abuse, but also, in a class of people under investigation for criminal offences unrelated to drug use in this investigation, confirms the spreading drug abuse phenomenon in the general population, consistent with epidemiological and case studies reported in recent literature.

Key Words: Driving Under the Influence of Drugs (DUID), Methodological Approach, Toxicological Investigation

Alcohol and Drugs among Randomly Selected Drivers

Marc Augsburger*¹, Anna Latino¹, Patrice Mangin¹, Jacques Cornuz², Paul Vaucher¹, Hicham Kharbouche¹, Frank Sporkert¹, Nicolas Donze³, Bernard Favrat¹.

¹University Centre of Legal Medicine, Lausanne-Geneva, Switzerland; ²Department of Ambulatory Care and Community Medicine, University of Lausanne, Switzerland; ³Central Institute, Valais Hospital, Sion, Switzerland

Objectives: The major aim of this study was to evaluate the number of drivers positive for drugs and/or ethanol among a randomly selected population.

Materials and Methods: A total of 1300 drivers were randomly selected at 27 different locations in Western Switzerland from October 2006 to April 2008. Drivers were tested for alcohol with a breathalyzer. A blood sample was taken if the result was equal or higher than the equivalent of a blood alcohol concentration of 0.8 g/kg. According to the Swiss Road traffic law, if police officers suspected drug consumption, samples of urine and blood were obtained and analysed. If police officers did not suspect alcohol or drug consumption, consent for taking a sample of saliva (Salivette[®]) was requested. Blood and saliva were analyzed for ethanol by head-space gas chromatography coupled with a FID detector. After two elutions from the Salivette[®] using acetonitrile:methanol (1:1, V/V), the saliva samples were screened for a total of 108 drugs, using SPE purification on Waters HLB and multitarget screening by LC-MS/MS (Shimadzu LC-20 Prominence and AB Sciex 3200 Q trap). Drugs included amphetamines, antidepressants, barbiturates, benzodiazepines, cocaine, cannabinoids, neuroleptics, and opioids.

Results: In the randomly selected populations of drivers, males (70%) predominated over females (30%). The mean age was 41 (range: 16 – 90). Of these drivers, 19 (1.5%) were suspected to be under the influence of drugs and/or alcohol. The presence of ethanol (≥ 0.80 g/kg) (14 cases) and THC (≥ 1.5 μ g/L) (5 cases) confirmed the suspicion of the police officers. Moreover, cocaine (≥ 15 μ g/L) (1 case), amphetamine (≥ 15 μ g/l) (1 case), methadone (1 case) and fluoxetine (1 case) were detected in blood samples of drivers not suspected by the police officers. From the 1281 drivers not suspected to be under the influence of drugs or alcohol, 1048 saliva samples were collected, and 1015 saliva screenings were performed. For 878 drivers (87%), no psychoactive substance was detected in saliva. Among the 1015 saliva samples tested, illicit drugs were detected in 38 cases (3.7%) and prescription or over the counter drugs with driving performance impairing potential in 97 cases (9.6%). Ethanol was found in 35 saliva samples (3.4%). Also, 26 drivers (2.6%) were positive for more than one psychoactive drug. More specifically, 34 drivers (3.3%) were positive for antidepressants, 30 drivers (3.0%) for cocaine, 29 drivers (2.9%) for benzodiazepines, 16 drivers (1.6%) for opioids, 13 drivers (1.3%) for neuroleptics, 6 drivers (0.6%) for cannabinoids, and 5 drivers (0.5%) for other substances. Illicit drugs and ethanol were respectively 2.2 and 1.9 times more present among male drivers than among female drivers.

Conclusion: Approximately 15% of a population of randomly selected drivers were positive for ethanol or other drugs that can affect driving performance and 1.4% of the drivers had a blood alcohol concentration higher than 0.80 g/kg (legal limit for a serious offence).

Key Words: DUID, Drugs, Ethanol

Isomers of Fluoroamphetamines (FAs) Detected in Forensic Cases in Denmark

Sys Stybe Johansen* and Tina Maria Hansen.

Section of Forensic Chemistry, Department of Forensic Medicine, Faculty of Health Sciences, University of Copenhagen, Copenhagen OE, Denmark.

A study was performed on the detection, separation and quantification of isomers from the new designer drugs named fluoroamphetamines (FAs) in Danish forensic cases. The drugs were detected in whole blood extracts by UPLC-TOF-MS and thereafter verified and quantified by UPLC-MS/MS. The quantitative method involved liquid-liquid extraction of FAs from whole blood, evaporation of organic solvent, and reconstitution with a mobile phase mixture. Identification of the FAs was achieved by the retention time, multiple reaction monitoring (MRM) traces [154 > 109; 154>137], and ion ratios of the two transitions. The retention time and ratios were 1.92 min and 1.1 for 4-FA and 1.77 min and 1.7 for 2-FA, respectively. For both FAs, LOQ was 0.002 mg/kg with linear ranges from 0.002 to 1.0 mg/kg whole blood. Since 2008, ten forensic investigations, mainly driving under the influence of drugs (DUID) cases, involved 4-FA with whole blood concentrations ranging from 0.009 mg/kg to 0.58 mg/kg. One autopsy case involved 4-FA; however, it was determined to be a combined intoxication. In 2010, another isomer, 2-fluoroamphetamine (2-FA), was discovered in forensic cases. This isomer was detected by the same UPLC/MS/MS method with MRM transitions similar to the para-isomer (4-FA); however, the ortho-isomer (2-FA) was specifically identified due to its different retention time and ion ratio. Until now, three DUID cases involved 2-FA. The whole blood concentrations of 2-FA were 0.041, 0.071 and 0.028 mg/kg, respectively. These ten cases of 4-FA and three cases with 2-FA also contained amphetamine, but no correlation was observed between the amount of FA and that of amphetamine. To our knowledge, this study confirmed 2-FA in blood from DUID cases for the first time, and provides typical blood concentrations of FAs in forensic DUID.

Key Words: Fluoroamphetamines, Forensic Blood Sample, UPLC-MS/MS

Free and Glucuronide Conjugate Plasma Cannabinoid Pharmacokinetics After Ad Libitum Smoking of a 6.8% Δ^9 -Tetrahydrocannabinol Cigarette

Erin L. Karschner*, David M. Schwoppe, David A. Gorelick and Marilyn A. Huestis
Chemistry and Drug Metabolism, IRP, National Institute on Drug Abuse, NIH, Baltimore, MD.

Supported by the Intramural Research Program, NIH, National Institute on Drug Abuse

Introduction: Δ^9 -Tetrahydrocannabinol (THC) is biotransformed by hepatic cytochrome P450 enzymes to phase I metabolites 11-hydroxy-THC (11-OH-THC) and 11-nor-9-carboxy-THC (THCCOOH). Parent THC and these phase I metabolites form glucuronic acid conjugates to render the structures more hydrophilic, facilitating excretion. We are unaware of any studies that directly measured plasma disposition of THC- and THCCOOH-glucuronides following cannabis smoking. We present pharmacokinetics of THC, THC-glucuronide, 11-OH-THC, THCCOOH, THCCOOH-glucuronide, cannabidiol (CBD) and cannabinol (CBN) after ad libitum smoking of a 6.8% THC (w/w) cannabis cigarette.

Methods: Adult cannabis smokers provided written informed consent to participate in this National Institute on Drug Abuse Institutional Review Board-approved study. Participants entered the closed research unit the evening prior to dosing to ensure that they were not intoxicated at the time of testing. Whole blood specimens were collected at -0.5, 0.25, 0.5, 1, 2, 3, 4, 6, and optionally 22 h post-smoking with plasma separation within 2 h. Plasma was stored in cryotubes at 4°C and analyzed within 24 h. Cannabinoids were extracted with Varian Bond Elut Plexa solid phase extraction columns (Agilent Technologies, Santa Clara, CA), and quantified with a validated LCMSMS method. Limits of quantification were 5 ng/mL for THCCOOH-glucuronide, 0.5 ng/mL for THC-glucuronide and 1 ng/mL for THC, 11-OH-THC, THCCOOH, CBD and CBN.

Results: 10 cannabis smokers (9 males, 1 female) participated, reporting last smoking 1-4 days earlier. Median baseline THC, 11-OH-THC, THCCOOH and THCCOOH-glucuronide concentrations were 1.6 ng/mL (range: not detected [ND]-7.3), 0.0 (range: ND-2.3), 16.6 ng/mL (range: 8.2-100.0) and 83.4 ng/mL (range: 46.2-446.5), respectively, with no detectable CBD, CBN or THC-glucuronide. Some participants were daily cannabis smokers and others occasional smokers. Baseline concentrations reflect this variability and also, time of last cannabis smoking. Following ad libitum smoking, detection rates at 0.25 h (n=9) were 77.8, 88.9 and 66.7% for CBD, CBN and THC-glucuronide, respectively, decreasing to 60.0% for CBD and CBN and increasing to 80.0% for THC-glucuronide at 0.5 h. Detection rates further decreased at 1 h to 10.0, 30.0 and 50.0%, respectively, with no measurable CBD and CBN thereafter. Peak plasma concentrations ranged from 18.2-107.0 ng/mL THC, ND-2.3 ng/mL THC-glucuronide, 4.0-16.3 ng/mL 11-OH-THC, 26.7-110.0 ng/mL THCCOOH, 87.9-463.5 ng/mL THCCOOH-glucuronide, ND-3.4 ng/mL CBD and ND-4.7 ng/mL CBN. While 9 participants had THC \leq 4.5 ng/mL 6 h post-smoking, 1 participant with 7.3 ng/mL at baseline had 9.2 ng/mL THC 6 h post-smoking, and 6.3 ng/mL at 22 h, immediately prior to discharge. This participant reported smoking cannabis 3 days earlier and had smoked approximately 6 joints/day for an extended period, hence the longer window of THC detection.

Conclusion: These are the first directly measured authentic human plasma cannabinoid glucuronide data with simultaneous THC, 11-OH-THC, THCCOOH, CBD and CBN concentrations. CBD, CBN and THC-glucuronide may be indicators of recent cannabis exposure, as they were not detected in any baseline specimen and were absent from plasma 2 h post-smoking. These data will influence future cannabinoid interpretation in forensic investigations.

Key Words: Cannabinoid Glucuronides, Plasma, LCMSMS

Status Update for ForensicDB: A Web-Accessible Spectral Database for Shared Utilization by Forensic Laboratories

Jeri D. Ropero-Miller¹, Peter R. Stout¹, **Katherine Moore**^{2*}, Robert Steiner³, Michelle Peace², John M. Mitchell¹, and Michael R. Baylor¹;

¹RTI International's Center for Forensic Sciences; ²Virginia Commonwealth University; ³Virginia Department of Forensic Sciences (VDFS)

Introduction: The use of cheminformatic databases in the forensic setting has long been established and used to aid in the identification of unknown samples. Many of these databases only include one spectral method, usually EI-MS, and may require a purchase fee or software download. Laboratories not purchasing an available database create their own in-house libraries that are discipline specific with limited to no shared utilization across laboratories. ForensicDB is a community driven, peer-reviewed, and free Web-accessible database that incorporates nominal mass, accurate mass, FTIR, NMR, and chromatographic data. The database also includes newer instrumentation such as Direct Analysis in Real Time (DART) coupled to an accurate time-of-flight mass analyzer. Other than intra-laboratory database creation, there are no public databases that incorporate DART spectra. Spectral data within ForensicDB is continually updated with new drugs of interest to the forensic community without users waiting to purchase or upload a software upgrade. The forensic field is currently in need of the analysis and identification of synthetic cannabinoids and Spice material. ForensicDB is a vital resource for the community in contributing spectral data and searching new emerging recreational compounds.

Methods: Users upload spectra through a Web portal to an editorial review board where selected, external 'collaborator reviewers' evaluate the spectra based on established criteria. RTI staff, as the 'database curator', also review the data and the reviewers' recommendations on whether the spectra should be accepted, rejected, or accepted with revisions. If all criteria are met, spectra are approved and moved into the cheminformatic database for public accessibility. Otherwise, spectra are either rejected or the contributing user may be contacted to determine if better spectra can be submitted. This multi-step, interactive forensic practitioner review process with established criteria of acceptance will help maintain the validity and reliability of the spectra. Inclusion of DART spectra into the database required spectral evaluation and comparison by RTI and Virginia Department of Forensic Science (VDFS). A collection of reference drug standards at RTI were used to evaluate the inter-laboratory reproducibility using the same instrumental parameters as VDFS. Additionally, other commonly changed DART parameters were evaluated to determine their effect on database searching efficiency.

Results: ForensicDB currently includes 1,025 accurate mass records contributed by VDFS and RTI. It also includes 2,096 nominal mass records previously housed in the American Academy of Forensic Science MS database. RTI has added 26 Spice products collected using SPME-HS-GC/MS and DART-AccuTOFTM. There are about 400 synthetic cannabinoids collected using DART-AccuTOFTM, a subset containing the most commonly abused drugs were collected using FTIR and an ESI-LC-MSMS system containing a QTOF. The database proved efficient in searching DART spectra collected at different laboratories and under different instrumental parameters.

Conclusion: ForensicDB provides a standardized collection of reference spectra that can be used to promote new techniques, like the DART-AccuTOFTM and allows public access to spectra of newly emerged compounds. It is important for the community to participate in the submission of spectral data and provide feedback on its searching ability.

Key Words: Cheminformatics, DART-AccuTOFTM, Database

Determination of Gamma-Hydroxybutyric Acid in Dried Blood Spots with “On Spot” Derivatization and GC-MS: Method Development, Validation and Application

Ann-Sofie Ingels¹, Peter De Paepe¹, Kurt Anseeuw², Diederik Van Sassenbroeck³, Hugo Neels⁴, Willy Lambert¹, and Christophe Stove¹

¹Ghent University, Ghent, Belgium; ²ZNA Stuivenberg Hospital, Antwerp, Belgium; ³Maria Middelaes Hospital, Ghent, Belgium; ⁴Antwerp University, Antwerp, Belgium

Objectives: Gamma-hydroxybutyric acid (GHB) or liquid XTC is popular as a club drug and appears occasionally in drug facilitated sexual assaults; therefore, its determination in biological samples is an important issue in toxicology. Given its rapid metabolism, its endogenous presence and the possibility of ex vivo formation, proving GHB misuse remains an analytical challenge. As the dried blood spot (DBS) sampling technique may facilitate blood sample collection, a GC-MS method with “on spot” derivatization was developed and validated. Applicability was demonstrated by collecting and subsequently analyzing DBS from patients presenting with a suspected GHB-intoxication at the emergency department.

Methods: A 6-mm disc was punched out from the DBS, obtained by applying the drop of blood directly onto a Whatman 903 filter paper and drying for a minimum of 2 h at room temperature (RT). After applying GHB-d6 (5 µL of a 25 µg/mL solution in methanol), “on spot” derivatization took place by adding a mixture of trifluoroacetic acid anhydride and heptafluorobutanol (50 µL, 2:1 by vol.), and by heating the sample for 10 min at 60°C. After drying under nitrogen at 25°C and dissolving the dried sample in 100 µL of ethylacetate, the sample was sonicated (2 min) and centrifuged (5 min at 3000 rpm). One µL of the derivatized extract was injected onto the GC-MS, using electron impact and selected ion monitoring (m/z 155, 183, 227 and 242 for derivatized GHB). Punching out a disc requires the investigation of the impact of additional parameters such as the influence of the volume spotted, of the punch localisation and of the hematocrit (Ht). Method validation included the evaluation of linearity, precision, accuracy, sensitivity, dilution integrity, selectivity and stability.

Results: The best blood volume spotted was between 20 and 35 µL, regardless of the Ht of the blood sample. Furthermore, a homogenous distribution of GHB in DBS was demonstrated. The 6-point calibration curve ranged from 2 to 100 µg/mL with a limit of detection of 1 µg/mL. QC samples (2, 10 and 100 µg/mL) were prepared separately in whole blood with low (0.38), intermediate (0.45) and high (0.50) Ht. A weighting factor of $1/x^2$ was chosen and overall acceptable precision (%RSD between 3.8 and 14.8) and accuracy (% bias between 1.2 and 12.2) were obtained. GHB appeared to be stable in DBS stored at RT for at least 148 days. Already in 7 cases, suspected GHB-intoxications were successfully confirmed by DBS analysis. The GHB concentration measured ranged from 79 to 169 µg/mL.

Conclusion: A simple GC-EI-MS method using “on spot” derivatization was successfully developed, validated and applied for the determination of GHB in DBS.

Key Words: GHB, DBS, GC-EI-MS

Aminorex Poisoning in Cocaine Abusers?

Steven B. Karch*¹, Francesco Mari², Viola Bartolini² and Elisabetta Bertol²

¹Consultant Pathologist/Toxicologist, Berkeley, California

²Division of Forensic Toxicology, Dept of Anatomy, Histology and Legal Medicine, University of Florence, Italy.

The ability of equines to metabolize levamisole to aminorex was first recognized in 2009. Earlier this year our group found that humans possess the same ability. This is a new discovery of some public health significance. The DEA reports that nearly 70 per cent of the US cocaine supply is adulterated with levamisole, leaving millions of cocaine users at possible risk. The purpose of this presentation is to review the possible harms that may occur as a result of this discovery.

In 1991, the US Food and Drug Administration approved levamisole (under the brand name of Ergamisol) for use as adjuvant therapy to be used with fluorouracil for the treatment of colorectal cancer. It was withdrawn from the US market in 1999 because, like the drug dexfenfluramine that was withdrawn from the market in 1997, an association between levamisole ingestion and the development of agranulocytosis and necrotizing vasculitis became obvious. Reports describing both disorders began to appear in medical journals last year. Use of levamisole-tainted cocaine seems to produce a distinct syndrome, diagnosed by the presence of circulating plasmacytoid lymphocytes, increased bone marrow plasma cells, and mild megakaryocytic hyperplasia. More than half of those who become ill are found to have anti-neutrophil and HLA-B27+antibodies.

It is not known how completely the body converts levamisole to aminorex, but if the rate of conversion is significant, millions of cocaine abusers are also at risk of developing pulmonary hypertension (PAH). Aminorex is a substrate for serotonin (5HT) transporters (SERT) and is, therefore, an indirect 5HT agonist. 5HT is synthesized in pulmonary artery endothelial cells by the enzyme tryptophan hydroxylase 1 (TPH1). 5HT then acts at the 5-HT (1B) receptor and SERT to mediate vasoconstriction together with proliferation of pulmonary artery smooth muscle cells. Downstream signaling molecules that play a role in serotonin-induced constriction and proliferation include reactive oxygen species (ROS), Rho-kinase (ROCK) p38 and extracellular signal-regulated kinase (ERK). There is also evidence to suggest that serotonin may interact with the bone morphogenetic receptor type II (BMPRII) to provide a 'second hit' risk factor for PAH.

The purpose of this presentation is to review the possible harms that may occur as a result of this newly discovered levamisole to aminorex conversion process in humans.

Key Words: Cocaine, Levamisole, Aminorex, Pulmonary Hypertension

Towards a Model for Residual Hazards from Chemically Contaminated Human Remains**Daniel Noort*** and Jan P. Langenberg

Department of Chemical Toxicology, TNO, P.O. Box 45, 2280 AA Rijswijk, The Netherlands

This project is funded by Defense Threat Reduction Agency (DTRA), USA, under contract HDTRA1-09-C-0025.

The objective of this study was to generate knowledge on the biological and chemical fate of chemical warfare agents (CWAs) on CWA-contaminated human remains. Our aim was to develop a model that could predict the residual hazard relative to the time after death. This would also generate a scientific basis for protocols for the safe handling of contaminated remains, as well as for new decontamination technology. In addition to the relevance for the military field, the generated data are also highly relevant for safe handling of other (possibly) chemically contaminated human remains, e.g., within a forensic context.

In the first stage of the project an experimental set-up was designed, using hairless guinea pigs ($n = 4$) that were exposed percutaneously ($8 \times 1 \mu\text{L}$, equivalent to approximately 10 g/m^2 , a standard surface contamination level) to VX (an organophosphate nerve agent, closely related to organophosphate pesticides) or sulfur mustard, in order to assess the residual hazards of agent remaining on the skin, and in blood and liver after death. The animals were killed 30 min after dosing. Agent levels were determined by means of GC-MS (in case of sulfur mustard and VX on skin) or LC-MS (in case of VX in blood and liver samples). The amount of VX on skin decreased gradually, but VX was still detectable 96 h (last sampling point) after death at levels of $20 - 90 \text{ ug/cm}^2$. For comparison, NATO AEP-58 recommends an allowable residual contamination of 1 ug/cm^2 . VX was detectable in blood ($2-6 \text{ ng/mL}$) for up to 5 h (last possible sampling time point for blood in most cases) and liver (highly variable; up to $7 \mu\text{g/g}$ liver) for up to 96 h, and levels were relatively constant over time. With regard to percutaneous studies with sulfur mustard (a strong alkylating and vesicant agent), this chemical proved to be much less persistent on skin than VX, with levels of $10 - 140 \mu\text{g/cm}^2$ observed until 30 min after application of the agent. In blood, intact sulfur mustard could be detected for up to 23 h, with levels gradually decreasing (from 10 to 3 ng/mL). In liver, intact sulfur mustard could be detected for up to 48 h (but not in all animals) at levels ranging from 175 to 10 ng/g . In general, sulfur mustard levels in liver were much lower (depending on sampling time) than VX levels, probably reflecting the much higher intrinsic reactivity of sulfur mustard. Vapor hazard of sulfur mustard by off-gassing was most pronounced in the first 24 h after death, with amounts ranging from a total of $500 \mu\text{g}$ sampled between $-0.5 - 1 \text{ h}$ after death, to a total of $5 \mu\text{g}$ sampled between 72 -96 h after death. For both VX and sulfur mustard, a number of (potentially) toxic metabolites (including the notorious desethyl VX and sulfur mustard sulfoxide) could be detected, but amounts were low (e.g. for desethyl VX: 0.2 ng/mL blood) relative to the parent agent.

In conclusion, these results are valuable data for the development of a model to predict the residual hazard after death. In future experiments, methods for proper decontamination of contaminated remains will also be addressed

Key Words: Postmortem Toxicology, Chemical Warfare Agents, Chemical Contamination

UPLC-MS/TOF: An Easy and Fast Screening Method for Clinical Toxicology

Birgit Henschel*, Alexander von Meyer, and Jürgen Hallbach
Munich Clinic, Munich, Germany

Objectives: To establish screening methods in clinical toxicology utilizing HPLC-DAD, GC-MS and HPLC-MS/MS. These methods require specific libraries for the identification of unknown substances. Using Ultra-Performance Liquid Chromatography (UPLC) coupled with time of flight mass spectrometry (TOF) and lock mass correction allows for measurement of low and medium molecular weight substances (< 3000 Da) with a mass error not exceeding a few mDa. The measurement of the exact mass of an unknown substance leads directly to its atomic composition and its empirical formula. In addition, the results can be confirmed by comparing them with the retention time and mass spectra of pure standards analyzed in the same way.

Methods: Urine or serum samples were extracted with ToxiTubes A[®] (Varian). The organic phase was dried and reconstituted in methanol/water (1:2) and 5 µl was injected onto a 2.1 x 100 mm, 1.8 µm Acquity UPLC-HSS T3 column. The UPLC method (linear gradient 10% to 90% methanol) was optimized for a broad spectrum of clinically relevant substances. For detection of analytes, a LCT Premier XE (Waters) was used in order to accumulate data with and without in-source fragmentation. To identify unknown substances in patient samples, first mass traces with 5 mDa tolerance were extracted and a low area threshold for peak detection was established. Next, the extracted mass, retention time, and mass of a selected fragment were compared with a database (compound name, RT, exact mass, one fragment).

Results: All hits were further analyzed by full spectra comparison. The pure spectra of more than 450 substances were established and will continue to be extended. Samples from patients were compared with GC-MS showing 90% accordance of results. In a few samples additional substances, for example low dosed fentanyl, could be detected. Therefore, UPLC-MS/TOF technology is an alternative screening procedure.

Conclusions: Frequently in clinical toxicology, there is evidence of some suspected substances or metabolites that are not included in the database. In such cases, a big advantage of TOF-technology is that all ions detected in the flight tube are registered and stored as raw data. Knowing the sum formula and therefore the exact mass of such substances, the raw data of the actual or a stored chromatogram can be reanalyzed using a mass filter which extracts the molecular mass of the expected substance(s). This screening method is fast and data can easily be interpreted offering the opportunity to check samples for analytes where no pure reference standards are available. In conclusion, UPLC-MS/TOF is an excellent alternative screening procedure to HPLC-DAD, GC-MS and HPLC-MS/MS and can be used as a complementary screening method in clinical toxicology laboratories.

Key Words: UPLC-MS/TOF, Clinical Toxicology, Screening Method

The Clinical Utility of a Comprehensive Time-of-Flight LC-MS Serum Drug of Abuse Panel in Emergency Intoxication Cases

Roy RL Gerona^{*1}, Craig Smollin² and Alan HB Wu¹

¹Department of Laboratory Medicine, San Francisco General Hospital/ University of California, San Francisco, San Francisco, CA

²California Poison Control System- San Francisco Division, University of California, San Francisco, San Francisco, CA

Background: More than 100,000 annual emergency department (ED) visits are linked to intoxication from drugs of abuse. Drug intoxication ranks high in the differential diagnosis of ED patients with mentally altered status. Ruling in the abuse of a specific drug in these patients in a timely manner will not only save resources; more importantly, it will insure the delivery of the appropriate management regimen. We have taken advantage of advances in the mass accuracy, resolution, and speed of liquid chromatography-time-of-flight mass spectrometry (TOF LC-MS) to develop a semi-quantitative serum drug of abuse panel with a turnaround time that is relevant to ED testing.

Methods: We set up a rapid, semi-quantitative TOF LC-MS assay that can detect 220 drugs of abuse in patient serum. The panel's drug coverage include commonly abused drugs (and their pharmacologically active metabolites) such as amphetamines (41), opioids (28), benzodiazepines (32), barbiturates (16), stimulants (9) and psychotropic alkaloids (10), and drug classes that may potentially be abused such as antidepressants (24), sedatives/hypnotics (10), anesthetics (10), antihistamines (14), analgesics (13) and muscle relaxants (13). The panel was developed using TOF LC-MS (Agilent LC 1260, TOF MS 6230) with electrospray ionization in positive and negative modes. Serum samples (100-250 μ L) from ED patients suspected of drug intoxication were analyzed after protein precipitation. Separation of the analytes was achieved by gradient elution using Eclipse Extend Plus C18 (Agilent) column. The raw data obtained from each sample run was analyzed using MassHunter Qualitative and Quantitative Analysis (Agilent) to determine what and how much analyte(s) is present in the patient's serum.

Results: The overall analytical turnaround time for each sample is 1-2h, of which 24 minutes is accounted for by two TOF LC-MS runs. The analytes in the panel have limits of detection of 0.5-50 ng/mL, linear concentration range of 200-500 ng/mL, %CV values of 2-10% and 6-20% for within run and between run precision, respectively, and % recoveries of 80-115%. Of the 55 emergency intoxication cases referred by the California Poison Control Center in San Francisco, 29 cases screened positive for drugs included in the panel. The relative serum levels of drugs in these patients were also reported facilitating delivery of appropriate management advice to the attending medical team of some cases in real time. Furthermore, with the unique ability of TOF LC-MS to facilitate untargeted drug screening, we were also able to report strong formula matches to drugs outside the panel that can potentially account for a patient's intoxication in some cases. The panel's utility in ruling-in drug intoxication among ED patients with mentally altered status in real time and its impact on clinical management is currently being tested.

Conclusions: With its fast turnaround time and wide breadth of drug coverage, the serum TOF LC-MS drug of abuse panel can be extremely useful in ruling-in drug abuse in emergency intoxication cases.

Key Words: Drug of Abuse Testing, Liquid Chromatography-Time-of-Flight Mass Spectrometry, Emergency Toxicology Screening

Findings of MDMA and MDA in Hair, Blood and Urine by LC-ESI-MS/MS: Report of 11 Drug Facilitated Crime Cases with Anterograde Amnesia

Marc Deveaux^{1*}, Guillaume Hoizey¹, Marjorie Chèze¹, Aurélie Muckenstrum¹, Anne-Laure Péliissier-Alicot² and Gilbert Pépin¹
¹Laboratoire Toxlab, Paris, France; ²Médecine Légale, Faculté de Médecine, Marseille, France

Objectives: We present an application of a previously published method by liquid chromatography-triple stage quadrupole-tandem mass spectrometry with electrospray probe (LC-ESI-MS/MS) for the determination of MDMA and MDA in hair, urine and blood. We report eleven cases of drug facilitated crimes (DFC) with anterograde amnesia where the perpetrator was alleged to have given MDMA to the victim.

Materials and Methods: Urine and blood collected within 2 to 44 hours after the crime were extracted with ToxiTubeA®; deuterated amphetamines (amphetamine (A), methamphetamine (MA), MDA, MDMA, MDEA and MBDB) were added as internal standards. Hair was collected within 4-6 months. To 20 mg of decontaminated by dichloromethane and finely cut hair, the same deuterated i.s. were added. Hair specimens were digested with NaOH at 80°C for 15 min. Extraction was performed with hexane/ethyl acetate (2/1). The organic layer was evaporated to dryness; the residues were reconstituted in methanol and injected into a LC- MS/MS TSQ Quantum Ultra (ThermoFisher Scientific). Separation was achieved on a C₁₈-column (Uptisphere ODB 150 x 2 mm, 5 µm) at 30°C. Mobile phase (formate buffer 2 mM pH 3/ ACN) was delivered in gradient mode for a total run time of 20 min. The detection was performed in positive ESI and in SRM mode and allowed for the simultaneous detection of A, MA, MDA, MDMA, MDEA and MBDB. To each [M+H]⁺ ion, four product ions were acquired at a scan time of 0.1 s with a width of 1.0 a.m.u. For MDMA and MDA, detection limits were 0.1 ng/mL in blood and urine, and 5 pg/mg in hair.

Results: Victims were 2 males and 9 females (17-26 year-old). In 7 cases, moderate amounts of alcohol and cannabis had also been voluntarily consumed.

The results ranges are given in the following table:

	MDMA	MDA
Blood (ng/mL)	0.1 - 475 (n=5)	0.1 – 22 (n=4)
Urine (µg/mL)	1.2 – 90 (n=5)	0.1 – 4 (n=4)
Hair, 2cm-segment corresponding to the period of the DFC (pg/mg)	16 – 2700 (n=8)	16 – 400 (n=7)
Hair, other segments (pg/mg)	not detected (n=8)	not detected (n=8)

Discussion and Conclusion: Even if blood and urine were not always available, segmental hair analysis provided retrospective information very helpful to solve the cases when the victim lodged a complaint several days after the suspected intake of MDMA. Moreover, segmental hair analysis showed the victim's drug abstinence outside the period of the offence.

The symptoms described by the victims were very similar: euphoria and excitation, which are the classical effects of MDMA, but also slight disruption of memory (impairment of the spatial memory) and in one case, a total and massive anterograde amnesia. This kind of amnesia is very rare with MDMA and is perhaps due to the simultaneous ingestion of MDMA and alcohol.

Key Words: Drug Facilitated Crime, MDMA, Segmental Hair Analysis

A New Degradation Product of Olanzapine

Eva Saar*¹, Dimitri Gerostamoulos,^{1,2} Olaf H. Drummer,^{1,2} and Jochen Beyer^{1,2}

¹ Department of Forensic Medicine, Monash University, 57-83 Kavanagh Street, Southbank VIC 3006, Australia; ² Victorian Institute of Forensic Medicine, 57-83 Kavanagh Street, Southbank VIC 3006, Australia

Objectives: The atypical antipsychotic drug olanzapine (OLZ) is not only amongst the most commonly prescribed antipsychotics but is also frequently detected in post-mortem cases. OLZ shows stability problems in stored plasma and blood samples and on the autosampler during analysis, which complicates its detection and quantification. There has been extensive discussion concerning the extent of the degradation and whether or not the addition of ascorbic acid as an antioxidant improves stability. The aim of this study was to determine possible degradation products of OLZ and to ascertain the extent of the degradation under several authentic conditions.

Methods and Materials: Blank blood (500 μ L) was fortified with an OLZ spike solution to obtain a target concentration of 0.2 mg/L and subsequently divided into five 100 μ L aliquots. The blood aliquots were left at 4°C for one week and extracted using a previously published method. The sample extracts were left at room temperature for one week in order to obtain the maximum degradation of OLZ. A Q1 scan, precursor ion scan of m/z 84 and product ion scan of m/z 329 were performed using an ABSciex QTRAP[®] 5500 LC-MS/MS System and an ABSciex TripleTOF[™] 5600. Four sets of samples (A-D) were prepared: set A and B consisted of blood samples fortified with OLZ at a concentration of 0.1mg/L stored at 4°C and the addition of 0.25% ascorbic acid (A) or without the addition of ascorbic acid (B). Set C and D consisted of distilled water fortified with OLZ at a concentration of 0.1mg/L and the addition of 0.25% ascorbic acid (C) or without the addition of ascorbic acid (D). Duplicates of all sets were analysed over two weeks in order to measure the degradation of OLZ and the formation of the degradation product. The Q1 scan revealed an ion m/z 329 containing an additional fragment of m/z 84, whose structure was confirmed as 2-Hydroxymethyl-OLZ (2OHM-OLZ) using precursor ion scan of m/z 84 and a product ion scan of m/z 329 by comparison of the spectra with those of a commercially purchased pure standard of 2OHM-OLZ. The degradation of OLZ in whole blood appeared to be partly inhibited by the addition of ascorbic acid, but after ten days of storage both sample-sets (A, B) showed comparable losses (~95%). The formation of 2OHM-OLZ only appears to take place in water on the autosampler, but not in stored blood samples. Furthermore, the addition of ascorbic acid seemed to inhibit the formation of 2OHM-OLZ in water.

Conclusions: A new degradation product of OLZ in water was identified and can be used to monitor the degradation of OLZ in aqueous solutions. Care must be taken when reconstituting in aqueous solvents (a common practice in LC analysis) in order to best preserve sample integrity.

Key Words: Olanzapine, Stability, Degradation Product

A Case Report of Death Due to Respiratory Depression Following Methadone Ingestion in an Eleven-Month-Old Boy – Accident or Child Abuse?

Gilles Tournel^{1,*}, J. Pollard¹, R. Cornez¹, Y. Delannoy¹, L. Humbert², J.-F. Wiart², D. Allorge², D. Gosset¹, V. Hédouin¹, M. Lhermitte².

¹ Institut de Médecine Légale, CHRU de Lille, France- ² Laboratoire de toxicologie, Centre de Biologie Pathologie – CHRU Lille, France.

Introduction: An 11-month-old boy was discovered dead in his bed in his family's home. Considering the boy's age and the fact that his parents had judicial backgrounds, crime scene investigations were performed. Initially, Sudden Infant Death Syndrome (SIDS) was suspected. The forensic practitioner did not observe any traumatic injury but, subsequently, considering the circumstances of the discovery, an autopsy was performed. The autopsy findings were negative. No organs were injured and, although the cause and manner of death were not established, a traumatic cause of death was definitely excluded. Toxicological and histopathological analyses were subsequently performed on various matrixes including vitreous humour, cardiac blood, urine, bile, gastric content and hair.

Results: The toxicological screening identified the presence of methadone and its metabolite (EDDP) in all tested fluids. The concentrations of methadone and EDDP are shown in the table below and expressed as ng/mL.

Molecules	Cardiac blood	Gastric content	Urine	Bile
Methadone	73	735	1784	490
EDDP	35	104	2104	1695

Considering the unexpected toxicological findings, hair analysis was performed (table below).

	Segment 1 (root)	Segment 2	Segment 3	Segment 4 (end)
Weight (mg), 4 cm	19	16	13	13
Methadone (pg/mg)	900	900	1800	1400
EDDP (pg/mg)	80	610	150	340

Considering these results, a hair sample from the mother (20 cm) was analysed (table below).

	Segment 1 (root)	Segment 2	Segment 3	Segment 4 (end)
Period (months)	m	m-1	m-11 (breastfeeding)	m-17 (pregnancy)
Weight (mg)	27	19	34	38
Methadone (pg/mg)	2800	5100	11700	7700
EDDP (pg/mg)	< 100	2000	500	100

Discussion: The observed blood concentration of methadone (73 ng/mL) corresponds to a therapeutic concentration in adults undergoing opioid substitution treatment, but is regarded as a toxic concentration in untreated subjects. Considering the age of the child, acute methadone poisoning was considered to be the cause of death in this particular case. Methadone poisoning is rare in infants and, in most cases, of accidental origin. As a few cases of intentional poisoning by parents have been described, child abuse was suspected. Hair concentrations of 2450 to 78100 pg/mg and 980 to 7760 pg/mg for methadone and EDDP, respectively, have been reported previously in chronic users of methadone. The observed concentrations in this child's hair were low and relatively homogeneous in all segments tested. Consequently, interpretation was difficult and external contamination by the addicted parents could be ruled out. Furthermore, current methodologies in hair analysis to determine the origin of exposure (chronic or acute) remain controversial. The presence of EDDP in the child's hair could be explained by maternal-fetal passage during pregnancy and during breastfeeding. This hypothesis is supported by the presence of high concentrations of methadone and EDDP in the mother's hair, especially in segments corresponding to the periods of pregnancy and breastfeeding.

Conclusion: In infant intoxication cases, as reported here, a multidisciplinary approach is necessary between the forensic pathologist, pediatrician, toxicologist and judiciary to determine accurately the cause and manner of death, and, specifically, the nature of the poisoning (acute or chronic).

Key Words: Methadone, Child Abuse, Hair, Multidisciplinary

An Epidemic of Fatal and Non-fatal Para-methoxymethamphetamine (PMMA) Intoxications in Norway

Merete Vevelstad^{a,*}, Elisabeth Leere Øiestad^a, Gerrit Middelkoop^a, Inger Hasvold^a, Jørg Mørland^{a,b}, Peer Lilleng^c, Gerd Jorunn, Møller Delaveris^d, Tormod Eggen^e, Marianne Arnestad^a

^aDivision of Forensic Toxicology and Drug Abuse (DFTDA), Norwegian Institute of Public Health (NIPH), P.O. Box 4404 Nydalen, N-0403 Oslo, Norway; ^bUniversity of Oslo, The Medical Faculty, P.O.Box 1078 Blindern, N-0316 Oslo, Norway; ^cSection of Pathology, The Gade Institute, University of Bergen and Haukeland University Hospital, N-5021 Bergen, Norway; ^dInstitute of Forensic Medicine, University of Oslo, N-0424 Oslo, Norway; ^eDepartment of Pathology, University Hospital of North Norway, N-9038 Tromsø

Objective: We investigated a Norwegian epidemic of fatal and non-fatal intoxications related to PMMA (para-methoxymethamphetamine). This toxic designer drug, known as “Death”, is occasionally found in street drugs offered as “ecstasy” or “amphetamine”. We evaluated the cause of death, whether poly-drug use had any major impact on PMMA toxicity, and compared the PMMA blood concentrations in fatal and non-fatal cases related to PMMA.

Materials and Methods: During a 6 month period (July 2010-January 2011), we observed 12 fatal intoxications and 22 non-fatal cases related to PMMA in Norway (4.8 mill inhabitants). The fatalities were subjected to forensic autopsy with collection of femoral venous blood and urine, which were sent for analysis to the Division of Forensic Toxicology and Drug Abuse, National Institute of Public Health. The non-fatal cases represented suspected criminal offences such as drug use or driving under the influence of drugs/alcohol (DUI). Sample preparation was performed by protein precipitation with acetonitrile followed by dilution (1:1) of the supernatant with water. Amphetamine-d11 was used as internal standard, and screening and confirmation of PMMA and PMA were performed by UPLC-MS/MS.

Results: The median age of fatalities was 30 years (range 15-50) with 67% males; in non-fatal cases 27 years (20-47) with 86% males. In the 12 fatalities, the median PMMA blood concentration was 1.92 mg/L (range 0.17-3.30), which was within the reported lethal range of 0.6-3.1 mg/L in peripheral blood and 1.2-15.8 mg/L in heart blood. For PMA, the reported lethal range was 0.2-5.9 mg/L. In the 22 non-fatal cases, the median PMMA concentration was 0.07 mg/L (range 0.01-0.65). Poly-drug use was frequent both in fatal and non-fatal cases. The PMA concentrations ranging from 0.00 to 0.26 mg/L in both groups likely represented a PMMA metabolite. Three fatalities were attributed to PMMA only, six to PMMA and other psychostimulant drugs, and three to PMMA and CNS depressant drugs, with median PMMA concentrations of 3.05 mg/L (range 1.58-3.30), 2.56 (1.52-3.23) and 0.52 mg/L (0.17-1.24), respectively. Eight victims were found dead, while death was witnessed in four, with symptoms of acute respiratory distress, hyperthermia, cardiac arrest, convulsions, sudden collapse and/or multiple organ failure.

Conclusion: All fatalities attributed to the ecstasy-substitute PMMA had high PMMA blood concentrations, compared to non-fatal cases. Our sample size was too small to evaluate a possible impact of poly-drug use. A public warning is warranted against use and overdose with illegal “ecstasy” or “speed” drugs.

Key Words: Para-methoxymethamphetamine, PMMA, Fatal Intoxication

A Review of Deaths in Subjects Commencing A Methadone Maintenance Program – A 15 Year Follow Up

Maria Grazia Pricone*¹, Michael McDonough³ & Olaf H. Drummer^{1,2}, Dimitri Gerostamoulos^{1,2}

¹Victorian Institute of Forensic Medicine; ² Department of Forensic Medicine, Monash University, Southbank, Victoria, Australia;

³Addiction Medicine & Toxicology, Western Hospital, Melbourne, Victoria, Australia.

Introduction: Methadone is a synthetic non-opiate narcotic with a long terminal elimination half-life used in the treatment of opiate addiction. In 1990, Drummer et al. (1990) reported that 10 heroin addicts died within days of starting a methadone maintenance program run by general practitioners. Deaths were related to high starting doses and the accumulation of methadone over the first few days of therapy. The other drugs that were detected in these cases were not regarded as capable of causing death by themselves.

Objectives: This report reviews deaths involving methadone over a five year period. The purpose was to identify deaths involving individuals in the early stages of methadone administration (up to 14 days) where the presence of methadone was deemed to be the primary cause of death or contributory to death. Furthermore, the study aimed to explore the circumstances surrounding death in these cases, as well as the prevalence of other drugs.

Materials and Methods: Cases were subject to full autopsy and toxicological examination. Prescribing information was obtained from the regulatory body administering the methadone prescription.

Results: 260 deaths involved methadone over a 5 year period (2001-2006) in Victoria. Of these cases, 52 (20 %; 13 female and 39 males) died within 14 days of commencing a methadone maintenance program with methadone being administered via syrup. The median (mean; range) age was 32 years (31 years; 17-51 years). The median (mean; range) blood methadone concentration was 0.5 mg/L (0.6 mg/L; 0.1-3.0 mg/L). The median (mean; range) starting dose was 35 mg (37 mg; 20 – 100 mg). A number of cases were identified as having too high a starting dose, with 33 % having a dose between 30 – 39 mg and 44 % having a dose of 40 mg or more. Many of these cases had an escalation of dose during the induction period with the median (mean) dose at time of death being 40 mg (48 mg). Ninety-eight percent of cases involved the use of other central nervous system depressants including: opioids, antidepressants, antipsychotics, ethanol with the most common being benzodiazepines (88 % confirmed positive). Only one death occurred when negative for other drugs and alcohol in the induction phase of methadone treatment. Of the 52 deaths that occurred within 14 days of commencing a methadone program, 13 (25 %) of these involved suspected use of heroin/morphine.

Conclusion: These data support the existence of an increased risk in the induction phase of a methadone maintenance program, in particular, with concurrent consumption of central nervous system depressants drugs.

Reference: Drummer OH, Syrjanen M, Opekin K, Cordner S. Deaths of heroin addicts starting on a methadone maintenance programme. *Lancet* 1990;335(8681):108

Key Words: Methadone, Maintenance, Treatment, Overdose and Toxicology

Hug Drug or Thug Drug? The Reincarnation of MDMA in San Francisco Postmortem Cases: Five Years in Review (2006-2010)**Patil Armenian***¹ and Nikolas P. Lemos^{2,3}¹California Poison Control System, San Francisco Division, Division of Clinical Pharmacology, University of California, San Francisco, CA, USA; ²Office of the Chief Medical Examiner, City and County of San Francisco, San Francisco, CA 94103, USA;³Department of Laboratory Medicine, School of Medicine, The University of California, San Francisco, CA 94143, USA

Objectives: 3,4-Methylenedioxymethamphetamine (MDMA, ecstasy) is familiar to clinical and forensic toxicologists as a drug of abuse causing adverse reactions and occasional overdose in the dance club setting. A departure from such accidental deaths to homicide was first reported by the San Francisco Office of the Chief Medical Examiner in 2003. We aim to further characterize MDMA-associated mortality in the City and County of San Francisco.

Methods: A retrospective study was conducted using records from the Office of the Chief Medical Examiner of the City and County of San Francisco from January 1, 2006 to December 31, 2010. Any case with MDMA in blood, urine, or bodily tissue was included in the study sample. Blood and urine screening was accomplished with ELISA, and quantitation by GC-MS. Subjects whose biological specimens contained MDMA were examined for age, sex, race, cause and manner of death, MDMA and 3,4-methylenedioxyamphetamine (MDA) blood concentrations, and presence of other drugs. This information was tabulated on commercially available spreadsheet software for processing and review.

Results: 59 cases met inclusion criteria; 52 (88%) involved males with a median age of 28 years. The majority race was black (34 of 59 cases or 58%), followed by 18 white (31%), 5 Asian (9%) and 2 Hispanic (3%). In 36 of 59 cases (61%), the manner of death was homicide, almost always (94%) due to gunshot wounds (GSW). Among blacks 32 of 34 (94%) deaths were homicides. All black homicide victims with the presence of MDMA died as a result of GSW. Among whites, 3 of 18 (17%) deaths were due to homicide (1 blunt trauma, 1 stabbing, 1 GSW), while 12 of 18 (67%) deaths were accidents and 2 of 18 (11%) were due to suicide. In 5 Asian patients the manner of death was accident in 3, suicide in 1 and natural death in 1. Of the 2 Hispanic patients, the manner of death in 1 was homicide and 1 was accident. Of 59 cases, 9 had MDMA in urine only; no blood or tissue specimens were positive. Liver was used for MDMA quantitation in 1 case, while in 4, quantitation was below detection limits. Mean MDMA blood concentration in the remaining 45 cases was 0.51 mg/L (median: 0.28, range: 0.03-3.6). In the homicide deaths, mean [MDMA] was 0.49 mg/L (median: 0.30, range: 0.03-2.1). 26 cases had MDA in blood, of which 11 had quantitative concentrations with a mean of 0.046 mg/L (median: 0.03, range: 0.01-0.20). Other drugs and xenobiotics were detected in 56 of 59 (95%) cases. 32 co-ingestants were detected in the 17 accidental deaths. 3 homicide cases had no other compounds present in blood or urine. 7 co-ingestants were detected in the other 33 homicide cases. These included methamphetamine and amphetamine (21/33), ethanol (15/33), cocaine and metabolites (14/33), cannabinoids (6/33), piperazines (2/33), promethazine (1) and opiates (1), often in combination. The drug found most commonly in combination with other non-MDMA compounds was ethanol, in 11 homicide cases.

Discussion and Conclusions: Although MDMA is known to play a role in accidental deaths, this study is novel in the detection of MDMA in young black male homicide victims in San Francisco. All of our black homicide victims died as a result of GSW. The study is the first of its kind and clearly supports our previous findings that MDMA is no longer confined to the club or dance setting, but has evolved to different socio-economic strata and more violent street conflicts. This phenomenon currently appears to be localized to the San Francisco Bay area but further research examining the drug's incidence in trauma patients and perpetrators, and additional medical examiner retrospective data collection is needed to better understand and characterize both incidence and causality.

Key Words: MDMA, Homicide, San Francisco

Quantification of Tetrahydrocannabinol in Oral Fluid Collected with the Statsure, Quantisal or Certus device by UPLC-MS/MS

Sarah MR Wille*, Vincent Di Fazio and Nele Samyn

Laboratory of Toxicology, National Institute of Criminalistics and Criminology, Vilvoordsesteenweg 100, Brussels, Belgium

Introduction: Driving under the influence of drugs (DUID) is a worldwide public health problem. About 5-25% of collision-involved drivers test positive for drugs and cannabis is generally the most commonly detected. In Belgium, a 'per se' DUID-law has passed in which the results of an oral fluid on-site test (Drugwipe 5⁺) are confirmed by oral fluid analysis using chromatographic techniques. The required tetrahydrocannabinol (THC) cut-off for this confirmatory oral fluid analysis is 10 ng/mL. Therefore, an ultra performance liquid-chromatographic mass spectrometric (UPLC-MS/MS) method quantifying THC in oral fluid was developed and validated according to international guidelines (Food and Drug Administration, European Medicines Agency). Because the method of oral fluid collection has an influence on THC stability and recovery, and also on the performance of the analytical method, 3 commercial oral fluid collectors [StatSure (Diagnostic Systems), Quantisal (Immunoanalysis) and Certus (Concateno)] were evaluated.

Method: A Xevo-Triple Quadrupole MS (Waters, Manchester) was used. Separation from endogenous compounds was achieved on an ACQUITY UPLC® BEH C₁₈ 2.1mm x 100mm x 1.7µm column using a methanol/ammonium-formate (1 mM) gradient at a flow rate of 0.35 mL/min. Run time of the method was 4 min. MS parameters were established in ESI⁺ mode. Cone voltage and collision energy were optimized to generate specific MRM transitions. Formulas were developed to determine the 'pure oral fluid' THC content by taking the actual collected amount of oral fluid (by weight) and dilution factor of the collector into account. During development, focus was put on 'high-throughput', ease, and minimizing use of organic solvents. THC was extracted using a liquid/liquid extraction (LLE) with 1 mL of hexane and high-recovery extraction vials (Waters, Milford).

Results: A simple and robust method in which 50 samples can be prepared and analysed within 4-5 hours was developed. THC was stable under different storage conditions and no interferences due to metabolites or other cannabinoids were observed. The calibration curve ranged from 5-320 ng/mL THC and was fit to a linear least-squares regression with a weighting factor of 1/x and correlation coefficients ≥ 0.998 . The LLE was reproducible (99-119%; 5-11 RSD, n=6) and concentration independent. Collector recovery ranged from 50 to 70%. While differences in matrix effects were observed due to the collector buffers, the internal standard THC-d3 always compensated. Repeatability and intermediate precision at the quantification limit (LOQ, 5 ng/mL), at low, medium and high concentrations fulfilled the criteria of an RSD < 20% at LOQ, and < 15% at the other concentrations. Bias was $\pm 3\%$ and the measurement uncertainty was $\pm 6\%$.

Conclusion: A fast UPLC-MS/MS method for quantification of THC in oral fluid collected with the Statsure, Quantisal or Certus collector was developed and validated. Special emphasis is put on the effects of the oral fluid collectors on matrix effects and on THC stability and recovery.

Key Words: Tetrahydrocannabinol, Oral Fluid Collection, Matrix Effects

Abuse of Benzodiazepines and/or Zolpidem Proved by Hair Analysis

Sooyeun Lee, Jihyun Kim, Sanghwan In, Hwakyung Choi, Sanghee Woo, **Eunmi Kim*** and Heesun Chung.
National Forensic Service, Seoul, Republic of Korea.

Objectives: Benzodiazepines and zolpidem are controlled in many countries due to their inherent adverse effects including a high degree of tolerance and dependence. Recently, as these drugs are distributed illegally and available through the internet, their abuse is increasing. In the present study, nine legal cases involving benzodiazepines and/or zolpidem were substantiated by hair analysis using a simultaneous analytical method for the detection of 27 benzodiazepines and metabolites and zolpidem in hair by liquid chromatography-tandem mass spectrometry (LC-MS/MS).

Methods: The hair samples were washed with methanol and distilled water, cut and weighed (10-30 mg). Drugs and their metabolites were extracted from hair using methanol. Extracts were filtered and injected on the LC-MS/MS. The analytical column used was a Zorbax Eclipse XDB-C18 (4.6 x 150 mm, 5 µm) maintained at 40°C. A gradient was performed with mobile phase consisting of 2 mM ammonium formate and 0.2% formic acid in water (A) and 2 mM ammonium formate and 0.2% formic acid in acetonitrile (B) at a flow rate of 1000 µL/min. The MS system was operated using electrospray ionization (ESI) in positive mode. The following validation parameters of the method were satisfactory: selectivity, linearity, matrix effect, recovery, process efficiency, intra- and inter-assay precision and accuracy and processed sample stability. The limits of detection (LODs) ranged from 0.005 ng (zolpidem) to 0.5 ng (bromazepam and chlordiazepoxide) and the limit of quantification (LOQ) was 0.25 ng (except for bromazepam and chlordiazepoxide whose LOQ was 0.5 ng).

Results and Conclusions: Six of the nine cases involved drug abuse by medical staff and/or the use of inappropriate prescriptions. Two offenders were illegal drug dealers and one was a known methamphetamine user. Drugs and metabolites found in the hair samples were alprazolam, clonazepam and its metabolite, clonazepam, diazepam and its metabolites, lorazepam, midazolam and zolpidem. Since benzodiazepines and zolpidem are easily obtainable (e.g. by medical staff), the supervision of the persons handling these drugs is recommended.

Key Words: Benzodiazepines, Hair, LC-MS/MS

Cannabinoids in Oral Fluid Following Passive Exposure to Marijuana Smoke

Christine Moore^{1*}, Cynthia Coulter¹, Donald Uges², James Tuyay¹, Susanne van der Linde², Arthur van Leeuwen², Margaux Garnier¹, Jonathan Orbita, Jr.¹

¹Immunoanalysis Corporation, Pomona, CA, USA; ²University Medical Center, Groningen, The Netherlands

Introduction and Objectives: The concentration of tetrahydrocannabinol (THC) and its main metabolite 11-nor-D⁹-tetrahydrocannabinol-9-carboxylic acid (THC-COOH) as well as cannabinol (CBN), and cannabidiol (CBD) were measured in oral fluid following realistic exposure to smoked marijuana in a Dutch coffee-shop. Ten healthy subjects, who were not marijuana smokers, volunteered to spend 3 hours in two different coffee shops in The Netherlands. Oral fluid specimens were collected at different time points up to 12 hours after entering the shop. Our objective was to determine the presence of cannabinoids in oral fluid after realistic passive exposure to marijuana smoke.

Methods: Ten healthy Caucasian individuals, five males, average age of 22.8y; 84kg (185 lbs); height 1.9m (6'2"); BMI 23.3; and five females, average age of 23.8y; weight 62.4kg (137lbs); height 1.71m (5'6"); BMI 21.2 were exposed to marijuana smoke for 3 hours, at two different coffee shop locations in The Netherlands. None reported wearing braces or other dental devices. The dimensions of the smoking area in location #1 were 5m length x 7m wide x 3.5m high (16 x 23 x 11 ft) and the number of active smokers ranged from 4-16 (mean 8; median 7) during the exposure time. Location #2 was smaller and measured 2 x 7 x 3m (6.5 x 23 x 10 ft) and the number of active marijuana smokers present ranged from 0-6 smokers (mean 2.5; median 2). Two oral fluid specimens per volunteer were collected sequentially using the Quantisal™ oral fluid collection device prior to entering the shop to ensure no recent marijuana smoking, and to maintain a back-up specimen in case of leakage during transport. Two specimens were collected sequentially at the following time points: 20, 40, 60, 120, and 180 min during passive exposure to marijuana. Samples were collected and sealed outside the shop. Volunteers left the shops after 3 hours of exposure time. A final post-exposure specimen was collected between 12 and 22hrs (average 14.6) after leaving the coffee shop. In addition, one oral fluid pad (location #1) and two oral fluid collection pads (location #2) were opened and allowed to remain on the table of each shop throughout the 3 hour timeframe.

Results: THC-COOH (LOQ 5pg/mL) and CBD (LOQ 1ng/mL) were not detected in any of the oral fluid specimens. THC (LOQ 0.5ng/mL) was detected in all specimens up to and including 3 hours from subjects in location #1 (a greater number of active smokers) in concentrations ranging from 0.58 - 6.8ng/mL. In two of those subjects, THC was still detectable 12 hours following exposure (1ng/mL). In the smaller location, THC was detectable three hours after exposure in all subjects (1.3 - 17ng/mL). CBN (LOQ 0.5ng/mL) appeared in the oral fluid of some subjects in both shops 2 - 3 hours after exposure. The pads left exposed in the stores had no THC-COOH present, but were positive for THC at 290 (location #1), 212 and 216ng/mL (#2); CBD 16 (#1) 28 and 38ng/mL (#2); CBN 48 (#1), 40 and 42ng/mL (#2).

Conclusion: The marijuana metabolite THC-COOH has been reported by others to be present in over 98% of marijuana users. In this study, THC-COOH was not detected in oral fluid specimens taken from subjects realistically exposed to marijuana smoke for a period of three hours, using a limit of quantitation of 5pg/mL. Since THC and CBN were detected in many of the specimens, the metabolite THC-COOH must be monitored in oral fluid at a sensitive detection limit in order to eliminate the potential for passive exposure to marijuana.

Key Words: Oral fluid; Passive Exposure; Marijuana

Rapid Method to Screen and Confirm Hair Ketamine and Metabolites in One Hour

Teresa Kam Chi Tsui*¹, Timothy Ho Tong Fok¹, Emmett Wai Keung Law¹, Raphael Wong², Chung Shun Ho.¹

¹Department of Chemical Pathology, Prince of Wales Hospital, Shatin, NT, Hong Kong; ²Branan Medical Corporation, Irvine, CA, USA

Objectives: To develop a rapid sample processing procedure to screen and confirm the presence of ketamine (K) and its metabolites, norketamine (NK) and dehydronorketamine, in human hair samples within 1 h for the investigation of chronic ketamine exposure.

Materials and Methods: Human hair samples were washed with water and acetonitrile (ACN). For the rapid method, 10 mg of washed hair samples were pulverized in a polypropylene tube containing 500 µL 15% ACN and metal beads for 21 min (Precellys, Bertin Technologies). Hair extract was passed through a 0.45 µm filter. The filtrate was screened for K by a lateral flow competitive immunoassay point-of-care (POC) device (Monitect®, Branan Medical Corporation) for 5 min. Samples with a positive screen, were confirmed for K and metabolites by time-of-flight mass spectrometry (TOF-MS) in 17 min [HK Lee et al. *Anal Chim Acta* (2009) 649:80-90]. To evaluate method performance, hair and paired urine samples and history of drug abuse were collected from volunteers in a local substance abuse clinic. Hair K and metabolites were extracted by the rapid method and a reference method, in which 10 mg of dry pulverized hair samples were sonicated in 500 µL 15% ACN at 70°C for 2 h. Hair K content was also quantified by a liquid chromatography tandem mass spectrometry (LC-MS/MS) method with deuterium-labeled K and NK as internal standards.

Results: Cutoff concentrations to detect hair K by the POC device and TOF-MS method were 0.25 and 0.05 ng/mg, respectively. The LC-MS/MS method had a limit of quantitation of 0.01 ng/mg, between-batch precision coefficients of variation <10%, recovery 97-106%, linearity up to 500 ng/mg and was minimally affected by matrix interference. According to case information and urine TOF-MS results, 15 of 36 volunteers were active K abusers, 14 had and 7 had no history of K abuse. Hair samples from all 15 active K abusers screened positive and the presence of K and metabolites were confirmed. In the other 21 volunteers, only 3 hair samples screened and confirmed positive for K and metabolites; paired urine specimens were negative. In addition to K and metabolites, other drugs of abuse and metabolites, e.g. heroin, methamphetamine, cocaine and cough mixture ingredients, were identified with the TOF-MS method. The rapid and reference hair preparation methods had identical hair drug pattern results by TOF-MS, with no significant differences in hair K content by LC-MS/MS. With a reference hair K content of 0.25 ng/mg as cutoff, the POC screening device had a sensitivity of 95% and a specificity of 100%.

Conclusion: A rapid method to screen and confirm hair K and metabolites in 1 h was developed. This approach for hair sample processing may offer a new direction for other drugs of abuse and metabolites.

Key Words: Hair, Ketamine, ELISA, TOF-MS, LC-MS/MS

Elimination Times for Drugs of Abuse in Oral Fluid from Patients with High and Repeated Intake – Case Examples

Elisabeth Leere Øiestad*¹, Vigdis Vindenes¹, Asle Enger², Unni Johansen¹, Knut Hjelmeland¹ and Asbjørg Solberg Christophersen¹
¹Norwegian Institute of Public Health, Oslo, Norway; ²Oslo University Hospital, Oslo, Norway

Objectives: Most studies on detection times for drugs in oral fluid, are based on therapeutic doses of drugs due to ethical limitations on administering higher doses. The detection windows of drugs in oral fluid found in these studies are normally 1-2 days. For use of oral fluid in drug testing for patients in opiate maintenance treatment or prison services, one needs to take into account that repeated and high intake of drugs is common, leading to increased detection times also in oral fluid. The aim of this study was to follow the elimination of illegal and some psychoactive medicinal drugs in oral fluid compared to urine after cessation in patients with high and repeated drug intake.

Materials and Methods: 26 patients undergoing drug detoxification for general drug abuse (opiates, amphetamines, benzodiazepines and cannabis in different combinations) were enrolled in a 10 day study. The intention was to avoid treatment with psychoactive drugs, but most of the patients were treated with daily doses of methadone or buprenorphine, decreasing doses of oxazepam and nitrazepam, zolpidem or zopiclone to induce sleep. Urine samples were collected every morning, whole blood samples once or twice during the first 5 study days if the patient accepted, and oral fluid samples every morning, and evening with simultaneous duplicate samples the first 5 mornings. Urine results were used to follow the elimination and to detect possible new intake. For patients who delivered blood samples, initial blood concentrations were calculated to indicate dose. Urine was screened with EMIT® immunoassay, and confirmed with UPLC-MS-MS or GC-MS. Whole blood was screened with UPLC-MS-MS and confirmed with UPLC-MS-MS or GC-MS. Oral fluid was analyzed directly by a quantitative UPLC-MS-MS method, using an Aquity UPLC BEH C18 column (2.1x50 mm, 1.7µm) and an ammonium bicarbonate pH=8.5 (A) and methanol (B) gradient from 20% B to 90% B. Mass detection was performed by positive ion mode electrospray tandem mass spectrometry and included opiates, benzodiazepines, amphetamines, cannabis (THC) and cocaine.

Results: 10 patients participated for all 10 days, 7 for 6 to 9 days and 9 for 5 days or providing a limited number of subjects. Detection times for the drugs that have not been administered during the detoxification period are reported. The results in urine and oral fluid show good correspondence. The maximum days of detection in oral fluid for 6-MAM (marker of heroin ingestion) was 7 days, 10 days for amphetamine, 10 days for methamphetamine, 7 days for clonazepam/7-aminoclonazepam and 10 days for diazepam/n-desmethyl-diazepam. Episodes of negative followed by positive determination were encountered for most drugs, and in general, lower amounts of drug were detected in the evening than the morning.

Conclusion: The study indicates that heroin, amphetamines and some benzodiazepines can be detected in oral fluid for at least one week after ingestion of high and repeated intake of drugs of abuse. This is important to take into account if interpretation of analytical findings is performed in oral fluid collected from drug abusers

Key Words: Oral Fluid, Drugs of Abuse, Detection Times

LC-HRMS Method for Determination of Levamisole in Hair: Application to Real Samples

Alessandro Nalesso*, Guido Viel, Claudio Terranova, Susanna Vogliardi, Giulia Stocchero, Donata Favretto, and Santo Davide Ferrara

Department of Environmental Medicine and Public Health, Forensic Toxicology and Antidoping Laboratory, University Hospital of Padova, Via Falloppio 50, I-35121 Padova, Italy.

Objectives: Levamisole is an antihelminthic drug approved in several countries for animal use only. This compound has recently attracted the attention of forensic toxicologists because of its widespread use as an adulterant of cocaine. Several cases of severe neutropenia and 'pseudovasculitis' have been associated with exposure to levamisole-containing cocaine. A number of analytical approaches have been developed to detect and quantify levamisole in blood and urine. To the best of our knowledge, there are no published data regarding the identification of this adulterant in keratinic matrices, which maybe suitable for revealing chronic exposure, even when blood and urine both test negative. The aim of the study was to develop a sensitive analytical method to detect and quantify levamisole in keratinic matrices (hair and pubic hair), and to evaluate its applicability in a clinical setting to diagnose chronic exposure to levamisole.

Methods: After external decontamination with methanol (3 mL, 3 min) and acetone (3 mL, 3 min), hair samples (50mg) were pulverized, fortified with IS (d_3 -cocaine, d_3 -benzoilecgonine, and nalorphine) and extracted with a trifluoroacetic acid/methanol solution (10:90 v/v). The organic phase was purified according to a routinely procedure used in our Laboratory for the determination of cocaine and opiates. The dried residue of the organic phase was dissolved with phosphate buffer (pH6, 0.1M) and purified by solid-phase extraction using Bond Elut Certify (Varian) cartridges. Analyte were eluted in basic conditions using a dichloromethane / isopropanol / ammonium hydroxide (80:18:2) mixture. Calibrators and controls were obtained by spiking blank hair with cocaine, benzoilecgonine and levamisole (five points in the range 0.1 - 10.0 ng/mg). Analyses were performed on an LTQ-Orbitrap mass-spectrometer (Thermo Scientific) equipped with an ESI source operating in positive ion mode. Data were acquired in full-scan mode in the range m/z 100-500 with a resolution of 60000 at m/z 400. Separation was carried out on a Waters-T3 Atlantis column (150 mm x 2.1 mm, 3 μ m) by gradient elution at a constant flow of 200 μ L/min. The LC eluent were aqueous ammonium formate 3 mM (solvent A) and acetonitrile (solvent B). The mobile phase was programmed as follows: initial conditions 5% B, linear gradient to 40% B in 8 min, subsequently ramped to 90% B in 2 min, 90% B hold from 10th to 15th min, to 5% B in 1 min. Re-equilibration time was 7 min. The column and samples were maintained at a temperature of 40 °C and 20 °C, respectively.

Results: The proposed method showed good specificity and sensitivity in separating and identifying levamisole in hair and pubic hair. Calibration curves were linear in the range 0.1–10.0 ng/mg. The estimated lower limit of quantification (LLOQ) was 0.1 ng/mg. The method was applied to real samples previously testing positive for cocaine and collected from subjects for which hematological data were available (local driving regranting program). Results showed that, on a pool of 30 samples (length between 2 and 5 cm), levamisole was present in 24 samples (80%) in a concentration interval from 0.1 to 6 ng/mg and with a cocaine/levamisole ratio ranging from 1 to 10. Besides the high prevalence of positive samples, comparison of levamisole distribution in keratinic matrices and hematological data showed that only a minor group of subjects had abnormalities on absolute neutrophil count (less than 10%). Aminorex, the active metabolite of levamisole, was retrospectively sought on the high-resolution full-scan chromatogram by means of the calculated exact mass of its protonated molecular species. No evidence of the presence of this metabolite was obtained.

Conclusions: The proposed method proved to be sensitive, specific and reliable for identifying levamisole in keratinic matrices. The results show that only a small percentage (< 10%) of individuals with detectable concentrations of levamisole in hair seem to be at risk of developing toxic-related neutropenia.

Key Words: Levamisole, Cocaine, Hair, High Resolution Mass Spectrometry, Neutropenia

Oral Fluid Drug Testing of Chronic Pain Patients

Rebecca Heltsley^{*1}, Anne DePriest¹, David L. Black^{1,2}, Tim Robert¹, Lucas Marshall¹, Viola M. Meadors¹, Yale H. Caplan³, and Edward J. Cone⁴

¹Aegis Sciences Corporation, 515 Great Circle Road, Nashville, TN, USA; ²Vanderbilt University Pathology Department, Nashville, TN, USA; ³National Scientific Services, 3411 Phillips Drive, Baltimore, MD, USA; ⁴Johns Hopkins School of Medicine, Baltimore, MD, USA

Objectives: The comparability of oral fluid to urine tests continues to be a subject of interest to many involved in drug monitoring programs. Compliance monitoring of chronic pain patients by oral fluid testing is challenging because of the limited specimen collection volume and the number of licit and illicit drugs that require detection. The objectives of this study were as follows: 1) evaluate the usefulness of oral fluid as a test matrix for monitoring pain patients; and 2) compare results to earlier urine studies of similar populations.

Materials and Methods: Drug prevalence patterns were characterized for oral fluid specimens collected from 6,441 pain patients from 231 pain clinics located in 20 states. Specimens were screened with 14 ELISA assays and non-negative specimens were confirmed by LC-MS-MS for 40 licit and illicit drugs and metabolites.

Results: There was an overall 83.9% positive screening rate (5,401 oral fluid specimens) of which 98.7% (5,329 specimens) were confirmed at \geq LOQ concentrations for at least one analyte. The prevalence of single and multiple non-negative screening results ranged from one to eight drug categories with an average of 1.7 positives per specimen. The positive screening rate for oral fluid was similar to the prevalence of positives (78%) for urine reported in an earlier study (Cone et al., JAT, 32:530-543, 2008). The overall prevalence of confirmed positive drug groups was as follows: opiates > oxycodone > benzodiazepines > methadone \approx carisoprodol > fentanyl > cannabinoids \approx tramadol > cocaine > amphetamines \approx propoxyphene \approx buprenorphine > barbiturates > methamphetamine. Both N- and O-desalkyl-metabolites of opioids and carisoprodol were detected in sufficient abundance in oral fluid (range 30.4%-79.8%) to make them useful in interpreting results. Oral fluid tests revealed that approximately 11.5% of the pain patient study population used one or more illicit drugs (cannabis, cocaine, methamphetamine and/or MDMA). These findings are similar to results reported with urine tests (10.8%) from a similar chronic pain population (Cone, et al., JAT, 32: 530-543). The various combinations of illicit drug use in this study were as follows: cannabis 5.3%, cocaine 4.8%, cannabis and cocaine 0.7%, methamphetamine 0.6%, cocaine and methamphetamine 0.05%, cannabis and methamphetamine 0.03% cannabis and cocaine and methamphetamine 0.02%, cocaine and MDMA 0.02%, and MDMA 0.02%.

Conclusion: In general, the pattern of licit and illicit drugs identified in oral fluid specimens paralleled results observed in earlier studies involving urine testing of pain patient populations. Although drug and metabolite concentrations in oral fluid were lower than observed in urine, the overall qualitative patterns were quite similar. The advantages of oral fluid tests (e.g., non-invasive, observed collection) in combination with demonstrated similarity of results to urine may make oral fluid a viable option for use in chronic pain patient compliance monitoring programs.

Key Words: Oral Fluid, Compliance Monitoring, Prevalence

Developing Exhaled Breath as a Matrix for the Detection of Cannabinoids**Olof Beck**^{1,*}, Sören Sandquist¹, Ilse Dubbelboer², & Johan Franck³¹Department of Medicine, Section of Clinical Pharmacology, Karolinska Institute, Stockholm, Sweden; ²Laboratory for TDM and Clinical Toxicology, Department of Pharmacy, University Medical Center Groningen, Groningen, The Netherlands; ³Department of Clinical Neuroscience, Division of Psychiatry, Karolinska Institute, Stockholm, Sweden.

Objectives: In the field of drugs of abuse testing, urine has been the predominant specimen of choice. Interest in other matrices originates from a need of different detection times and simplicity in sample collection. As a complement to saliva, blood, hair and sweat, we undertook development of exhaled breath for this purpose, following our initial observation that this is a possibility for amphetamine. A key drug is cannabis and the present study was aimed at investigating the possibility of detecting Δ^9 -tetrahydrocannabinol (THC) and 11-nor-9-carboxy-tetrahydrocannabinol (THCA) in exhaled breath after cannabis smoking.

Materials and Methods: Exhaled breath was sampled from 10 regular cannabis users and 8 drug-free controls by directing the exhaled breath by suction through an Empore C18 disk. The disk was extracted with hexane/ethyl acetate and the resulting extract was evaporated to dryness and redissolved in 100 μ L hexane/ethyl acetate. A 3 μ L aliquot was injected onto the LC-MS/MS system and analyzed using positive electrospray ionisation and selected reaction monitoring.

Results: In samples collected 1-12 h after cannabis smoking, THC was detected in all 10 subjects. The rate of excretion was between 9.0-77.3 pg/min. Identification of THC was based on correct retention time relative to tetrahydrocannabinol-d3, and correct product ion ratio. In three samples, peaks were observed for THCA but these did not fulfil identification criteria. No THC or THCA were detected in controls' breath.

Conclusion: These results confirm earlier reports that THC is present in exhaled breath following cannabis smoking and extends the detection time from minutes to hours. The results further support that exhaled breath is a promising matrix for drugs of abuse testing.

Key Words: Exhaled Breath, Cannabis, LC-MS/MS

Proteomic Profiles in Intrauterine Growth Restriction

Donata Favretto*¹, Daniela Cecconi², Francesco Lonardoni², Erich Cosmi³, Marianna Tucci¹, Silvia Visentin³, Giovanni Cecchetto¹, Paolo Fais¹, Guido Viel¹, and Santo Davide Ferrara¹. ¹Dipartimento di Medicina Ambientale e Sanità Pubblica, Padova University, Padova, Italy; ²Dipartimento di Biotecnologie, Laboratorio di Proteomica e Spettrometria di massa, Verona University, Verona, Italy; ³Dipartimento di Scienze Ginecologiche e della Riproduzione Umana, Padova University, Padova, Italy.

Objectives: Intrauterine growth restriction (IUGR) is the major cause of perinatal morbidity and mortality and is also related to enhanced morbidity and metabolic abnormalities later in life. Research has focused on the identification of possible biomarkers for IUGR in the first two trimesters of gestation or perinatally to assess if a pathological status is present before birth and subsequently to determine proper therapy. This evaluation is important also from a legal point of view to assess if there was incorrect care of the expectant mother and fetus. A previous study¹ based on metabolic footprinting of umbilical cord serum (UCS) identified significant differences between IUGR and appropriate for gestational age (AGA) fetuses. In the present study, we took a proteomic approach aimed at uncovering the pathogenetic mechanisms leading to IUGR and the protein modulations, by analyzing fetal UCS and amniotic fluid (AF) by high-resolution two dimensional electrophoresis (2-DE), in combination with high-sensitivity mass spectrometry (MS).

Methods: Ten IUGR and ten AGA full-term singleton neonates were included in the study. Neonatal weight below the 10th customized percentile was considered indicative of IUGR. UCS and AF were obtained; protease inhibitors were added and frozen at -80°C until the analysis. The UCS samples were albumin and IgG depleted; UCS and AF proteins were precipitated with acetone and re-suspended in a solubilizing solution where disulphide bonds were reduced and the cysteine thiolic groups were alkylated. For 2-DE, 450 µL of each sample was separated by pH 3-10 immobilized pH gradients and gradient SDS-PAGE; the proteins were detected by Sypro Ruby staining. The image analysis of the 2-DE gel replicates was performed by PDQuest software (Bio-Rad). Spots showing a statistically significant differential expression between control and IUGR samples were cut out from stained gels and subjected to in-gel trypsin. Peptides from 8 µL of each sample were separated by reversed phase nano-HPLC-Chip technology (Agilent) coupled with a 3D ion trap mass spectrometer (Bruker), using a Zorbax 300SB-C18 analytical column. Automatic switching between MS and MS/MS modes was accomplished. Database searches were conducted using the Mascot MS/MS ion search on all entries of the non-redundant National Center for Biotechnology Information (NCBI) database.

Results: A total of 18 and 13 spots were found to be differentially expressed ($p < 0.01$) in UCS and AF, respectively. The difference in protein expression is calculated by a t-test between the average amount of proteins in the two samples (control and all 10 IUGR). The unique differentially expressed proteins identified by MS/MS analysis were 14 in UCS, and 11 in AF samples. Proteins were validated by Western blot analysis. Functional annotation was obtained by assignment of Gene Ontology (GO) terms for the identified proteins. Protein gene ontology classification indicated that 21% of proteins were involved in inflammatory response, 20% in immune response, while a smaller proportion were related to transport, blood pressure, and coagulation.

Conclusions: IUGR alters the expression of proteins involved in the coagulation process, immune mechanisms, blood pressure and iron and copper homeostasis control. This work offers new insight into IUGR pathogenesis.

Reference: [1] D. Favretto, G. Cecchetto, E. Cosmi, G. Stocchero, S. Vogliardi, G. Frison, C. Terranova, E. Ragazzi, S.D. Ferrara. Searching for biomarkers of disease through an untargeted metabolomic approach. *Ann Toxicol Anal* 21, Suppl. 1, 2009. The International Association of Forensic Toxicologists - TIAFT - 47th International Meeting

Key Words: Intra Uterine Growth Restriction, IUGR, Proteomics, 2-DE Gel

Concentrations of Atomoxetine and its Metabolites in Oral Fluid and Matched Plasma Specimens

Esther Papaseit^{1,4}, Emilia Marchei², Claudia Mortali², Gemma Aznar³, Oscar Garcia-Algar^{3,4}, Magi Farrè^{1,4}, Roberta Pacifici² and Simona Pichini^{*2}

¹Human Pharmacology and Clinical Neurosciences Research Group, Hospital del Mar Research Institute-IMIM-Parc de Salut Mar, Barcelona, Spain; ²Drug Research and Evaluation Department, Istituto Superiore di Sanità, Rome, Italy; ³Neuropediatrics and Department of Pediatrics, Hospital del Mar-Parc de Salut Mar, Barcelona, Spain; ⁴Universitat Autònoma de Barcelona, Barcelona, Spain

Objectives: Atomoxetine (ATX) is a potent inhibitor of the noradrenaline reuptake transporter approved since 2002 for the treatment of attention-deficit/hyperactivity disorder (ADHD) in children, adolescents, and adults as alternative treatment to methylphenidate. Within the framework of a study evaluating the use of alternative biological matrices for therapeutic drug monitoring in paediatric and non paediatric individuals, we investigated the excretion profile of ATX and its metabolites in oral fluid and plasma of a child and five adolescents chronically treated with different doses of ATX. For this study, a method based on liquid chromatography (LC) electrospray ionization (ESI)-tandem mass spectrometry (MS/MS) was developed, validated and applied to matched oral fluid and plasma samples collected at 0, 1, 2, 3, 6 and 12 hours after drug treatment.

Materials and Methods: 0.5 mL plasma and oral fluid fortified with the internal standard (duloxetine) was extracted with two different 2 mL aliquots of tert-butyl methyl ether. Chromatographic separation was carried out on reverse-phase column and a mobile phase of A:40% water – B: 60% 5mM ammonium acetate, 50 mM formic acid, 4 mM trifluoroacetic acid in aqueous acetonitrile (85:15, v/v). The mass spectrometer was operated in positive ion mode using multiple reaction monitoring. The method was validated over the following concentration ranges: 0.5-500 ng/mL and 0.5-50 ng/mL for ATX in plasma and oral fluid respectively, and 0.5-50 ng/mL for 4-OH-ATX and des-ATX in both biological matrices. For all the investigated compounds, good performance in terms of analytical recovery (range:73-87%), selectivity (potentially interfering substances tested: methylphenidate, ritalinic acid, paroxetine and metabolites, fluoxetine and metabolites, principal drugs of abuse and benzodiazepines), stability, imprecision and bias (less than 14%), was obtained (N=5) at three concentrations on 5 different days. Ion suppression ranged from 87 and 101% at the limits of quantification (0.5 ng/mL).

Results: All analytes under investigation were detected in plasma samples with concentrations from 0.6 to 350.4 ng/mL for ATX, 0.5 to 5.8 ng/mL for 4-OH-ATX and 0.5 to 16.3 ng/mL for des-ATX. Conversely, only ATX and 4-OH-ATX were detected in oral fluid samples with concentrations from 0.5 to 26.0 ng/mL and 0.5 to 1.4 ng/mL, respectively. ATX concentrations in oral fluid were one order of magnitude lower than those in plasma and the t_{max} was 2.0 h in plasma and 3.0 h in oral fluid. 4-OH-ATX was found in oral fluid at a peak concentration approximately one fourth those in plasma with a t_{max} of 3.0 h in both matrices. The oral fluid-to-plasma ratio was less than 1 for both analytes.

Conclusion: The LC-MS/MS method allows the determination of ATX and its metabolites in plasma and, for the first time, in oral fluid. The rapid and simple extraction of analytes from different biological matrices, minimum sample preparation and short analysis time are the principal advantages of this method. Preliminary results indicate that both ATX and its metabolites do not diffuse to a large extent into oral fluid, probably due to the high plasma protein binding of these compounds.

Key Words: Atomoxetine, LC-MS-MS, Oral Fluid

Pharmakokinetics of Δ^9 -Tetrahydrocannabinolic Acid A After Intravenous Administration

Ariane Wohlfarth*, Nadine Roth and Volker Auwärter

Institute of Forensic Medicine, University Medical Center, Albertstraße 9, 79104 Freiburg, Germany

Introduction: Δ^9 -Tetrahydrocannabinolic acid A (THCA) is the most abundant cannabinoid in cannabis and is the non-psychoactive biogenetic precursor of THC. THCA rapidly decarboxylates to form THC when heated or smoked and when in alkaline conditions. Contrary to past beliefs, THCA is not completely converted to THC during the smoking process and is therefore detectable in serum and urine after cannabis consumption. We conducted a pilot experiment with four volunteers to characterize the pharmacokinetic properties of THCA, which might be a potential marker for recent cannabis use.

Methods and Materials: THCA was isolated from a crude cannabis extract using flash chromatography. High performance liquid chromatography diode array detection (HPLC-DAD), nuclear magnetic resonance (NMR) and gas chromatography mass spectrometry (GC-MS) analyses demonstrated a purity of 99.8 %, THC was <0.09% and no significant impurities were identified. 5 mg THCA were dissolved in 750 μ l ethanol (70 %) and mixed with Clinoleic®, a fat emulsion for parenteral nutrition, after sterile filtration. The particle size, the size distribution and the stability of the emulsion and of THCA were tested before administration. Four volunteers (3 females, 1 male, aged 27 - 40 years) with no recent cannabis use participated. Blood samples were taken after 5, 10, 15, 20, 30, 45, 60 min, 1.5, 2, 3, 4, 6, 8, 10, 12, 24 and 48 h after intravenous injection of THCA. The intravenous THCA formulation was well tolerated and no adverse effects appeared. Serum samples were extracted by solid-phase extraction. LC separation was performed on a Luna C18 (2) column using gradient elution with 0.1 % formic acid and acetonitrile/0.1 % formic acid. For detection, a QTrap 4000 mass spectrometer (AB Sciex, Foster City, USA) was operated in multiple reaction monitoring (MRM) mode with electrospray ionization monitoring three transitions for THCA and THC. D_3 -THCA (synthesized by an in-house procedure) and D_3 -THC served as internal standards for quantitation. Calibration curves for different sample volumes (50 μ L, 100 μ L and 1.0 mL) were established from 0.1 to 100 ng/mL. The software NCSS served for calculation of the area under the serum concentration-time curve from time 0 to the last measurable concentration (AUC_{0-48h}). All other calculations were performed with Microsoft Excel 2003.

Results and Conclusions: THCA pharmacokinetics can be described by a two-compartment-model. The highest THCA serum concentrations were observed in the first blood sample taken 5 min after injection (C_{max} 870 – 1020 ng/mL). Concentrations decreased to <1 ng/mL within 24 h. THCA was detected in each specimen up to the last sample at 48 h, with an apparent half-life in the last phase of 12.8 to 31.3 h (judging from two measurements). Half-life during the first distribution phase was between 1.1 and 1.6 h. Total systemic clearance did not reach mean values reported for THC and remained low (51 - 131 mL/min). The initial volume of distribution ranged from 0.075 to 0.087 L/kg, reflecting high protein binding comparable to THC. Further research with more subjects – including naïve, occasional and chronic cannabis smokers – after single and multiple THCA doses is necessary to evaluate it as a potential marker of recent cannabis consumption or the marker of the route of cannabis administration.

Key Words: Pharmacokinetic, Δ^9 -Tetrahydrocannabinolic acid A, Intravenous administration

In-Vitro Kinetics of the Human Cytochrome P450 Isozyme Catalyzed Metabolism of the Aporphine Alkaloid Glaucine Using LC-MSⁿ

Golo M. J. Meyer*, Markus R. Meyer, Andrea E. Schwaninger, Dirk K. Wissenbach, and Hans H. Maurer
Department of Experimental & Clinical Toxicology, Saarland University, Homburg (Saar), Germany

Introduction and Objectives: Glaucine (S-5,6,6a,7-tetrahydro-1,2,9,10-tetramethoxy-6-methyl-4H-dibenzo[de,g]quinoline) is an aporphine alkaloid isolated from *Glaucium flavum* (Papaveraceae) and used as an antitussive drug in Bulgaria. Besides its therapeutic use, glaucine was described to be abused as a recreational drug (PI Dargan et al, EJCP, 2008) easily available via the internet leading to symptoms like hallucinations, vomiting, and dizziness. In the rat, it is mainly metabolized by O- and N-demethylation and N-oxidation (GMJ Meyer et al, GTFCh, Mosbach 2011). The aim of the presented study was to assess the involvement of the ten most important cytochrome P450 (CYP) isozymes in these metabolic steps and determination of kinetic parameters using metabolite formation assays.

Materials and Methods: Microsomes of baculovirus infected insect cells with ten individual cDNA expressed P450s (CYP1A2, CYP2A6, CYP2B6, CYP2C8, CYP2C9, CYP2C19, CYP2D6, CYP2E1, CYP3A4 and CYP3A5) were used in initial activity screenings for general involvement of individual enzymes in glaucine demethylation and N-oxidation. Kinetic parameters were determined using pooled human liver microsomes (HLM). After termination of the incubation with acetonitrile, the mixtures were centrifuged and the supernatants analyzed directly without sample work-up by a TF LXQ LC-linear ion trap-MSⁿ (ESI+; Hypersil Gold C18; 100 x 2.1 mm, 1.9 µm; gradient elution, ammonium formate buffer pH 3.5 / acetonitrile).

Results and Conclusion: The major metabolite 10-O-demethyl glaucine (known as liriiferine) was mainly formed by CYP1A2, CYP2C19, and CYP2D6 and the 2-O-demethyl metabolite (predicentrine) by CYP1A2, CYP2D6, CYP3A4, and CYP3A5. N-oxidation was markedly catalyzed by CYP2A6 and N-demethylation by CYP1A2, CYP2C19, CYP2D6, CYP3A4, and CYP3A5. Product formation kinetics for all O- and N-demethylated metabolites followed classic Michaelis-Menten kinetics. Highest enzyme affinity in HLM was observed for the 10-O-demethylation with a K_m value of 166 µM. The K_m values for the 2-O-demethylation and N-demethylation were 553 and 646 µM, respectively. In conclusion, the in-vitro kinetic data are in accordance with the previously presented in-vivo metabolism in rat.

Key Words: Glaucine, Metabolism, Cytochrome P450

Urinary Excretion Kinetics of MDMA and its Phase II Metabolites Following Controlled MDMA Administration to Humans

Andrea E. Schwaninger^{*,1}, Markus R. Meyer¹, Allan J. Barnes², Erin A. Kolbrich-Spargo^{2,3}, David A. Gorelick², Robert S. Goodwin², Marilyn A. Huestis² and Hans H. Maurer¹

¹Dept. of Exper. & Clin. Toxicology, Saarland University, Homburg (Saar), Germany

²Chemistry and Drug Metabolism, NIDA, NIH, Baltimore, MD, USA

³Southwestern Institute of Forensic Sciences, Dallas, TX, USA

Funding provided by Homfor 2010 and the Intramural Research Program of the NIH, NIDA.

Introduction and Objectives: 3,4-methylenedioxymethamphetamine (MDMA) is excreted in human urine as unchanged drug and its phase I and II metabolites. To date, urinary excretion studies following controlled MDMA administration were only performed after conjugate cleavage. The aim of the present study was to investigate intact MDMA glucuronide and sulfate metabolites excretion.

Materials and Methods: Urine specimens from 10 participants receiving 1.0 or 1.6 mg/kg MDMA (JAT 33(8) 2009) were reanalyzed blinded with a Thermo Fisher Exactive LC-HRMS system with a Phenomenex Chirex3012 (250 x 4.6 mm, 5 μ M) column and electrospray ionization (ESI+) after solid phase extraction (C18). Median C_{max} , T_{max} , first and last detection times and total urinary recovery were determined. Ratios of sulfates and glucuronides were calculated and in vitro-in vivo correlation was performed comparing data to previously determined in vitro data (DMD 37 (11) 2009; Toxicol Lett 202 (2) 2011).

Results: Phase II metabolites of 3,4-dihydroxymethamphetamine (DHMA), 4-hydroxy-3-methoxymethamphetamine (HMMA), 3,4-dihydroxyamphetamine (DHA) and 4-hydroxy-3-methoxyamphetamine (HMA) were identified, although only DHMA sulfates, HMMA sulfate and HMMA glucuronide had substantial abundance. Median C_{max} were: DHMA 1.1 and 1.3 μ M, DHMA 3-sulfate 31 and 43 μ M, DHMA 4-sulfate 6.7 and 10 μ M, HMMA 3.5 and 8.2 μ M, HMMA sulfate 45 and 67 μ M, and HMMA glucuronide 33 and 32 μ M following low and high doses, respectively. Good correlation was observed for HMMA measured after acid hydrolysis and the sum of unconjugated HMMA, HMMA glucuronide, and HMMA sulfate ($R^2 = 0.87$). After 1.6 mg/kg MDMA, median % dose excreted into urine over 7d was 37% as 11% MDMA, 1% MDA, 0.2% DHMA, 8% DHMA 3-sulfate, 2% DHMA 4-sulfate, 0.7% HMMA, 10% HMMA sulfate and 4% HMMA glucuronide. The analyte with the longest detection time was HMMA sulfate, at 122 h (low) and 150 h (high). Median HMMA sulfate/glucuronide and DHMA 3-sulfate/4-sulfate ratios for the first 12 h were 2.5 and 6.8, respectively and were in accordance with previous in vitro calculations from human liver microsomes and cytosol experiments.

Conclusions: These are the first data evaluating phase II metabolism in human MDMA users. Human MDMA urinary metabolites are primarily sulfate and glucuronide conjugates, with sulfates present in higher concentrations than glucuronides. This new knowledge will improve urine MDMA and metabolite analysis in clinical and forensic toxicology.

Key Words: MDMA; Phase II Metabolites; In Vitro-In Vivo Correlation

Cannabinoids in Expecterated Oral Fluid from Daily Cannabis Smokers' During Prolonged Monitored Abstinence

Garry Milman*,¹, Allan J. Barnes¹, Jussi Hirvonen², Robert S. Goodwin¹ and Marilyn A. Huestis¹

¹Chemistry and Drug Metabolism, IRP, National Institute on Drug Abuse, NIH, Baltimore, MD, ²Molecular Imaging Branch, IRP, National Institute on Mental Health, Bethesda, MD, USA

Supported by the Intramural Research Program, National Institute on Drug Abuse (NIDA), NIH.

Introduction: Cannabinoid disposition in expecterated oral fluid (OF) from chronic daily cannabis smokers has not been investigated. Expectoration provides undiluted OF and direct determination of drug concentrations. The window of Δ^9 -tetrahydrocannabinol (THC) detection in whole blood and urine from chronic, daily cannabis smokers was recently shown to be at least 7 and 24 days, respectively. Controlled cannabis administration studies are needed to establish which cannabinoid analytes to monitor, appropriate cutoff criteria and OF detection windows, key parameters for improving interpretation of OF tests.

Methods: Daily cannabis smokers provided written informed consent to participate in this IRB-approved research. Participants resided on a closed research unit with continuous monitoring for up to 33 days. OF specimens were collected daily by expectoration, and analyzed by two-dimensional (2D) GCMS with limits of quantification of 0.25 ng/mL for THC, cannabidiol (CBD), and 11-hydroxy-THC, and 1 ng/mL for cannabinol (CBN), all with electron impact and 5 pg/mL for 11-nor-9-carboxy-THC (THCCOOH) with negative chemical ionization.

Results: 30 chronic male daily cannabis users (19-52 years) smoked a median (range) of 9 (1-30) joints/d for 10 (4-38) years. At least one cannabinoid analyte was present in 263 of 578 OF specimens collected over 33 days. THC, CBD and CBN were highest at admission, while maximum THCCOOH concentrations occurred within the first 3 days of abstinence. THC was quantifiable in only 37 specimens (6.4%) at concentrations <64.4 ng/mL; 4 of these contained only THC. THC detection rates in expecterated OF decreased from 78.6 to 17.2 to 0% on admission, and the 1st and 2nd days of abstinence, but 4 participants later had occasional THC-positive specimens (range 0.3-0.6 ng/mL) on days 3 to 28. One subject had no positive OF specimens. Only 2.2% were THC-positive at the recommended Driving under the Influence of Drugs, Alcohol and Medicines (DRUID) confirmation cutoff of 1 ng/mL and 1.9% at the proposed Substance Abuse and Mental Health Services Administration cutoff (2 ng/mL). CBD was detectable in 3 (0.3-2.0 ng/mL) and CBN in 4 (1.0-4.1 ng/mL) specimens, always with concurrent THC and only at admission. No specimen was 11-OH-THC positive. The median OF THCCOOH window of detection was prolonged at 6 days (range 1-30), with concentrations up to 278.7 pg/mL in 259 (44.8%) specimens. For the 1st, 2nd and 3rd weeks of abstinence, 83.4, 36.7 and 26.1% of specimens were THCCOOH-positive. 10 subjects were cannabinoid-positive for up to 24 h with a proposed criterion of THC \geq 2 ng/mL and THCCOOH \geq 20 pg/mL cut-offs.

Conclusions: Simultaneous THC, THCCOOH, CBD and CBN quantification in OF can improve the interpretation of OF test results by suggesting recent cannabis use (CBD and CBN), and eliminating occasional low residual THC concentrations, as well as extending the cannabinoid detection window and reducing the potential for detection of passive cannabis smoke exposure (THCCOOH).

Key Words: Oral Fluid, Tetrahydrocannabinol, Cannabinoids

Pharmacokinetics of Single Dose Clonazepam in Whole Blood and Oral Fluid

Robert Kronstrand^{*1}, Linda Brinkhagen¹, Charlotte Lundström¹, Malin Forsman¹, Ingrid Nyström¹, and Fredrik C. Kugelberg¹. ¹National Board of Forensic Medicine, Dep. Forensic Toxicology, 58758 Linköping, Sweden

Objective: The objective of this paper was to investigate the pharmacokinetics of clonazepam in whole blood and oral fluid (OF) and create prediction models for estimation of time of intake based on concentrations and parent/metabolite ratios.

Methods: Eighteen subjects were given a single oral dose of either 0.5 mg or 2.0 mg clonazepam. Blood samples were drawn in vacutainer tubes and OF was collected using the StatSure device for 72 h post dose. Fourteen of the subjects' data were used to establish the prediction model and data from four were used to test the model. For both whole blood and OF, liquid/liquid extraction at neutral pH with tert-butylmethylether was chosen using either 2 g of whole blood or 0.8 mL of the OF:StatSure buffer mixture. After extraction the solvent was evaporated and reconstituted in 100 µL of 10 mM ammonium formate:acetonitrile (50:50) before chromatography on a 50 × 2.1 mm, 1.7 µm ACQUITY UPLC™ BEH C18 column coupled to an API 4000™ mass spectrometer. Two transitions were monitored for each analyte and the ratio between those as well as the retention time relative to its deuterated internal standard were used for identification. Final calibration curves were from 0.2-20 ng/g for blood and from 0.1-4 ng/mL for OF.

Results: Using sensitive methods, we measured clonazepam and its metabolite, 7-amino-clonazepam in whole blood and OF up to 72h after a single dose. Mean peak blood concentrations were 2.3 and 8.5 ng/g for clonazepam after a single 0.5 and 2.0 mg dose and corresponding mean peak OF concentrations were 0.6 and 1.8 ng/mL. Both peak blood and OF concentrations were dose dependent with approximately 4 times higher concentrations in the subjects given 2 mg. The blood concentrations were not suitable for estimation of the time elapsed after dose since they varied both within and certainly between doses. Therefore, we investigated the use of parent/metabolite ratios to predict the time of ingestion (see figure). A prediction model for blood was constructed from 14 subjects given either 0.5 or 2.0 mg and could best be described by an equation $y=8.8073x^{-0.5772}$ with an $r^2=0.96$. When tested on data from four additional subjects the model overestimated the time of intake at most timepoints (mean +74%) but the data could still be useful in a forensic investigation. The ratio had a low predictive value after 24 h, but a ratio <1 indicates at least 24 h elapsed since intake. A similar relationship could be established between the ratio in OF and time of intake; $y=4.2423x^{-0.5387}$ with $r^2=0.93$.

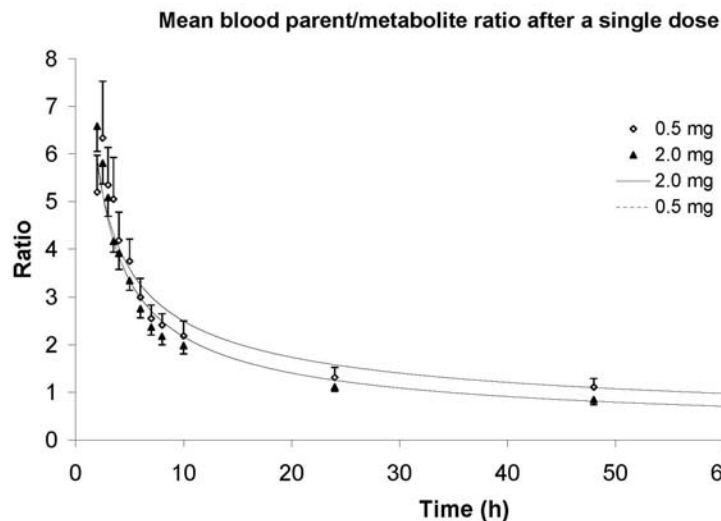

Conclusions: We conclude that ratios between clonazepam and 7-amino-clonazepam in blood and OF are independent of the dose and therefore, might be useful to predict time of intake.

Key Words: Clonazepam, Blood, Oral Fluid, LC-MS-MS

Extended Plasma Cannabinoid Excretion in Chronic Daily Cannabis Smokers During Sustained Abstinence

Mateus M. Bergamaschi*^{1,2}, Erin L. Karschner¹, Jussi Hirvonen³, Regina H. C. Queiroz,² Robert S. Goodwin¹ and Marilyn A. Huestis¹

¹Chemistry and Drug Metabolism, IRP, National Institute on Drug Abuse, NIH, Baltimore, MD, USA. ²School of Pharmaceutical Science, University of São Paulo, Ribeirão Preto, SP, Brazil, ³Molecular Imaging Branch, IRP, National Institute on Mental Health, NIH, Bethesda, MD, USA

Supported by the National Institutes of Health, Intramural Research Program, NIDA

Introduction: According to the 2007 U.S. National Roadside Survey of Alcohol and Drug Use by Drivers, 13.8% were drug-positive in blood, with cannabinoids identified in 8.6% of cases. Recently, THC was quantified in whole blood and plasma from chronic, daily cannabis smokers for up to 7 days of monitored abstinence (Karschner et al *Addiction* 2009). The present study seeks to characterize cannabinoid elimination in chronic daily cannabis smokers' plasma during sustained abstinence.

Methods: Chronic, daily male cannabis smokers resided on a secure clinical research unit under constant 24-hour surveillance. Written informed consent was provided and the National Institute on Drug Abuse Institutional Review Board approved the study. Blood specimens were collected daily on ice, centrifuged and plasma separated within 2 h and frozen at -20°C until analysis. Specimen preparation included extraction on Clean Screen® ZSTHC020 solid phase extraction (SPE) columns (United Chemical Technologies, Bristol, PA), derivatization with BSTFA + 1% TMCS and quantification by two-dimensional GC/MS with cryofocusing (Agilent 6890/5973MSD) in splitless and EI/SIM mode. Limits of quantification (LOQ) were 0.25ng/mL for THC and THCCOOH and 0.50 ng/mL for 11-OH-THC.

Results: 30 chronic daily cannabis smokers provided a total of 553 plasma specimens while residing on the closed unit for up to 33 days. All but one participant was positive on admission with a median THC concentration of 4.2 ng/mL (0.50-30.9 ng/mL). THC decreased over time with detection rates of 95.5, 78.3, 83.3, 76.9 and 57.1% on days 1, 8, 15, 22 and 29, respectively; 3 participants were still THC positive (0.3-1.3 ng/mL) when they left the unit after 30 days of abstinence. 7.1% of specimens had THC ≥2 ng/mL for 20 days. Median 11-OH-THC concentrations were lower (1.8 ng/mL) on admission, with one participant remaining positive up to 19 days. 11-OH-THC detection rates were 54.5, 26.1 and 5.6% on days 1, 8, and 15, respectively. All plasma specimens were THCCOOH positive for 10 days; THCCOOH detection rates were 94.4, 92.3 and 100% on days 15, 22 and 29, respectively; 4 participants were THCCOOH positive (1.0-5.3 ng/mL) after 30 days of abstinence. One subject stayed 33 days and was still THCCOOH positive at discharge. Many participants had negative specimens interspersed with positive specimens for THC and 11-OH-THC; this was less common for THCCOOH.

Conclusion: THC and THCCOOH can be detected in plasma for up to 30 days of monitored abstinence in chronic daily cannabis smokers. Thus, cannabinoid plasma concentrations may not indicate recent cannabis exposure, nor intoxication or impairment, depending upon past smoking history. It is unknown whether residual cannabinoid plasma concentrations are accompanied by cognitive and psychomotor performance impairment. These data have important forensic implications for driving under the influence of drugs and other forensic investigations.

Key Words: Cannabinoids, Δ^9 -tetrahydrocannabinol, Cannabis, Chronic Exposure

Detection of Anabolic Steroid Testosterone in Equine Plasma and Urine after Controlled Administration to HorsesAndre Sukta¹, Brendan Heffron¹, Marc Benoit¹, Lisa Taddei¹, Dawn Folker-Calderon² and **Adam Negrusz***¹¹Animal Forensic Toxicology Laboratory, University of Illinois at Chicago, Chicago, IL, USA; ²Illinois Racing Board, Chicago, IL, USA

Introduction and Objectives: Testosterone (TES) (17 β -hydroxy-4-androsten-3-one) is the male sex hormone and an anabolic steroid produced and secreted by the testes of males and the ovaries of females. The benefits of therapeutic TES administration include enhanced protein synthesis, muscle growth and erythropoiesis. The potential of TES abuse in equine athletes has led to its regulation by horse racing authorities. In this study, the concentrations of TES in equine plasma and urine were measured after IM administration of 500 mg of TES in oil to 3 horses.

Materials and Methods: Plasma was collected post-administration (0-840 h) and kept frozen until analyzed. Eight-point calibration curves for TES in equine plasma were prepared (25-200 pg/mL) with TES-d₃ as an internal standard (IS). The accuracy and precision was determined using control plasma preparations (60 and 140 pg/mL). One mL of plasma aliquots were subjected to a protein precipitation, followed by LLE using 1:1 MTBE : Hexane. After solvent evaporation, samples were reconstituted in mobile phase and analyzed using LC-MS-MS with monitoring of five transitions. Urine samples were collected via Foley catheter introduced into the horse's urinary bladder with a sterile urine collection bag attached to the end of the catheter. Urine samples were collected post-administration (0-1104 h) and kept frozen until analyzed. Six-point calibration curves for both TES-glucuronide and sulfate in urine were prepared (15-480 ng/mL) with TES-d₃ as an IS. The accuracy and precision was determined using control urine preparations (30 and 300 ng/mL). Five mL urine aliquots were hydrolyzed overnight using beta-glucuronidase (pH 5), followed by SPE (C₁₈, 500 mg, 10 mL). After column conditioning and sample addition, TES from glucuronide fraction was eluted using ethyl ether. The second elution from the column (sulfate fraction) was achieved using "solvolysis" solution (50 mL ethyl ether, 10 mL methanol, 3 drops sulfuric acid). The collected eluent was then incubated overnight at 37°C to free TES from its sulfate conjugate. Both eluted fractions were subsequently cleaned using LLE. After solvent evaporation and derivatization (methoxylamine and MSTFA) all samples were analyzed using GC-MS. Standard curves for TES in plasma and urine were linear over the concentration range ($r=0.980$ or higher). The LOD and LOQ for plasma and urine were 3 and 10 pg/mL, and 6 and 10 ng/mL, respectively. The relative accuracy values for control plasma and urine preparations were never greater than 6.7% and 14.5%, respectively.

Results and Conclusions: For all three horses, quantifiable amounts of TES in plasma and urine were detected 72 h, and 9 days, respectively, post-administration. The peak plasma concentrations were found between 30 min and 2 h, and in urine 4 - 6 h. TES concentration in plasma fell below 100 pg/mL (legislative threshold) by day 14 in all three horses.

Key Words: Anabolic Steroids, Testosterone, SPE, GC-MS, LC-MS-MS, Plasma, Urine

The uPA^{+/+}-SCID Chimeric Mouse: A Model for In Vivo Study of Steroid Metabolism

Leen Lootens*¹, Philip Meuleman², Geert Leroux-Roels² and Peter Van Eenoo¹
¹DoCoLab, Ghent University, Belgium; ²CEVAC, Ghent University, Belgium.

Objectives: Doping is widespread and steroid abuse among athletes and adolescents is popular. In addition, the new steroid product market is evolving rapidly. Most steroids are metabolically transformed in the human body, primarily by liver enzymes, to enhance their urinary excretion. Knowledge of steroid metabolism and excretion therefore is necessary to facilitate urinary detection. However, because of serious health risks associated with steroid use and the fact that most steroids are not available as approved pharmaceutical preparations, healthy human volunteer excretion studies are not readily allowed due to ethical concerns. Therefore, an in vivo animal model was proposed: the uPA^{+/+}-SCID mouse with transplanted human hepatocytes (= chimeric mouse) as a model for in vivo urinary steroid metabolism.

Aim: A validation of the model was necessary for its application in human doping research. Three steroids, with human metabolic data available, were selected for administration to the mice to compare with the human excretion profile.

Materials and Methods: A validation protocol was implemented to evaluate the liver-specific steroid metabolic patterns in the chimeric mouse model. The chimeric mice were transplanted with human hepatocytes of Caucasian origin. Androstenedione (AD), 19-norandrostenedione (19-norAD) and methandienone (MTD) were orally administered to chimeric and non-chimeric (control) mice. All mouse urine samples were collected in special metabolic cages for small rodents. Steroids were extracted from the mouse urine after enzymatic hydrolysis and liquid-liquid extraction, followed by analysis on gas chromatography mass spectrometry (GC-MS) or liquid chromatography tandem mass spectrometry (LC-MS/MS).

Results: Pre- and post-administration mouse urines were compared to evaluate the steroids' metabolic profile. One advantage was the endogenous mouse steroid profile did not interfere with the administered compounds. Several reduced and hydroxylated compounds were detected after steroid administration in the chimeric mice and a significant difference was observed compared to the control non-chimeric mice (without transplanted human hepatocytes). 14 of 15 reported human AD metabolites were detected in the chimeric mice, 6 of 7 for MTD and 6 of 6 for 19-norAD. These numbers were lower in the non-chimeric mice. The AD, MTD and 19-norAD metabolic profile in the chimeric mice was comparable to what was previously described in humans. All major known human metabolites of AD (e.g. androsterone and etiocholanolone), MTD (e.g. 6 β -hydroxymethandienone and epimethandienone) and 19-norAD (e.g. 19-norandrosterone and 19-noretiocholanolone) were found in the chimeric mice. A minor metabolite was not detected for MTD; however, new metabolites were found for MTD.

Conclusion: The results from the chimeric mouse model covered a wide range of steroid metabolic pathways previously described in humans. The study confirmed the applicability of the chimeric mouse model as an alternative to in vivo human steroid studies and provided a valuable tool for the investigation of human-liver mediated metabolism and steroid excretion.

Key Words: Steroids, Metabolism, Urine

In Vitro Metabolic Studies Using Homogenised Horse Liver

Jenny K. Y. Wong*, Francis P. W. Tang and Terence S. M. Wan

Racing Laboratory, The Hong Kong Jockey Club, Sha Tin Racecourse, Sha Tin, N.T., Hong Kong, China

Objectives: The study of the metabolism of drugs, in particular steroids, by both in vitro and in vivo methods has been carried out in the authors' laboratory for many years. The in vitro studies were carried out using the microsomal fraction isolated from fresh horse liver. However, the process of isolating liver microsomes is tedious and time consuming. In addition, centrifugation may lead to loss of enzymes, which could be one of the contributing factors to the difference often observed between in vivo and in vitro results. We have therefore investigated the feasibility of using homogenised horse liver instead of liver microsomes with the aim to simplify the procedure, save preparation time and improve the correlation between in vitro and in vivo metabolic studies.

Materials and Methods: Fresh horse liver was cut into 1 cm thick slices and stored immediately at -80 °C. When required, the frozen horse liver was further cut into 1-cm cube pieces and homogenised using a hand-held homogeniser at 4 °C in 2 mL of β -NAD (1.5 mM), glucose-6-phosphate (7.5 mM), $MgCl_2$ (4.5 mM), glucose-6-phosphate dehydrogenase (1 U/mL) and sodium dihydrogen phosphate solution (50 mM; pH 7.4). Incubation studies with the drugs under study (0.5 mg) were carried out at 37 °C for 2 hours with shaking. The reactions were terminated by addition of 2 mL acetonitrile. The mixtures were then centrifuged at 2,100 g for 10 minutes, and the supernatants either extracted twice with ethyl acetate (5 mL) or followed by an additional solid phase extraction using ABS Elut Nexus cartridge. The extracts were evaporated to dryness and the dried residues were analysed directly by LC/MS or derivatised (by trimethylsilylation or acylation) for GC/MS analysis. Control experiments in the absence of either (a) the drug or (b) homogenised liver were performed in parallel.

Results: The preparation of homogenised liver was very simple as no prior centrifugation or preparation steps other than homogenisation of the liver were required. Even though no further purification steps were performed before the homogenised liver was used, the extracts were clean, based on the total ion chromatogram obtained after GC/MS analysis, and was similar to that for liver microsomes. For phase I metabolism, five anabolic steroids, turinabol, methenolone acetate, androst-4-ene-3,6,17-trione, testosterone and epitestosterone were studied. In addition to the previously reported in vitro metabolites, some additional known in vivo metabolites in the equine could also be detected. For example, for methenolone acetate, three additional in vivo metabolites involving deacetylation and hydroxylation or epimerisation were also obtained in vitro using homogenised liver. Namely, 1-methyl-5 α -androst-1-ene-16 α or β , 17 α -diol-3-one and 1-methyl-5 α -androst-1-en-17 α -ol-3-one. Phase II metabolism studies using testosterone as well as morphine and temazepam yielded similar conjugates between the use of homogenised liver and liver microsomes. Stability studies showed that sliced liver stored at -80 °C for over a year has consistently given the same results as fresh sliced liver received on the first day, showing that the liver is stable under these storage conditions. Liver microsomes stored at -80 °C after isolation also showed similar activity.

Conclusion: On the whole, in vitro studies carried out using homogenised liver not only yield more metabolites but also give a better match with in vivo results compared to the use of liver microsomes. As far as we know, this is the first successful use of homogenised horse liver for carrying out phase I and phase II in vitro metabolism studies.

Key Words: Horse Liver, In Vitro, Metabolism

Acute Oral 3,4-Methylenedioxymethamphetamine (MDMA) Effects on Immediate, Short Term and Delayed Memory

Rebecca L. Hartman*¹, Nathalie A. Desrosiers¹, Allan J. Barnes¹, Erin A. Kolbrich-Spargo², Karl B. Scheidweiler¹, David A. Gorelick¹, Robert S. Goodwin³, Elliot A. Stein⁴, and Marilyn A. Huestis¹

¹Chemistry and Drug Metabolism, Intramural Research Program, National Institute on Drug Abuse, NIH, Baltimore, MD, USA;

²Southwestern Institute of Forensic Sciences, Dallas, TX, USA; ³Anne Arundel County Department of Health, Glen Burnie, MD, USA; ⁴Neuroimaging Research Branch, Intramural Research Program, National Institute on Drug Abuse, NIH, Baltimore, MD, USA.

Supported by the Intramural Research Program, NIH, National Institute on Drug Abuse

Objectives: There is evidence that 3,4-Methylenedioxymethamphetamine (MDMA) negatively affects short-term and prospective memory in chronic MDMA users. The aim of this study was to evaluate memory with the Rey Auditory Verbal Learning Test (RAVLT) in MDMA users after acute placebo, low, and high dose of MDMA.

Methods: Written informed consent was obtained for this IRB-approved, randomized, counterbalanced, double-blind, within-subject controlled MDMA administration study. The RAVLT was administered 4 h after placebo, 1.0, and 1.6 mg/kg oral MDMA given in separate sessions at least 6 days apart. Plasma collected 4.5 h post-dose was analyzed by two dimensional-GC-MS according to a previously published method (1). Immediate, final, and total word acquisition, rate of learning, proactive interference, retroactive interference, short-term memory, delayed recall, memory loss, word recognition, confabulation (word not from presented list), perseveration (word repetition), and intrusions (word from interfering list) were assessed. Dose effects on RAVLT scores were compared with Friedman repeated measure of variance. Associations between plasma concentrations and RAVLT scores were evaluated using Spearman's rho correlation. Significance was assigned at two-tailed $p < 0.05$.

Results: Both MDMA doses significantly decreased final ($\chi^2 = 6.12$) and total word acquisition ($\chi^2 = 13.79$), delayed memory ($\chi^2 = 7.39$), and word recognition ($\chi^2 = 6.33$) compared to placebo; MDMA increased the number of confabulations ($\chi^2 = 9.79$), but decreased perseveration ($\chi^2 = 7.36$), ($df = 2$, $n = 18$ for all measures). There also was a trend for lower scores on short-term memory ($p = 0.056$). Median (range) MDMA concentrations 4.5 h post-dose for 18 adult MDMA users (13M, 5F, ages 18-40) were 110.1 (71.2-164.2) and 197.7 (61.8-326.9) ng/mL for low and high doses, respectively. Plasma MDMA concentrations correlated negatively with total word acquisition ($r = -0.333$, $p = 0.014$), and number of perseverations ($r = -0.358$, $p = 0.008$), and positively with number of confabulations ($r = 0.414$, $p = 0.002$).

Conclusions: Acute recreational oral MDMA doses impaired delayed memory and word recognition, but not immediate memory or rate of learning. Increased frequency of confabulation and decreased perseverations were correlated to MDMA concentrations. These data demonstrate significant memory impairment after acute MDMA administration, suggesting an etiology for observed cognitive deficits in chronic MDMA polydrug users.

References

1. E. A. Kolbrich, R. H. Lowe, M. A. Huestis, *Clinical Chemistry* 54, 379 (2008).

Key Words: MDMA, Memory, RAVLT

Studies on the metabolism of three model drugs by fungi colonizing cadavers using LC-MS/MS and GC-MS analysis

Jorge A. Martínez Ramírez*^{1,2}, K. Voigt³, Frank T. Peters¹.

¹Institute of Forensic Medicine, Fürstengraben 23 07743, Jena, Germany; ²Department of Pharmacy Universidad Nacional, Street 45 N°30, Bogota, Colombia; ³Fungal Reference Center Neugasse 24/25 07743, Jena, Germany.

Objectives: It is well-known that cadavers may be colonized by bacteria and fungi. However, there is no information if or to what extent these microbes are capable of metabolizing drugs or poisons and thus changing the concentrations and metabolic patterns of such compounds in postmortem specimens. Therefore, drug metabolism by fungi known to colonize cadavers was studied using three model drugs and two model fungi species.

Materials and Methods: Each model drug (amitriptyline, mirtazapine and zolpidem) was incubated with 10 ml cultures of each of the two model fungi known to colonize cadavers (*Absidia repens* and *Mortierella polycephala*) and the positive control fungus *Cunninghamella elegans*. The drug concentration in the incubation mixtures was 1 mM and the incubations were carried out for 96 h at 25°C (*A. repens* and *M. polycephala*) or 30°C (*C. elegans*). Samples (800 µL) were taken from the incubation mixtures at 24, 48, 72 and 96 h. After centrifugation, one part of the supernatant (50 µL) was analyzed by LC-ESI-MS/MS in the enhanced product ion scanning mode after dilution with mobile phase. The rest of the supernatant was analyzed by GC-MS after liquid-liquid extraction and acetylation or methylation.

Results and Discussion: All model drugs were metabolized by *C. elegans* resulting in three (mirtazapine) to eight (amitriptyline) metabolites per compound. N-demethylation of amitriptyline was observed in incubations with *M. polycephala*. Mirtazapine was metabolized by *A. repens* and *M. polycephala* to N-desmethyl mirtazapine, 8-hydroxy-mirtazapine and mirtazapine-N-oxide and zolpidem to 7-Hydroxy and 7-carboxy-Zolpidem. In incubations with the latter, other previously undescribed metabolites were found, which could be considered marker substances for post mortal fungal metabolism events.

Conclusion: These results suggest that fungi colonizing cadavers may change concentrations and metabolic patterns in postmortem samples, at least of certain drugs. Further studies are needed to assess whether or not this may be important in case interpretation.

Key Words: Metabolism, Fungi, Cadavers

Demonstration of Postmortem Redistribution of 3,4-Methylenedioxymethamphetamine and 3,4-Methylenedioxyamphetamine in A Case Of Ecstasy Intoxication

W. Lee Hearn^{*1}, Diane Boland¹, Stacey Simons¹, Julio Cofino¹, and Samantha Tolliver²

¹Miami-Dade County Medical Examiner Department, Miami, FL, USA ²ExperTox, Inc., Deer Park, TX, USA

Objective: This study examines 3,4-methylenedioxymethamphetamine (MDMA) and 3,4-methylenedioxyamphetamine (MDA) concentrations in antemortem and postmortem specimens in order to estimate the magnitude of postmortem redistribution in a case with 29 hr survival and 24 hr postmortem interval.

Methods: MDMA and MDA were isolated using solid phase extraction, derivatized with MBTFA:ethyl acetate, and analyzed using gas chromatography/mass spectrometry (GC-MS) with the appropriate deuterated internal standards. Ions monitored for MDMA included m/z 154, 135, 162, and 289 and for MDA m/z 162, 135 and 275. Quantitation was based on m/z 154 for MDMA, 162 for MDA, 158 for MDMA-d₄ and 167 for MDA-d₄. Linear calibration curves from 10 to 1000 ng/mL were used to calculate the concentrations of MDMA and MDA in samples and controls. The first order elimination equation was used to estimate the elimination half-life ($t_{1/2}$) and perimortem concentration of MDMA.

Results: Blood and Vitreous fluid analysis by headspace GC-FID detected ethanol (0.19 g%) in both samples. Initial urine screening by EMITTM and GC-MS detected only lidocaine, however GC-MS analysis of a basic extract of antemortem blood detected MDMA. Quantitative analysis of antemortem and postmortem samples yielded the concentrations shown in the following table:

AM Sample – Time (min)	MDMA (mg/L) (mg/L)	MDA (mg/L) (mg/L)	Ethanol (g %) (g %)
04:20	0.776	0.035	0.19
04:25	0.817	0.036	0.19
04:31	0.761	0.032	
06:34	0.817	0.033	
13:20	0.482	0.019	
Postmortem Sample			
Iliac Vein Blood	1.038	0.075	
Aorta Blood	3.755	0.253	
Vitreous Fluid	2.653	0.163	

The $t_{1/2}$ and perimortem concentrations were estimated to be 8.9 hours and 0.11 mg/L, respectively. The MDMA concentration in Iliac Vein blood was 10x the estimated perimortem concentration. The Aorta/Iliac Vein concentration ratio was 3.6:1. The Vitreous fluid/Iliac Vein concentration ratio was 2.6:1. MDA concentrations were higher in all postmortem samples than in any antemortem blood.

Conclusion: MDMA, with an apparent Volume of Distribution of 5-9 L/kg, undergoes extensive PMR.

Key Words: Postmortem Redistribution, Methylenedioxymethamphetamine, Ecstasy

Influence of Ante Mortem Perfusion on Autopsy Blood Ethanol Concentration

Pascal Kintz* and Marion Villain

X-Pertise Consulting, 84 route de Saverne, 67205 Oberhausbergen, France

Objectives: An injured subject receiving transfusions of blood or fluids may have a diluted sample at autopsy. Calculation of blood ethanol concentration at the time of the event can be challenging, given potential ante mortem dilution. From a complete literature survey, it seems that this topic has been minimally addressed. Our strategy for dealing with cases in which dilution has occurred will be reviewed in this presentation.

Case: Before death, the victim (male, 1.70 m, 70 kg) was perfused (left elbow) with a total volume of 3250 mL (1500 mL NaCl 0,9 %, 1500 mL Voluven, 250 mL sodium bicarbonate). He was pronounced dead about 30 min later. The blood alcohol concentration (right vena cava) in the autopsy sample was 0.3 g/L. The judge in charge of the case requested us to explain the influence of the perfusion in the final blood alcohol concentration.

Discussion: Since nonalcoholic liquid is being added to the body, the subject's alcohol concentration obviously will be affected to some degree. Intravenous fluids are administered in roughly the same amounts as fluids lost by other paths, in order to maintain blood pressure. The first approach can be the calculation of the dilution factor. Alcohol is distributed in total body water, rather than in blood. Therefore, if 3.25 L of fluids are given to a 70 kg male, with a volume of distribution of 0.66 L/kg, the total body water, and consequently the blood alcohol, has been diluted by less than 10%. The premise presented for estimating the effect of dilution is mostly valid when the ethanol has reached equilibrium in the total body water (time dependent). A higher degree of dilution of the blood alcohol concentration can occur when ethanol distribution into the total body water has not reached equilibrium. Comparisons of autopsy results with recent pre-incident blood analysis results for hemoglobin, albumin or total proteins can be of great interest to evaluate the dilution factor. If one gets results within the same range, this will make allowances for the uncertainty in each calculation. In this case, the dilution factor was estimated to be in the 7 to 10% range. The contribution of the sampling and infusion site was minimal, given the physician was careful to draw the ethanol concentration from the opposite side of the infusion.

Conclusion: Considering the relatively small amount of fluid added compared to the mean distribution volume of ethanol, the effects of ante mortem intravenous fluids are minimal.

Key Words: Ethanol, Perfusion, Interpretation

Characterization of Single Nucleotide Polymorphisms of Cytochrome P450 in an Australian Deceased Population

Jennifer Lucinda Pilgrim^{1*}, Yarimar Ruiz⁴, Alejandro Gesteira³, Dimitri Gerostamoulos^{1,2}, Raquel Cruz⁵, Angel Carracedo^{3,4,5} and Olaf H. Drummer^{1,2}

¹Department of Forensic Medicine, Monash University, ²Victorian Institute of Forensic Medicine, ³Fundación Pública Galega de Medicina Xenómica – SERGAS, Hospital Clínico Universitario de Santiago, ⁴Laboratorio de Genética Forense, Instituto de Ciencias Forenses Luis Concheiro, Universidade de Santiago de Compostela, ⁵Centro de Investigación Biomédica en Red de Enfermedades Raras (CIBERER)

Objectives: CYP450 isozymes are responsible for the metabolism of up to 90% of commonly used drugs. Single nucleotide polymorphisms (SNP) of CYP1A2, 2C9, 2C19, 2D6, 3A4 and 3A5 were analyzed in Australian deceased samples to determine if there was an over-representation of individuals with a genetic predisposition to altered drug metabolism in cases attributed to drug toxicity.

Materials and Methods: Cases were identified where one or more of 7 commonly used serotonergic drugs were detected in postmortem samples. These drugs were tramadol, fluoxetine, paroxetine, sertraline, citalopram, venlafaxine and MDMA. DNA was extracted using the Chelex method followed by ethanol precipitation. Genotyping involved SNaPshot® for the identification of CYP2D6 SNPs and Sequenom® for all other SNPs.

Results: 30 SNPs were genotyped in 486 postmortem cases, of which 17 allelic variants were identified. There were 27 cases (6.1%) that were CYP2D6 poor metabolizers (PM) and an additional eight cases (1.7%) that were CYP2C19 PMs. This included 17 deaths attributed to drugs, 10 to natural disease, 7 to external causes and one unascertained death. Around 31% of the cases were CYP2D6 intermediate-poor metabolizers, with a number of cases exhibiting drugs that were likely to have caused pharmacokinetic or pharmacodynamic interactions, such as serotonin reuptake inhibitors, tramadol, methadone and oxycodone. There was no correlation between cause of death and CYP2D6 metabolizer status, but there was a significantly higher prevalence of PM genotypes for CYP2D6 amongst males compared with females ($p=0.0065$). Increased enzyme activity was also indicated by the presence of hyperinducible variants such as CYP1A2*1F, which was observed at a frequency of 48%.

Conclusion: A range of genetic variants which may lead to altered metabolism in susceptible individuals was observed. CYP2D6*4 and CYP2C19*2, which denote poor metabolism, were observed at a frequency of 5.7% and 1.7% of the samples, respectively. Genetic predisposition did not appear to play a leading role in the cause of death in this sample of Australian deceased individuals.

Key Words: CYP450, Adverse Drug Reaction, Serotonergic Drugs

Opioids in Fatalities

Margareeta Häkkinen, Terhi Launiainen, Erkki Vuori and **Ilkka Ojanperä***

Hjelt Institute, Department of Forensic Medicine, PO Box 40, FI-00014 University of Helsinki, Finland

Objectives: Various opioids are frequently associated with fatal poisonings. However, the published reports of fatal opioid poisonings seldom allow for comparison of opioid poisonings versus cases with other causes of death. The present study takes advantage of the high medico-legal autopsy rate and the comprehensive post-mortem toxicology database generated in Finland. All opioid-positive subjects registered into the database are divided into two groups: opioid poisonings, and opioid-related cases with other primary causes of death.

Materials and Methods: The data consisted of all the death cases in Finland in which the case was registered and a comprehensive post-mortem toxicological analysis performed in 2000-2008. During the study period toxicological analysis were performed for 53328 subjects, of those 40020 were men. The subgroup of 14-44-year-old deceased comprised 12891 cases (10182 men), and one or several opioids were detected in 1363 cases (1103 men). The post-mortem database included a forensic pathologist's referral, laboratory analysis results, and information extracted from the death certificate issued by a forensic pathologist. The referral contained a brief description of the circumstances of death and the main autopsy findings. The laboratory data contained analysis results for opioids, benzodiazepines, alcohol and other drugs. Information from the final death certificate included the age and gender of the deceased and the cause of death with contributing factors according to the International Classification of Diseases (ICD-10) and the manner of death (World Health Organisation, WHO).

Results: The most commonly detected opioids were codeine, buprenorphine and tramadol. In codeine, buprenorphine and tramadol positive cases, the particular drug was the main cause of death in 146 (37%), 182 (47%) and 115 (33%) cases, respectively. In codeine poisonings, the median codeine concentration (1.4 mg/l) was significantly ($p < 0.001$) higher than in cases with other causes of death (0.07 mg/l). In codeine poisonings, the manner of death was accidental, suicide, unclear or disease in 43%, 40%, 16%, and 0% of cases, respectively. In buprenorphine poisonings, the median buprenorphine concentration (1.4 µg/l) and the buprenorphine/norbuprenorphine ratio (1.8) were significantly ($p < 0.05$) higher than in cases with other causes of death (1.2 µg/l and 0.86, respectively). In most buprenorphine poisonings (92%), no opioids other than buprenorphine were involved, but benzodiazepines and alcohol were found in 82% and 58% of cases, respectively. In buprenorphine poisonings, the manner of death was accidental, suicide, unclear or disease in 94%, 1.6%, 0.8%, and 0.5% of cases, respectively. In tramadol poisonings, the median tramadol concentration (5.3 mg/l) was significantly ($p < 0.001$) higher than in cases with other causes of death (0.6 mg/l). In tramadol poisonings, the manner of death was accidental, suicide, unclear or disease in 55%, 31%, 14%, and 0 % of cases, respectively.

Conclusion: Fatal buprenorphine poisonings differ from fatal codeine and tramadol poisonings in many respects. In buprenorphine poisonings, the manner of death is almost exclusively accidental, buprenorphine blood concentrations are of little interpretive value, and benzodiazepines or alcohol are nearly always found but no other opioids.

Key Words: Opioid, Fatal Poisoning, Post-Mortem Toxicology

Alcohol is Associated with the Partitioning of Morphine Between Blood and Vitreous Humour Compartments in Deaths Associated with the Use of Heroin.

Duncan W. S. Stephen*¹, James H. K. Grieve², Iain Clunie¹, Linda McKay¹, William G. Simpson¹, Bernard L. Croal¹
¹Department of Clinical Biochemistry, Aberdeen Royal Infirmary, Aberdeen, Scotland; ²Forensic Medicine Unit, Department of Pathology, Aberdeen Royal Infirmary, Aberdeen, Scotland.

Introduction: Drug misuse in the North of Scotland has increased rapidly over the last 10 years with the number of Heroin-related deaths alone now over 40 per annum. Notwithstanding the post-mortem phenomena of site-dependency and redistribution in the interpretation of a drug level, blood is the specimen of choice for ascertaining the pharmacological effect (therapeutic or toxic) of a drug in a deceased individual. However, on occasion when blood is unavailable at autopsy vitreous humour is often obtainable. It can be collected from an anatomically isolated area making it a biological fluid more resistant to putrefactive changes compared to other body fluids. Due to such stability, it is a suitable specimen for comparative toxicological study. In this presentation, we extend our initial study of the observed positive correlation between Morphine levels in the two fluid compartments to include the influence of the presence of Alcohol in blood and urine upon this association in (Heroin)-related deaths.

Materials and Methods: Post-mortem blood and vitreous humour samples were taken from Procurator Fiscal cases (n = 146) suspected of being Heroin-related. Specimens were spiked with Nalorphine (internal standard) and pre-treated with water prior to solid phase extraction. Following elution with dichloromethane: isopropyl alcohol (80:20), samples were evaporated to dryness under nitrogen and either (a) derivatised with BSTFA before being reconstituted in ethyl acetate and analysed by GC-MS or (b) reconstituted in Methanol:Water:Formic Acid (50:50:0.1) and analysed by LC-MS.

Results: Linear regression related vitreous humour Morphine values to blood Morphine levels in cases of death due to Heroin use where (a) no Alcohol was found in the blood according to the equation ($p < 0.001$; $r = 0.53$): Blood Morphine level (mg/L) = (Vitreous humour Morphine level (mg/L) \times 1.397) + 0.133; (b) Alcohol was present in blood at a concentration greater than 80 mg/100mL according to the equation ($p < 0.001$; $r = 0.86$): Blood Morphine level (mg/L) = (Vitreous humour Morphine level (mg/L) \times 2.761) + 0.009. t-Test analysis indicates Alcohol has a significant association upon the correlation of vitreous humour and blood Morphine concentrations in deaths associated with Heroin use (t-stat 1.886; $p = 0.03$). Furthermore, the relationship between blood and vitreous humour Alcohol may give some indication of the survival post-ingestion. Using this estimate, we found a temporal relationship between blood and vitreous humour Morphine levels: higher in blood initially, becoming higher in vitreous humour after longer time intervals between last ingestion and death.

Conclusion: The strength of positive correlation between Morphine concentrations in vitreous humour and blood was greater when Alcohol was present in blood compared to Alcohol being absent. This mechanism of this action is unclear but may be related to Alcohol increasing the permeability of cell membranes to permit greater partitioning and distribution of Morphine between the two fluid compartments.

Key Words: Alcohol, Morphine, Vitreous, Blood

Benzodiazepine-Like Hypnotics in Postmortem Blood: Zopiclone- and Zolpidem-Related Fatalities in Norway**Joachim Frost***^{1,2}, Ivar S. Nordrum^{1,2}, Lars Slørdal^{1,2}¹St Olav University Hospital, Trondheim, Norway; ²Norwegian University of Science and Technology, Trondheim, Norway

Objective: The benzodiazepine-like hypnotics zopiclone and zolpidem, which are widely prescribed for short-term treatment of insomnia, were initially believed to possess less abuse potential and toxicity than benzodiazepines. This has been challenged by reports of abuse and intoxications, where high concentrations of zopiclone and zolpidem alone or in combination with other drugs were measured. We reviewed zopiclone- and zolpidem-related deaths in four Norwegian counties (total population approx. 850,000) over a four-year period.

Materials and Methods: A total of 652 consecutive forensic postmortem toxicological specimens were received and analysed in our laboratory between September 2006 and June 2010. Zopiclone and zolpidem were detected in femoral blood in 48 and 8 cases, respectively, of which 19 and 0 cases, respectively, had blood concentrations above the lower threshold for toxicity according to TIAFT criteria (0.15 mg/L zopiclone and 0.5 mg/L zolpidem). Complete autopsy records for these 19 cases were obtained and reviewed.

Results: In the 19 cases reviewed, femoral blood zopiclone concentrations ranged from 0.17 to 4.7 mg/L. Various other drugs and/or ethanol were detected in 17 cases (89%). From the 19 reviewed cases, 2 deaths (11%) were attributed to zopiclone intoxication, 12 deaths (63%) to intoxication with multiple substances including zopiclone, and 5 deaths (26%) to other causes. In the 2 deaths attributed to zopiclone, femoral blood concentrations were 4.7 and 3.6 mg/L. In a particular case where zopiclone was the only toxicological finding, a femoral blood concentration of 3.7 mg/L was measured, and death was attributed to multiple injuries after a fall.

Conclusion: Zopiclone is a prevalent finding in specimens from Norwegian forensic autopsy cases. We encountered no cases with zolpidem blood levels exceeding the TIAFT toxicity threshold. To our knowledge, the fatal zopiclone concentration of 4.7 mg/L is the highest postmortem femoral blood zopiclone concentration ever reported. Considering zopiclone's widespread use and its apparent toxicity, particularly when combined with ethanol or other CNS depressant drugs, zopiclone is of clinical and epidemiological significance and prescribing physicians should be aware of potential toxicity of this drug.

Key Words: Zopiclone, Zolpidem, Forensic, Toxicology

Investigation of Markers to Indicate and Distinguish Death Due to Alcoholic Ketoacidosis, Diabetic Ketoacidosis and Hyperosmolar Hyperglycemic State Using Post-Mortem Samples

Joanna Hockenhull¹, Waljit Dhillon², Rebecca Andrews¹, Sue Paterson*¹

¹Toxicology Unit, Imperial College London, St Dunstan's Road, London W6 8RP; ²Imperial Centre for Endocrinology, Imperial College London, Hammersmith Hospital, Du Cane Road, London W12 0NN

Introduction and Objectives: Acetone and beta-hydroxybutyrate (β HB) are markers used to demonstrate ketoacidosis. Acetone usually accounts for only 2% of all ketone bodies while β HB accounts for 78%. Acetone is relatively quick and easy to detect and identified during analysis for ethanol, a procedure that is routine on virtually every post-mortem case, while β HB involves a specific assay. The study was undertaken to show whether it was necessary to analyse for β HB in cases where acetone was not present.

Materials and Methods: Data were collected from 191 post-mortem cases where post-mortem blood β HB and acetone concentrations and vitreous humor glucose concentrations (available for 102 cases) were measured.

Results: β HB was detected at pathologically significant concentrations ($>250 \mu\text{g/mL}$) in 49 cases with a history of alcoholism, diabetes or both and in 12 cases with no notable history. There was no significant difference between alcoholics, alcoholic diabetics and unknown cases but the β HB values acquired from diabetics were significantly different ($p < 0.05$) from the other three groups. The median value and interquartile range were also notably higher for diabetics. However, the concentration range of β HB (Alcoholics: 347-1789 $\mu\text{g/mL}$, Diabetics: 285-1788 $\mu\text{g/mL}$, Alcoholic Diabetics: 313-1741 $\mu\text{g/mL}$, Unknown: 361-1372 $\mu\text{g/mL}$) was relatively consistent over all categories, showing the β HB value alone could not be used to distinguish diabetic ketoacidosis (DKA) from ketoacidosis resulting from other causes. Acetone was detected in 71 cases (Alcoholics: 5-52 mg/dL, Diabetics: 8-66 mg/dL, Alcoholic Diabetics: 6-44 mg/dL, Unknown: 13-95 mg/dL). β HB was $>250 \mu\text{g/mL}$ in 61 of these cases, elevated (50-250 $\mu\text{g/mL}$) in 9 cases and normal ($<50 \mu\text{g/mL}$) in 1 case. There were no cases where a significant β HB concentration was detected without acetone present at a concentration $>2 \text{ mg}/100\text{mL}$. Nine cases with substantial β HB concentrations had acetone 5-8 mg/dL, which is below the limit considered indicative of ketoacidosis when using acetone as a marker. Vitreous humor glucose was measured in 102 cases and was detected $>6.9 \text{ mmol/L}$ in 31 cases. Of these cases, 25 (15 diabetics, 1 alcoholic, 4 alcoholic diabetics and 5 unknown cases) had substantial concentrations of β HB present, indicating death due to DKA, with glucose 7.5 – 76.3 mmol/L. There were also 6 cases (1 diabetic and 5 unknown cases) with a glucose concentration $>6.9 \text{ mmol/L}$ (12.2 – 52.9 mmol/L), but no significant ketone bodies were present, indicating possible hyperosmolar hyperglycemic state.

Conclusions: In post-mortem cases, β HB concentrations were a better indicator of ketoacidosis than acetone concentrations but β HB only needs to be measured in cases where acetone is present. Glucose measurement in vitreous humor is essential to distinguish DKA and ketoacidosis from other causes and to detect hyperosmotic hyperglycemic state, a condition that may cause death.

Key Words: Alcoholic Ketoacidosis, Diabetic Ketoacidosis, Hyperosmolar Hyperglycemic State

O51

Ethyl Glucuronide and Ethyl Sulfate in Placenta and Fetal Tissues by LC-MS/MS: Biomarkers of Placental Ethanol Transport

Luca Morini^{*1}, Maria Falcón², Simona Pichini³, Oscar Garcia-Algar⁴, Paolo Danesino¹, Angelo Groppi¹ and Aurelio Luna²

¹Department of Legal Medicine, Forensic and Pharmaco-Toxicological Science, University of Pavia, Italy; ²Department of Legal Medicine, Universidad de Murcia, Murcia, Spain; ³Istituto Superiore di Sanità, Rome, Italy; ⁴Unitat de Recerca Infància i Entorn (URIE), Institut Municipal d'Investigació Mèdica-Hospital del Mar, Barcelona, Spain.

Objectives: The aim of this study was to develop a method for the determination of ethyl glucuronide (EtG) and ethyl sulfate (EtS), two ethanol metabolites, in placental and fetal human tissues early in pregnancy, as potential biomarkers of transplacental ethanol exposure of the fetus.

Methods: Placental and fetal tissue samples were obtained from women undergoing voluntary termination of pregnancy at 12 weeks gestation. After addition of D₅-EtG and D₅-EtS as internal standards, samples were deproteinized with acetonitrile, centrifuged and diluted 1:10 with bi-distilled water. An 8 µl aliquot was injected directly into an LC-MS/MS system.

Results: A limit of detection (LOD) of 3 ng/g and a lower limit of quantification (LLOQ) of 5 ng/g were achieved for both metabolites. Upper limit of linearity (ULOL) was set at 1000 ng/g. The method showed high selectivity for the two monitored compounds. Inter-day and intra-day imprecision and inaccuracy were always lower than 15%. The chromatograms showed a negligible matrix effect on EtS while EtG signal in placental tissues was partially decreased, reaching a maximum ion suppression of 40%. The validated method was applied to 70 samples (35 placentas and 35 fetal tissues). Eight of 70 samples tested positive for EtG and EtS (4 positive placenta and 4 positive fetal tissues samples). EtG was always present at higher concentration than EtS. The mean (± standard deviation) placenta/fetal tissue ratio for EtG was 2.9 ± 0.9 while EtS showed a ratio of 1.7 ± 0.7. EtG/EtS ratio in placenta was 5.6 ± 1.9, while in fetal tissues 10.7 ± 3.7.

Conclusions: Preliminary results confirm these metabolites are present in both tissues. Further studies on placental perfusion of EtG and EtS are needed in order to corroborate the hypothesis of a transplacental exposure leading to increased EtG and EtS in the fetus relative to placenta.

Key Words: Ethyl-Glucuronide, Ethyl-Sulfate, Placenta, LC/MS/MS

Detection of Ethylglucuronide and Ethylsulfate in Dried Blood Spots

Ana Hernández Redondo*, Wolfgang Weinmann and Stefan König
Institute of Forensic Medicine, Bern, Switzerland

Introduction and Objectives: In the past few years, research focused on developing methods for detecting alcohol biomarkers with a longer detection window than alcohol (usually limited to <12 h) for application in alcohol withdrawal programs, in workplace monitoring or for abstinence control. Ethyl glucuronide (EtG) and ethyl sulfate (EtS) are formed after a phase II conjugation reaction of ethanol with uridine diphosphate-glucuronosyltransferase (UGT) and sulfotransferase (SULT), respectively. Due to their slower elimination, these minor direct metabolites of ethanol can be detected in body fluids, even if ethanol itself is no longer detectable or decreased to low concentrations. The dried blood spot (DBS) technique is a blood sampling method with full validation for the analysis of EtG and EtS by LC-ESI-MS/MS.

Materials and Methods: Both substances were spiked in blood and subsequently allowed to dry on a specimen collection card. The dried blood spots were removed using a manual punch (5 mm diameter) and extracted with methanol, requiring less than 30 µL of blood for the analysis. Instrumentation consisted of a CTC PAL autosampler, an Agilent 1200 series HPLC and a QTrap 3200 mass spectrometer (AB Sciex). EtG and EtS were separated at 40°C on a hydrophilic-encapped, ether-linked phenyl reversed phase column (Synergi Polar-RP 150 × 2 mm, 5 µm) with a guard column, both from Phenomenex. To enhance signal intensity, 2-propanol was added post-column by a T-union before the effluent enters the electrospray ion source.

Results: The linearity was assessed in the range 0.1-10.0 µg/mL blood, with a correlation coefficient of 0.9993. The lower limit of quantification (LLOQ) and the limit of detection (LOD) were 0.1 µg/mL and 0.070 µg/mL, respectively. The intra- and inter-day precision and accuracy were studied at four different concentration levels (0.1, 0.3, 2.0 and 8.0 µg/mL) and were always less than 11% (n=6). The stability of EtG and EtS in DBS was also studied at four different concentration levels over different time periods (1, 2 and 3 weeks) at two different storage temperatures (25 and -4°C), showing a decrease in the EtG and EtS concentration of ca. 20% in samples stored at room temperature and 10% with refrigerated storage. In addition, several factors that potentially affect DBS assay quantitation were investigated, such as punch size, DBS punch-out location and the volume of the blood sample pipetted onto the specimen collection cards.

Conclusions: Sampling of DBS can be performed by non-medical personal; this will shorten, in cases of drunken driving, the time-gap between the offense and blood collection. Apart from that, the inconvenience of venous sampling and the large amount of blood extracted are overcome.

Key Words: Ethyl Glucuronide, Dried Blood Spots, LC-ESI-MS/MS

Diagnostic Performance of Ethyl Glucuronide in Hair for the Investigation of Alcohol Drinking Behavior: A Comparison with Traditional Biomarkers

Frank Sporkert*, Hicham Kharbouche, Christian Staub, Marc Augsburger, Patrice Mangin
University Center of Legal Medicine Lausanne-Geneva, Rue du Bugnon 21, 1011 Lausanne, Switzerland

Objectives: Ethyl glucuronide (EtG) in hair has emerged as a useful biomarker for detecting alcohol abuse and monitoring abstinence. However, there is a need to establish a reliable cutoff value for the detection of chronic and excessive alcohol consumption.

Methods: One hundred and twenty-five subjects were classified as teetotalers (43), low-risk drinkers (44), at-risk drinkers or heavy drinkers (38). The gold standard for subjects' classifications was based on a prospective daily alcohol self-monitoring log. Subjects were followed for a 3 month period. Twenty-one alcohol dependents were used as a positive control. EtG was determined using our validated GC-MS/MS detection method [1]. CDT was measured by CE-UV using the Ceofix CDT-Kit. GGT, AST and ALT were analyzed by immunochemical methods on a Dimension XPand. The EtG diagnostic performance was evaluated and compared with ASAT, ALAT, γ GT and CDT using statistical methods.

Results: A cutoff of >9 pg/mg EtG in hair, suggesting an alcohol consumption of >30 g/day (at-risk drinkers) and a cutoff of >25 pg/mg, suggesting a consumption of >60 g/day (heavy drinkers). EtG concentration <9 pg/mg were related with low risk drinking. In the case of abstinence, EtG was not detected except for two cases. The EtG diagnostic performance was significantly better than any of the hepatic biomarkers alone. EtG, as a single biomarker, yielded a stronger or similar diagnostic performance in detecting at-risk or heavy drinkers, respectively, than the best combination of traditional biomarkers (CDT and γ GT). The combination of EtG with traditional biomarkers did not improve the diagnostic performance of EtG alone. EtG demonstrated a strong potential to identify heavy alcohol consumption, whereas the traditional biomarkers failed to do so. EtG was not significantly influenced by gender, body mass index or age.

Conclusion: Hair EtG definitively provides an accurate and reliable diagnostic test for detecting chronic and excessive alcohol consumption. The proposed cutoffs can be recommended for clinical and forensic use.

Reference:

[1] Kharbouche H, Sporkert F, Troxler S, Augsburger M, Mangin P, Staub C. Development and validation of a gas chromatography-negative chemical ionization tandem mass spectrometry method for the determination of ethyl glucuronide in hair and its application to forensic toxicology. *J Chromatogr B Analyt Technol Biomed Life Sci* 2009;877:2337-43.

Key Words: EtG, Hair, Diagnostic Performance

Predicting Blood Alcohol Concentrations after Social Drinking in Human Subjects where Absorption may be Incomplete

Samantha Coward*, Alexandra Park, Sima Mala and Allan Stowell
ESR, Kenepuru Science Centre, 34 Kenepuru Drive, Porirua 5022, New Zealand

Introduction and Objectives: Forensic scientists are often asked to estimate a blood alcohol concentration (BAC) based on a reported alcohol dose. Such estimates will never be accurate but as long as the dose of alcohol is fully absorbed into the total body water (TBW) and appropriate uncertainty values are applied to an individual's TBW and blood alcohol clearance rate (β_{60}), a range of BAC values within which the actual BAC is likely to lie can be calculated. ESR scientists use a calculator developed by Dr. Allan Stowell, based on published studies, to make these "forward estimations" of BAC. The calculation is based on the dose of alcohol, total metabolism time, and an estimate of TBW based on the drinker's height and weight [1, 2]. One study, to determine the reliability of such estimations, was conducted at ESR in 1998 on male subjects [3].

Methods and Materials: A similar but more recent ESR study was carried out with both males and females. It involved the collection of blood samples for analysis less than one hour after drinking stopped (mean \pm SD: 29 \pm 13 min, range 10 to 58 min). Therefore, for some subjects at least, full absorption of the alcohol dose was unlikely at the time of blood sampling. The study was designed to replicate typical social drinking. It involved 15 subjects, 6 females (mean height: 164 \pm 11 cm; mean weight: 58 \pm 11 kg) and 9 males (mean height: 182 \pm 4 cm; mean weight: 88 \pm 14 kg) who consumed alcoholic drinks of their choice over a period of 3 to 5 hours, during which they ate a three-course meal. The amounts (dose range 0.75 to 2.44g/kg of body weight) and types of alcohol consumed (beer, wine and spirits were available) were recorded for each subject, along with the time drinking started and stopped. A venous blood sample was taken after drinking stopped. The delay between the time of the last drink and the time of blood sampling could not be standardized due to the presence of only one phlebotomist and the inability of intoxicated people to follow instructions they had agreed to while sober.

Results and Conclusions: Estimates of BAC at the time of blood sampling were made assuming all β_{60} values were within the range of 10 - 25 mg/100mL/hr, and all TBW estimates [1,2] had a standard uncertainty of \pm 10%. Therefore, the estimated BAC ranges (and 95% confidence intervals) take into account two of the major sources of uncertainty but not that associated with alcohol absorption. In spite of this, the BAC results determined by gas chromatography were all within the estimated ranges and had an average deviation from the midpoint of the 95% confidence interval of + 13%. No trends were observed between these deviations and the delay between cessation of drinking and blood sampling.

References:

1. Watson PE, Watson ID, Batt RD. Prediction of blood alcohol concentrations in human subjects. *J Stud Alcohol* 1981;42(7):547-56.
2. Seidl S, Jensen U, Alt A. The calculation of blood ethanol concentrations in males and females. *Int J Legal Med.* 2000;114:71-77.
3. Stowell AR, Stowell LI. Estimation of blood alcohol concentrations after social drinking. *J Forensic Sci.* 1998;43(1):14-21.

Key Words: Social Drinking, Blood Alcohol Estimation, Incomplete Absorption

Comparison of Different Markers of Chronic Alcohol Abuse in the Assessment of Driving FitnessVala Poloni¹, Mario Spinelli¹, Alberto Salomone², Azeem M. Khan³, **Aldo Polettini***³¹Provincial Medical Commission for Driving Licenses, ASL CN1, Cuneo; ²Regional Antidoping Center "A. Bertinaria", Turin; ³Department of Public Health & Community Medicine, University of Verona, Italy

Objectives: The availability of different Markers of Chronic Alcohol Abuse (MCAA) in a group of 259 subjects submitted to the assessment of driving fitness at the Provincial Medical Commission for Driving Licenses of Cuneo, Piedmont, Italy from June 2009 to January 2010 offered the opportunity to compare performance with regards to an alcoholologist diagnosis ("abstaining or moderate use", "chronic abuse"), and to the conclusive diagnosis of driving fitness ("temporary fit" or "temporary unfit for driving").

Methods and Materials: Together with self reported anagraphic and anamnestic data, subjects underwent a clinical examination, and provided a blood sample and a proximal 3-cm hair segment for the determination of Aspartate Transaminase (AST), Alanine Transaminase (ALT), Mean Corpuscular Volume (MCV), γ -Glutamyl Transferase (γ GT), Carbohydrate Deficient Transferrin in serum (CDT), and ethyl glucuronide in hair (HEtG). AST, ALT, MCV, γ GT were determined by routine automated techniques; %CDT (as relative percentage of asialo-, monosialo-, and disialo-transferrin isoforms) was determined using the HPLC Reagent Kit BioRad[®] (Munich, Germany); HEtG was determined using a validated HPLC-MS-MS technique operating in SRM mode (LLOQ, 10 pg/mg). The alcoholologist determination and the driving fitness determination were considered references for comparison. For each MCAA, the Receiver Operating Characteristic (ROC) Curve was constructed by plotting the rate of true positives (Sensitivity, SE) vs. rate of false positives (1-Specificity, SP) while increasing the cut-off, and the corresponding area under curve (AUC) was calculated.

Results: The following AUCs were calculated: AST, 0.529; ALT, 0.623, γ GT, 0.736; MCV, 0.833; CDT, 0.815; HEtG, 0.982. No relevant modification of the AUC (0.974) was observed for HEtG after removing pubic hair cases (n=12). With respect to the driving fitness diagnosis, the following AUCs were calculated: AST, 0.455; ALT, 0.522, γ GT, 0.591; MCV, 0.666; CDT, 0.592; HEtG, 0.877 (0.958 after removing pubic hair cases).

Conclusions: As expected, all MCAA performed better when compared to the alcoholologist diagnosis than to the driving fitness evaluation that, together with alcohol abuse, may involve other criteria. For example, subjects with driving licences for trucks and other heavy vehicles were found to have a significantly higher probability to be assessed as unfit, indicating that the Medical Commission tends to evaluate such subjects more carefully, owing likely to the increased hazard for public safety. HEtG was the better performing marker both when compared to alcoholologist diagnosis and to driving fitness evaluation. The application of a cut-off of 30 pg/mg eliminated false positives compared to the alcoholologist evaluation (SP=1) with a SE as high as 0.88 (both including or excluding pubic hair cases).

Key Words: Chronic Alcohol Abuse, Driving Fitness, Ethyl Glucuronide, Hair Analysis

Liquid Chromatography-Mass Spectrometry Measurement of the Alcohol Biomarker Phosphatidylethanol (PEth) in Blood**Anders Helander**^{1,*}, Yufang Zheng¹ and Olof Beck²¹Alcohol Laboratory, Department of Laboratory Medicine, Karolinska Institutet, Stockholm, Sweden; ²Department of Medicine, Karolinska Institutet, Stockholm, Sweden

Objectives: Phosphatidylethanol (PEth) are phospholipids formed from ethanol and phosphatidylcholine by action of the enzyme phospholipase D. Whole blood PEth is employed as an alcohol biomarker and can be detected for up to 3–4 weeks after cessation of drinking. The aim of this study was to improve an LC-MS(/MS) method for measurement of PEth (Clin Chem 2009;55:1395) to make it suitable for routine use.

Methods and Materials: Whole blood samples were obtained from blood donors and from clinical samples with unknown alcohol histories. A total lipid extract was separated on a C4 column, followed by electrospray ionization (ESI)-MS detection of nine deprotonated PEth molecules in selected ion monitoring (SIM) mode, or ESI-MS/MS detection of the major product ions (i.e. fatty acids) by selected reaction monitoring (SRM). The detection limit (LOD) of the method was <0.01 µmol/L. In routine use, the quantitation limit (LLOQ) for total PEth was set at 0.10 µmol/L.

Results: Individual calibration curves were required for MS quantitation of some PEth forms. In MS/MS analysis, penta-deuterated analogues were preferable over phosphatidylpropanol as the internal standard. PEth-16:0/18:1 (1-palmitoyl-2-oleoyl-sn-glycero-3-phosphoethanol) was the single most sensitive molecular form and was detected (≥ 0.01 µmol/L) in all 211 specimens with a total PEth concentration of 0.1–20 µmol/L (100% sensitivity). PEth-16:0/18:1 and 16:0/18:2 (1-palmitoyl-2-linoleoyl-sn-glycero-3-phosphoethanol) accounted for around 36% and 26%, respectively, of the total amount and was correlated with total PEth ($R^2 = 0.922$ – 0.940). An improved correlation was obtained for the sum of these two forms ($R^2 = 0.994$).

Conclusions: The LC-ESI-MS(/MS) method allowed for qualitative and quantitative measurement of PEth in whole blood samples. The best correlation with total PEth was obtained for the sum of PEth-16:0/18:1 and 16:0/18:2. This indicates that the combined measurement of these two major PEth forms may be superior to measuring only one of them, because this strategy can compensate for the marked inter-individual variation in the blood PEth profile. Based on analysis of 200 whole blood specimens from blood donors with unknown drinking habits, 95% reference intervals were determined to be <0.70 µmol/L for total PEth, <0.20 µmol/L for PEth-16:0/18:1, and <0.18 µmol/L for PEth-16:0/18:2.

Key Words: Alcohol Biomarker; LC-MS; Phosphatidylethanol.

Detection of Plant Alkaloids in Fatalities: The Advantage of General (Non-Targeted) Screening**Simon Elliott*.**

(ROAR) Forensics Ltd, Malvern, UK

Introduction and Objectives: The use of selective ion monitoring in GC-MS and selective/multiple reaction monitoring in triple quadrupole LC-MS has enabled the analytical toxicologist to develop specific and sensitive screening methodologies. Following selection and optimization this process results in the targeted detection of a pre-determined range of drugs and metabolites. Consequently, excluded compounds are not detected. Whilst such methods typically involve a wide range of commonly encountered drugs, there are invariably occasions where toxicologically significant compounds may be present but missed. Use of general (non-targeted) screening methods by e.g. GC-MS, HPLC-DAD, LC-MS or QTOF-MS has been shown to be useful in numerous situations. In particular, the author presents examples of the detection of plant alkaloids in post mortem matrices (blood, urine and/or stomach contents) and in some expected and unexpected fatal circumstances which had a significant impact on the interpretation and investigation of the deaths.

Materials and Methods: The Yew tree (*Taxus baccata*) has been used for both medicinal and toxic purposes over thousands of years. Every part of the tree is toxic except for the berries which have laxative and diuretic properties but the seeds themselves are toxic. Despite this, Yew tree poisoning in humans is rare but the toxic taxine alkaloids have been found in 4 fatalities in the last 3 years, including one road traffic incident. "Iboga" is a plant-based product used as a herbal medicine and in ritual and ceremonial instances. Found in Central Africa, it is derived from the *Tabernanthe iboga* shrub and contains the primary alkaloid, ibogaine. This is also metabolized to produce pharmacologically active noribogaine. Reported deaths are rare but such compounds have been detected in 2 fatalities. *Gelsemium sempervirens* is a plant species native to North America and can be referred to as yellow jasmine. The main alkaloid is gelsemine and is present in all parts of the plant but again there are few well documented cases of *Gelsemium* poisoning. As part of routine general screening protocols using HPLC-DAD and hybrid linear ion-trap LC-MS, gelsemine alkaloid was found in 1 fatality where use of a herbal substance purchased from the Internet was suspected. Identification for all the above alkaloids was based on comparison with analytical databases, published data or analysis of reference material or the plant itself.

Results and Conclusions: Uncommon compounds such as plant alkaloids are unlikely to be included in laboratory targeted screening but detection would be important to the case. Furthermore, other uncommon or not previously encountered drugs would also not be detected if a targeted system is the sole method of screening employed. For example, this is particularly important for existing and future detection of "designer drugs" (such as cathinones, desoxypipradrol, piperazines, etc). It is therefore recommended that a general (non-targeted) technique is included in any analytical screening strategy.

Key Words: Screening, Alkaloids, LC-MS, HPLC-DAD

One-Year Monitoring of Nicotine Use in Sport: Frontier Between Potential Performance Enhancement and Addiction Issues**François Marclay**^{1,*}, Elia Grata¹, Laurent Perrenoud¹ and Martial Saugy¹¹Swiss Laboratory for Doping Analyses, University Center of Legal Medicine, Geneva and Lausanne, Centre Hospitalier Universitaire Vaudois and University of Lausanne, Ch. des Croisettes 22, 1066 Epalinges, Switzerland

Objectives: Tobacco consumption is a global epidemic responsible for a vast burden of disease. Nicotine is largely responsible for tobacco's pharmacological effects. Smokeless tobacco products are of growing popularity in sport owing to potential performance enhancing properties and absence of adverse effects on the respiratory system. Indeed, nicotine has significant positive effects on motor abilities, attention and response time, while reducing stress and anxiety (Benowitz N., *N Engl J Med* (2010) 362; 24, Heishman S. et al, *Psychopharmacology* (2010) 210:453-469). However, nicotine does not appear on the 2011 World Anti-Doping Agency (WADA) Prohibited List or Monitoring Program due in part to the lack of a comprehensive large-scale prevalence survey. Thus, this work describes a one-year monitoring study on urine specimens from professional athletes of different disciplines in 2010 and 2011.

Methods: An Ultra-High Pressure Liquid Chromatography Triple Quadrupole mass spectrometry (UHPLC-TQ-MS/MS) method for the detection and quantification of nicotine, its major metabolites (cotinine, trans-3-hydroxycotinine, nicotine-N'-oxide and cotinine-N-oxide) and minor tobacco alkaloids (anabasine, anatabine and nornicotine) was developed and validated. A simple and fast dilute-and-shoot sample treatment was performed, followed by Hydrophilic Interaction Chromatography-tandem mass spectrometry (HILIC-MS/MS) operated in positive electrospray ionization (ESI) mode with multiple reaction monitoring (MRM) data acquisition. LOD and LLOQ for all compounds of interest were 1 and 10 ng/mL, respectively.

Results: The prevalence of nicotine consumption in sport involved analysis of 2,185 in competition urine samples from 43 different sports. Concentrations of major nicotine metabolites, minor nicotine metabolites and tobacco alkaloids ranged from LLOQ to 32,223, LLOQ to 6,670 and LLOQ to 538 ng/mL, respectively. Compounds of interest were detected in trace levels (LOD < x < LLOQ) in 23.0% of urine specimens; exposure within the last three days was suggested for 18.3% of samples. We hypothesized that conservative concentration limits of 50 ng/mL for nicotine, cotinine and trans-3-hydroxycotinine and 25 ng/mL for nicotine-N'-oxide, cotinine-N-oxide, anabasine, anatabine and nornicotine) would indicate active nicotine consumption within the day of competition and/or during sport practice based on published pharmacokinetic data (Wall M. et al, *AJPH* 78:6 (1988), Benowitz N., *Epidemiol Rev* 18:2 (1996)). Employing these cutoff concentrations, a prevalence of 15.3% amongst athletes was achieved. This prevalence is lower than the worldwide smoking prevalence of 25%; however, focusing on selected sports with over 20 urine specimens provided over the testing period, indicated higher prevalence (19.0 to 55.6%) in selected sports including ice hockey, skiing, biathlon, bobsleigh, skating, football, basketball, volleyball, rugby, American football (Swiss League), wrestling and gymnastics. Considering the adverse effects of smoking on the respiratory tract and numerous detrimental health concerns for athletes, consumption of smokeless tobacco for performance enhancement may be a concern.

Conclusion: Thus, WADA and sport federations should evaluate the inclusion of nicotine on the Prohibited List and/or Monitoring Program as a potential doping agent, and also develop a more preventive approach in the fight against doping. Education on a global public health threat could be initiated.

Key Words: Nicotine; Doping Control; UHPLC

Nano Ultra-Performance Liquid Chromatography Time-of-Flight Mass Spectrometry Multi-Analyte Screening of Regulated Drugs and (Un)Known Biotoxins

Michel W.F. Nielen^{*-1,2}, Arjen Gerssen¹, Payam Aqai¹, and Willem Haasnoot¹.

¹RIKILT-Institute of Food Safety, Wageningen UR, Wageningen, The Netherlands.

²Laboratory of Organic Chemistry, Wageningen University, Wageningen, The Netherlands.

Introduction and Objectives: State-of-the-art analytical tools available for multi screening of small molecules such as drugs in analytical toxicology, doping substances in sports, and contaminants in the food chain are based on high resolution or Ultra Performance Liquid Chromatography (UPLC) coupled to Time-of-Flight mass spectrometry (TOFMS) [1,2]. This technique allows screening for a theoretically unlimited number of compounds and gives the possibilities to search the data retrospectively for new emerging substances. The next step, conversion of UPLC/TOFMS multi screening into nano formats, offers advantages related to “green analytical chemistry”, small sample size, and bioactivity-directed structure elucidation of unknowns. The latter can be accomplished either in a post-column [3] or in a pre-column mode [4] using biorecognition-based affinity extraction. In bioaffinity extraction the elution volume is typically small (<5 µl) since rather expensive bioreagents are being used. The objective of our research was two-fold: exploration of the critical issues encountered in the conversion of a UPLC/TOFMS multi drug screening application into a nano format, and secondly, demonstrating the feasibility of bioaffinity-directed identification of (un)known biotoxins not included in conventional targeted instrumental analysis approaches.

Results: Results obtained for nanoUPLC of veterinary drug residues in muscle tissue were quite encouraging; compared to conventional LC, faster separation and a 10-fold sensitivity improvement in the TOFMS detection was achieved. The main critical issue was the selection of pre-column sorbent. Using a nano electrospray QTOFMS system it was possible to run every 0.6 seconds a scan in MS and in MS^e mode. MS^e helped to distinguish between closely eluting non-steroidal anti-inflammatory drugs (NSAIDs) having the same exact mass of the precursor ion but different product ion masses, without any precursor ion selection. Following a microsphere immunoassay pre-screening and subsequent bioaffinity isolation using the same immunoaffinity beads, the feasibility of bioaffinity-directed nano UPLC/(Q)TOFMS identification was demonstrated: both a target mycotoxin and another - apparently cross-reacting - mycotoxin were successfully identified in a cereal sample. .

Conclusion: These results suggest that nano UPLC/(Q)TOFMS is a robust and more sensitive alternative in multi-drug screening for regulated as well as (un)known emerging toxic substances.

References

- [1] A. Pelander, P. Decker, C. Baessmann and I. Ojanpera, *J. Am. Soc. Mass Spectrom.*, 22 (2011) 379-385.
- [2] R.J.B. Peters, A.A.M. Stolker, J.G.J. Mol, A. Lommen, E. Lyris, Y. Angelis, A. Vonaparti, M. Stamou, C. Georgakopoulus and M.W.F. Nielen, *Trends Anal. Chem.*, 29 (2010) 1250-1268.
- [3] M.W.F. Nielen, T.F.H. Bovee, P. Rutgers, A.R.M. Hamers, J.A. van Rhijn, L.A.P. Hoogenboom, *Anal. Chem.*, 78 (2006) 424-431.
- [4] P. Aqai, J. Peters, A. Gerssen, W. Haasnoot, M.W.F. Nielen, *Anal. Bioanal. Chem.*, (2011) in press, DOI 10.1007/s00216-011-4974-7.

Key Words: Multi-Drug Screening, NanoLC/MS, Bioaffinity

The Use of Hybrid Linear Ion Trap LC-MS and UHPLC QTOF-MS in the Detection of Glucuronide Metabolites in Urine

Kerry Taylor*, Diane Cassidy and Simon Elliott
(ROAR) Forensics Ltd, Malvern, UK

Introduction and Objectives: Advances in mass spectrometry have allowed the detection of Phase II metabolites such as intact glucuronides without the need of potentially inefficient hydrolysis (i.e. removal of the glucuronic acid from the drug/drug metabolite). Many of the major prescribed and illicit drugs form glucuronides following addition of glucuronic acid to a nitrogen or an oxygen group present in the structure (i.e. forming N-glucuronide or O-glucuronide). Such metabolites are eliminated in the urine and may remain detectable for an extended period of time after the parent drug or primary metabolites have become undetectable. The aim of this work was to apply advanced LC-MS techniques to the detection of known and novel metabolites in routine casework.

Materials and Methods: Following solid phase extraction (using UCT Clean Screen DAU Octyl + Benzyl Sulfonic Acid 200mg), urine (n=33) from fatalities and suspected drug facilitated sexual assault cases were analysed using an ABSciex 3200 QTRAP and an Agilent 6530 QTOF-MS, with Agilent 1200 Series HPLC and UHPLC systems, respectively. Chromatographic separation was based on a Phenomenex Gemini with ammonium formate, formic acid and acetonitrile gradient mobile phase for HPLC; and an Agilent Eclipse Plus C18 with formic acid and acetonitrile gradient mobile phase for UHPLC. General toxicology screening had identified parent drugs and Phase I metabolites. Coupled with prescription information, this provided potential target glucuronide metabolites. Glucuronides were detected by targeted multiple reaction monitoring (MRM) screening and by neutral-loss of 176 (protonated molecular mass of glucuronic acid) using the QTRAP with information dependent enhanced product ion scans. For QTOF-MS, non-targeted screening of the urine with post-run accurate mass neutral loss data interrogation (176.1321) was used followed by re-injection of the extract with non-targeted automated MS-MS fragmentation. A non-targeted approach afforded the potential to detect a large number of drug types.

Results and Conclusions: Due to the unavailability of certified reference material for the vast majority of glucuronides, identification was based on the fragmentation of the glucuronide. Depending on the conditions used, this was found to form either a) an accurate mass parent drug ion or b) ion fragments comparable to the mass spectral fragmentation of the parent drug or drug metabolite. Both allowed matching against mass spectral libraries. This methodology was demonstrated by the analysis of temazepam glucuronide and oxazepam glucuronide certified reference material (Phase II metabolites of e.g. diazepam and temazepam). The limit of detection for both glucuronides was determined to be 250 mg/L using HPLC-MS-MS (QTRAP) and 100 mg/L using UHPLC-QTOF-MS (accurate mass neutral loss). The mean recovery at 1000 mg/L for both glucuronides was 46%. The corresponding mean matrix effect was less than 2% suppression to 30% enhancement depending on the analyte and techniques used (i.e. HPLC-MS-MS or UHPLC-QTOF-MS). Analysis of casework detected numerous glucuronide metabolites, some of which are seemingly yet to be described in the toxicological literature; for example, omeprazole glucuronide. Furthermore, more common and predicted glucuronides have been found which supported initial toxicology analysis and the prescription history, as well as cases where such metabolites were found in the urine days after purported last use. These include the glucuronide conjugates of citalopram, dihydrocodeine, morphine, amitriptyline, lamotrigine, propranolol and venlafaxine. The development of screening methods for these metabolites could be applied in many different forensic applications including supporting drug history and potential compliance, as well as increasing the detection window for drugs that may be used in drug facilitated crime.

Key Words: Glucuronide Metabolites, QTOF-MS, LC-MS, DFSA

Semi-Quantitative Analysis in General Unknown Screening by Liquid Chromatography - Hybrid Quadrupole Time-of-Flight Mass Spectrometry (LC-QTOF-MS)

Sebastian Broecker*, Fritz Pragst, Gregor Kopf, Catharina Seidel, and Sieglinde Herre
Institute of Legal Medicine, University Hospital Charité Berlin, Germany.

Objectives: In toxicological general unknown screening of human specimens, qualitative identification and quantitative concentration are important for interpretation. In this study, it is shown that liquid chromatography-hybrid quadrupole time-of-flight mass spectrometry (LC-QTOF-MS) in combination with large qualitative and quantitative databases of toxic compounds is a suitable technique to fulfill these requirements.

Materials and Methods: In extension of substance identification using accurate mass database and spectra library of toxic compounds [1], the retention times and peak areas of more than 2,000 substances were measured by LC-QTOF-MS using an Agilent 6530 instrument under standardized conditions (column: Poroshell 120 EC-C18, 2.1x100mm, 2.7 μ m; gradient elution: NH₄Ac/H₂O and methanol; flow rate 0.4mL/min, positive ESI) by injection of 100 pg substance with 100pg of 32 deuterated standards with retention times evenly spread over the run time. Protonated species and adducts with Na⁺, K⁺ or NH₄⁺ were separately recorded but can be used also in combination. All retention times and peak areas were stored in a database "LC-TOF-QUANT". In practical application, the sample preparation (protein precipitation, extraction of hair) was performed after addition of all 32 internal standards and the extracts were measured by LC-QTOF-MS in data dependent acquisition mode under the same standard conditions. The analytical file was submitted to substance identification by the corresponding software tools (molecular formula from accurate mass and isotope pattern, identification by search in accurate mass CID spectra library, comparison of retention time). For an identified peak, an in-house software tool "Estimate Concentration" selects a certain number (e.g. five) of nearby eluting deuterated standards, extracts the corresponding standard peak areas of the analyte and selected deuterated standards from LC-TOF-QUANT and calculates the concentrations from the peak area ratios of analyte and deuterated standards in the analysis file in LC-TOF-QUANT and the sample concentration of the deuterated standard. The results are tested for outliers that are omitted and the mean concentration and standard deviation are calculated.

Results: The method was tested on spiked and authentic blood and hair samples. For five different blood samples spiked with 31 illegal and therapeutic drugs at concentrations 5, 25, 100 and 500 ng/mL, the measured and spiked concentrations were in good agreement with a standard deviation between 8 and 30%. For hair samples spiked with 0.05, 0.25, 1.0 and 5.0 ng/mg of 31 drugs, the agreement was even better, with standard deviations between 5 and 15%. Furthermore, the results from more than 25 authentic post-mortem blood samples agreed, with concentration variation ranging from -33 and +50 % with the quantitative data from HPLC-DAD and GC-MS.

Conclusion: The developed method appears to be a useful strategy for the fast approximate estimation of concentrations when reference substances are not available. Investigations about the applicability to a broader variety of substances and the use of different instruments are in progress.

References:

1. S. Broecker, S. Herre, B. Wüst, J. Zweigenbaum, F. Pragst, *Anal Bioanal Chem.* 400 (2011) 101-117.

Key Words: Accurate Mass, General Unknown, Liquid Chromatography-Mass Spectrometry, Time-of-Flight Mass Spectrometry

MALDI-Mass Spectrometric Imaging – Analysis of Cocaine and Metabolites in a Single HairTiffany Porta¹, Chantal Grivet¹, Emmanuel Varesio¹, Gerard Hopfgartner¹ and **Thomas Kraemer**^{*,2}¹School of Pharmaceutical Sciences, Life Sciences Mass Spectrometry, University of Geneva, Geneva, Switzerland;²Institute of Legal Medicine, University of Zurich, Zurich, Switzerland.

Objective: Matrix-assisted laser desorption/ionization mass spectrometric imaging (MALDI-MSI) was used to monitor abuse of cocaine by detection of the parent compound and its metabolites in intact single hair samples.

Methods: Acquisitions were performed on a prototype MALDI triple quadrupole linear ion trap fitted with a high repetition rate laser (1 kHz). In contrast to standard hair analysis, sample preparation is simple (washing, fixing the single hair on a MALDI plate and spraying with α -cyano-4-hydroxycinnamic acid (CHCA) or 4-chloro- α -cyano-cinnamic acid (Cl-CCA) as MALDI matrix). Screening and relative quantitation was performed in the selected reaction monitoring (SRM) mode (COC 304.2/182.1; COC-d3 307.2/185.1; BZE 290.2/168.1; BZE-d3 293.1/171.1). Sensitive confirmation was achieved with both MS/MS (enhanced product ion) and MS³ experiments (n=8). Results were compared with routine LC-MS results (analysis of segments of a bundle of hair with the circumference of a pencil; LC-SRM/MS on a Qtrap 3200; ESI mode; gradient elution on a Synergi Polar-RP (150 x 2.0 mm, 4 μ m / 80A); mobile phase: ammonium formate buffer pH 3.5 with formic acid and acetonitrile containing 1 mM ammonium formate and 1 mM formic acid).

Results: A simple and sensitive method for the simultaneous screening and relative quantitation of cocaine and metabolites (benzoylecgonine, cocaethylene and norcocaine) in intact single hair was developed. MALDI-MSI allowed obtaining a spatial resolution of 1 mm and thus the chronological information about cocaine consumption over several months could be monitored. High sensitivity of MALDI-MSI (SRM) allowed the detection of drugs in pg amounts. Sensitive confirmatory analyses with both MS/MS and MS³ experiments performed directly on intact hair samples were also possible. Cocaine and metabolites could be detected in hair samples of 9 different individuals using our novel MALDI LC-MS method in accordance with routine LC-MS analytical results employing 500 pg/mg cut-off concentration.

Conclusion: MALDI-MSI has proven to be a technique for analysis of cocaine and metabolites in a single hair. The study should be seen as a proof of concept. More studies are necessary to show its usefulness for other drugs.

Key Words: MALDI-MSI, Cocaine, Hair Analysis

Identification of the Major Metabolites of Six Synthetic Cannabinoids Present in “Herbal Mixtures” in Human Urine Samples Using LC-MS/MS Techniques**Melanie Hutter***¹, Stefan Kneisel¹, Sebastian Broecker², and Volker Auwärter¹¹Institute of Forensic Medicine, University Medical Center Freiburg, Germany; ²Institute of Forensic Medicine, Charité Berlin, Germany

Objectives: Since the appearance of “Spice” in 2008, a multitude of similar products have gained popularity. Several methods for the analysis of synthetic cannabinoids in blood or serum have been published recently; however, little is known about their metabolism. Our aim was to identify the main metabolites of the most common synthetic cannabinoids and build a screening method for urine samples.

Materials and Methods: Urine samples were collected from patients in forensic psychiatric facilities. After the determination of synthetic cannabinoids in serum samples, the respective urine samples were screened for major metabolites of each synthetic cannabinoid using liquid chromatography-tandem mass spectrometry (LC-MS/MS) with electrospray ionisation (ESI). At least five urine samples per synthetic cannabinoid were investigated. For analysis of the samples, an alkaline liquid-liquid extraction method after hydrolysis using β -glucuronidase was applied. The liquid chromatography-tandem mass spectrometry (LC-MS/MS) system consisted of a QTrap 4000 triple-quadrupole linear ion trap mass-spectrometer fitted with a TurbolonSpray interface and a Shimadzu Prominence HPLC system. Separation was achieved on a Luna C18 column (150 mm \times 2 mm, 5 μ m particle size) with an equivalent guard column (4 mm \times 2 mm) and gradient elution using solvents A (water with 0.2% formic acid and 2 mmol/L ammonium formate) and B (methanol). A post-column addition of isopropanol at a flow rate of 0.2 mL/min enhanced sensitivity. The injection volume was 20 μ L. Further characterization of the main metabolites was performed by means of high resolution tandem mass spectrometry (HR-MS/MS) on an Agilent 6530 Accurate-Mass Q-TOF LC/MS instrument with the same LC conditions.

Results: Three main metabolites for each of the following synthetic cannabinoids were identified by their EPI spectra and accurate mass: JWH 018, JWH 073, JWH 081, JWH 122, JWH 210 and JWH 250. The major metabolic pathway indicated monohydroxylation at either the alkyl side chain naphthyl or indole moiety. Additionally for some analytes, side metabolites with carboxylated alkyl chains were also identified.

Conclusion: As expected for all aminoalkylindole-derivatives under investigation, the main metabolites found in urine are built in an analogous manner. Due to the constantly changing composition of “herbal mixtures” the continuous inclusion of metabolites of new compounds into analytical methods is needed to facilitate effective abstinence control.

Key Words: Synthetic Cannabinoids, Metabolites, LC-MS/MS

'Spice' in Oral Fluid: LC-MS/MS Identification of Active Compounds

Cynthia Coulter*, Margaux Garnier, James Tuyay, Jonathan Orbita, Jr., Christine Moore
Immunalysis Corporation, Pomona, CA, USA

Introduction and Objectives: In March 2011, the U.S. DEA used its emergency scheduling authority to control five chemicals, JWH-018, JWH-073, JWH-200, CP-47,497, and cannabicyclohexanol (CP-47,497 C8), often referred to as "spice", K2, or "synthetic cannabinoids" due to their reported cannabis-like effects. In addition, HU-210 and JWH-250 have been reported in various 'Spice' like materials. The objective was to develop a procedure for the simultaneous determination of these compounds in human oral fluid using LC-MS/MS and apply it to authentic specimens.

Methods: An analytical method was developed for extraction of several 'Spice' compounds from Quantisal™ devices, using solid-phase columns and LC-MS/MS. The method monitored two transitions for each compound and required the qualifier ratio to be within 20% of that established by the calibration standard to be considered as positive. The linear range of the assay was 0.5 -100ug/L. The intra-day imprecision for all drugs was <6% at 4 and 40ug/L (n=6); inter-day <10% at both concentrations (n=30). Oral fluid specimens were collected from two individuals who had purchased the "herbal highs" while still legally available in the USA. Both individuals were naïve to synthetic marijuana. Subject #1 smoked 50mg of "Blueberry Posh" and subject #2 smoked 50mg of "Black Mamba". Both Spice brands were confirmed by LC-MS/MS and GC/MS to contain JWH-018 only. Using a Quantisal™ oral fluid collection device, specimens were collected prior to the start of the experiment, then at various time points after smoking. Subject 1 gave specimens after 20min, 40min, 1 hr, 2 hrs and 12 hrs; Subject 2 gave samples after 20 min, 40min, 1 hr, 5 hrs and 12 hrs.

Results: Both subjects were confirmed negative for "spice" at time 0 and both participated in only one smoking session. Subject 1 reached a peak concentration of 35ug/L of JWH-018 at 20min. Concentrations dropped to 5ug/L by 2 hours and JWH-018 was detected at 0.5ug/L at 12 hours. Subject 2 reached a peak concentration of 5ug/L at 20min with JWH-018 being detectable for 5 hours. Sample stability was performed after 1 month with samples stored at 4°C not in their original collection device. The re-analysis gave similar results.

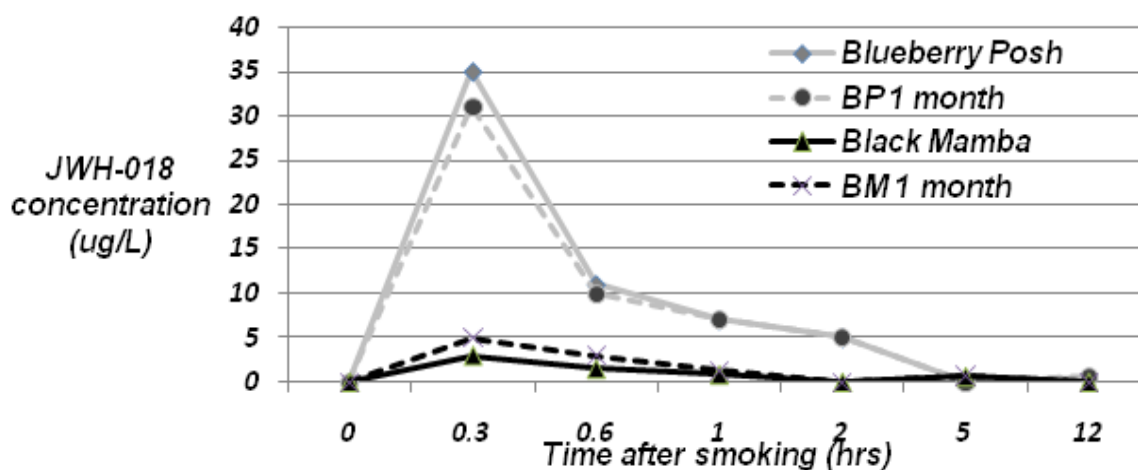

Conclusion: An analytical method for the determination of "Spice" compounds in oral fluid has been developed and applied to authentic specimens. JWH-018 was detectable for 5 hours in one user and 12 hrs in a second following one smoking session of commercial products.

Key Words: Spice; Oral Fluid; LC-MS/MS

Determination of a Synthetic Cannabinoid, JWH-018, and its Metabolites in Rat Urine and Hair Samples Using UPLC-MS/MS

Ruri Kikura-Hanajiri^{*1}, Maiko Kawamura¹, Takuji Shoda¹, Kiyoshi Fukuhara¹, Haruhiro Okuda¹, Yukihiro Goda¹

¹National Institute of Health Sciences, Tokyo, Japan

Objectives: In recent years, herbal products containing synthetic cannabinoids or “Spice” have been widespread in global illegal drug markets. In this study, a rapid and sensitive determination method for a typical synthetic cannabinoid, JWH-018, and its metabolites in urine and hair samples was investigated using UPLC-MS/MS. Moreover, the optimum method was applied to determine the target metabolites in biological samples of rats administered JWH-018.

Materials and Methods: 1) Target metabolites: Eleven potential metabolites of JWH-018; alkylcarboxy (M1), terminal alkylhydroxy (M2), 2-, 4-, 5-, 6-, 7-indolehydroxyl (M3-M7) metabolites (purchased from Cayman) and N-dealkylated 4-, 5-, 6-, 7- indolehydroxyl (M8-M11) metabolites (synthesized in our laboratory) were focused upon in this study. 2) UPLC-MS/MS method: Chromatographic separation was performed in a gradient mode (0.1% formic acid - acetonitrile) on an ACQUITY UPLC BEH C18 column (2.1×100 mm, 1.7 μm). MRM was used in the positive mode of an ESI-MS/MS for the quantitative analysis. 3) Extraction optimization: After enzymatic hydrolysis, the recoveries of JWH-018 and the potential metabolites from spiked rat standard urine samples, using seven liquid-liquid extraction and two solid-phase extraction methods, were compared. Additionally, the efficacy of three extraction methods (acid-methanol extraction, enzymatic digestion and alkali hydrolysis) on the recoveries of the analytes from rat hair samples was investigated. 4) Animal experiments: After the administration of JWH-018 to pigmented hairy male Dark Agouti (DA) rats (5 mg/kg/day, i.p., 10 days), the parent compound and its metabolites in the rat urine and hair were determined using UPLC-MS/MS.

Results and Conclusion: The complete separation of JWH-018 and the 11 potential metabolites was achieved on a UPLC column within 13 min. The liquid-liquid extractions using hexane/ethyl acetate (1:2), hexane/dichloromethane (2:1), t-butyl methyl ether or ethyl acetate were effective at pH 5-9 for the extraction of JWH-018 and the metabolites from the rat standard urine samples. After alkali hydrolysis of hair samples, liquid-liquid extraction using t-butyl methyl ether was superior to other methods. After administration of JWH-018 to male rats, M10, M11, M6, M1 and M2 were the primary analytes detected in urine samples (0-120 hr), while JWH-018 was detected with only a trace level up to 24 hr after administration. However, JWH-018 was found in relatively large amounts (2.0 ng/mg) in the rat hair samples. In the hair, M1 (7.05 ng/mg) and M10 (1.17 ng/mg) were also detected.

Key Words: JWH-018, Metabolites, Hair Samples

Application of Liquid Chromatography-Tandem Mass Spectrometry for Identification and Quantification of 'Legal Highs' Active Components' in Blood

Bogdan Tokarczyk^{*1}, Piotr Adamowicz¹, Markus Slopianka²

¹Institute of Forensic Research, Krakow, Poland; ²Hochschule Fresenius, Idstein, Germany

Introduction and Objectives: The market for 'legal highs' or 'party pills' expanded in Poland over the last two years. A number of drugs with similar stimulant effects were legally sold in herbal shops or online as e.g. 'bath salts'. These 'legal highs' are mainly cathinone and piperazine derivatives, as well as synthetic cannabinoids. Serious effects, including deaths, are caused by intake of 'legal highs'. Analytical procedures are necessary for identification and quantification of these drugs for clinical and forensic toxicology purposes. The goal of this study was to develop a LC-MS/MS method for determination of components of 'legal highs' and their metabolites in whole blood.

Materials and Methods: The components of 'legal highs' and their metabolites were isolated from 0.2 mL blood using acetonitrile (0.6 mL) precipitation. Mephedrone-D3 and JWH-18-D9 were added as internal standards. The organic layer was evaporated and reconstituted in 100 μ L of water. The components were separated on a Zorbax SB-C18 (50x2.1mm) column using gradient elution of 0.1% (v/v) formic acid in water and acetonitrile. The target components were identified and quantified using multiple reaction monitoring (MRM) mode. The precursor ions and three fragment ions for each compound were selected as qualifiers and quantifiers.

Results and Conclusions: The procedure allowed determination of the 40 components: CP, CP55,949, CP80633, 2-CB, 2-DPMP, AM-694, bupropion, butylone, BZP, dimethyltryptamine, diethylpropion, ephedrone, ethylone, ethcathinone, HU-308, JWH-015, JWH-018, JWH-018 5-hydroxyindole metabolite, JWH-018 N-(5-hydroxypentyl) metabolite, JWH-019, JWH-073, JWH-073 5-hydroxyindole metabolite, JWH-073N(4-hydroxybutyl) metabolite, JWH-200, JWH-250, JWH-398, JWH-251, mCPP+pCPP, MDAI, MDPV, MeBP, MeOPP, MePP, mephedrone, methedron, methylone, N-(2,3-dichlorophenyl)piperazine, naphyrone, PCP, TFMPP. The assay was found to be selective for all tested compounds apart from mCPP and pCPP, which could not be separated at the presented experimental conditions. No interfering peaks were observed in the supernatant of ten different blank whole blood samples. Interferences with common drugs typically taken in combination were tested. The assay was found to be linear from 1 to 100 ng/mL. The LODs (S/N \geq 3) and LOQs (S/N \geq 10) were from 0.1 to 8.5 ng/mL and from 1 to 10 ng/mL, respectively (no weighting). Within-day, between day and total imprecision were within required limits of \leq 15% RSD. Accuracy data also were within the acceptance interval of \pm 15% (\pm 20% at the LOQ) of expected concentrations. Recovery, process efficiency and matrix effects were studied according to the simplified approach described by Matuszewski et al. Analytes were stable in processed samples when frozen for $>$ 48 h.

The LC-MS/MS method has proven to be appropriate for identification and quantification of "legal highs" components' in whole blood.

Key Words: 'Legal highs', Drug Screening, LC-MS/MS

Determination of 'Spice' Cannabinoids in Serum and Hair by Liquid Chromatography-Tandem Mass Spectrometry

M. A. Neukamm*¹, H. Sachs², T. Mürdter³, S. Kneisel¹ and M. Hutter¹

¹Institute of Forensic Medicine, University Medical Center, Freiburg, Germany; ²Forensic Toxicology Centre, Munich, Germany; ³Dr. Margarete Fischer-Bosch-Institute of Clinical Pharmacology and University Tübingen, Stuttgart, Germany.

Introduction and Objectives: 'Spice' and similar products are labelled as herbal mixtures with "intended use" as incense or plant growth modulators. However, consumers that smoked the mixtures became intoxicated. Herbal mixtures of the 'Spice'-type can contain a variety of synthetic cannabinoids including aminoalkylindoles. To prove a previous consumption of 'Spice', an analytical method to determine these psychoactive substances in blood or hair was established.

Materials and Methods: The synthetic cannabinoids (JWH-015, JWH-018, JWH-073, JWH-081, JWH-122, JWH-200, JWH-210, JWH-250 and CP 47,497-C8-homologue) were extracted from 50 mg hair by ultrasonification in methanol. For the detection of the synthetic cannabinoids in serum, a fully automated SPE procedure was applied: After addition of the internal standard d7-JWH018, the diluted sample was loaded on a C18 cartridge, washed with 0.1M acetic acid followed by 40% acetonitrile and eluted with acetonitrile. Extracts from serum and hair were analysed on a LC-MS/MS-system comprised of a Waters Alliance 2795 HPLC and a Micromass Quattro micro API Triple-quadrupole operated in positive electrospray mode. Two transitions in 'multiple reaction monitoring' mode and the retention time provided unambiguous identification of each substance.

Results and Conclusion: The synthetic cannabinoids noted above were determined by the reported method in serum and hair samples received from March 2009 to March 2011. 85 serum and 27 of 43 hair samples from alleged 'Spice' consumers tested positive for one or more of these synthetic cannabinoids. The highest concentration of JWH018 was 68 ng/mL in serum and 119 pg/mg in hair. The limit of detection and limit of quantification for JWH018 in serum were 0.2 ng/mL and 0.6 ng/mL respectively. The LOD and LOQ in hair were 0.26 pg/mg and 0.91 pg/mg. The synthetic cannabinoids in 'Spice' and similar products were successfully determined in serum and hair by LC-MS/MS in forensic cases. This determination of psychoactive Spice ingredients presents the basis for the evaluation of the influence of a drug or for the assessment of abstinence from drugs.

Key Words: Synthetic Cannabinoids, LC-MS/MS, Hair

Quantitative Analysis of Synthetic Cannabinoids JWH018, JWH073 and JWH250 in Routine Oral Fluid Specimens

Sumandeep Rana*, Tara Brunson and Wayne B. Ross
Redwood Toxicology Laboratory, Santa Rosa, CA 95403

Introduction: Redwood Toxicology Laboratory has tested for synthetic cannabinoids JWH018, JWH073 and their metabolites in urine since July 2010 and has analyzed over 50,000 specimens with an overall positivity of 18%. The main challenge testing programs encounter is the lack of information about elimination times following chronic use, thus, it is not always possible to distinguish continued elimination from renewed exposure. Oral fluid is an ideal matrix to identify new use, since the window of detection of drugs in oral fluid is generally 24-48 hrs and can be a useful tool for toxicologists. In addition, parent compounds are detected in oral fluid, and hence, it is easy to develop tests to keep up with the ever-changing formulations of designer drug-laced products. In this study, we applied a fully validated LC/MS/MS method for quantitative analysis of JWH 018, JWH 073 and JWH 250 in more than 600 authentic oral fluid specimens to determine positivity rate and concentrations of these drugs in a large pool of positive specimens.

Methods: The Quantisal collection device was used for specimen collection. Extensive extraction efficiency, stability (room temperature, 4^oC and -20^oC) and matrix effect studies were completed as part of LC/MS/MS method validation. Chromatographic separation was achieved on a Pinnacle DB biphenyl, 5 μ x 50mm x 2.1mm column. The mobile phases were 0.1% formic acid with 2mM ammonium formate and 0.1% formic acid with 2mM ammonium formate in acetonitrile. The gradient started at 10% organic mobile phase and increased to 90% organic in 8 min, held for two min and then reduced to the original condition of 10% organic. Sample volume was 20 μ L with a flow rate of 0.5 mL/min. The mass spectrometer was operated in MRM mode. Two ion transitions were monitored for each analyte and one ion transition was monitored for each internal standard. Limits of detection and quantification of the method were 0.1 and 0.25 ng/mL, respectively. The fully validated method was applied to 679 authentic oral fluid specimens.

Results: Extraction efficiency of all three analytes was >75% and the drugs were stable in the collection device for 15 days at refrigerated temperatures. Of 679 specimens analyzed, 103 (15%) were positive. The most frequently found analyte, JWH018 was detected in 90 (87%) specimens either alone (57%), in combination with JWH250 (19%), JWH073 (7%) or both JWH250 and JWH073 (4%). The concentrations of JWH018 ranged from 0.25 to 539 ng/mL. JWH 250 alone was in 12.6% specimens with concentration ranging from 0.25 to 250ng/mL. JWH073 was always detected in combination with JWH018 or JWH250 and never alone with highest JWH073 concentration being 187 ng/mL.

Conclusions: Routine analysis of human oral fluid for “Herbal High” products containing JWH018, JWH073 and JWH250 was successfully implemented with an overall positivity rate of 15%. Since parent compounds are found in oral fluid, the testing menu can be expanded with relative ease to keep up with the ever-changing designer drug products. Most of the positives (>70%) for all three drugs have concentrations below 10 ng/mL.

Key Words: Synthetic Cannabinoids, Oral Fluid, LCMSMS

Case Report: Synthetic Cannabinoid JWH-175, MDEA and MDA Involved Death in San Francisco

Ann M. Gordon^{1,*}, Ray R. Gerona², Judy Melinek¹, Alan H.B. Wu², Amy P. Hart¹, and Nikolas P. Lemos.^{1,3}

¹Office of the Chief Medical Examiner, City and County of San Francisco, 850 Bryant Street, San Francisco, CA 94103, USA; ²Clinical Chemistry Laboratory, San Francisco General Hospital & Trauma Center, San Francisco, CA 94110, USA;

³Department of Laboratory Medicine, School of Medicine, The University of California, San Francisco, CA 94143, USA

Introduction: Synthetic cannabinoid use is on the rise in the US and Europe with anecdotal reports of adverse reactions, including death. More than 400 synthetic cannabinoids exist, many of which are sold as incense with “not for human consumption” instructions and Internet sites advocating use as a legal alternative to marijuana. Legislative efforts to ban these substances in the US and Europe are hampered by emergence of new analogs and homologs. JWH-175 (a naphthylmethylindole) use has not been reported, to date, but is specifically banned in some European countries. We report here the death of a young woman following the unknowing ingestion of JWH-175.

Case History: A 31 year old, white female ingested a "pot brownie" stored in the refrigerator for several months. 45 min later, she began to experience profound adverse effects, and expressed concerns that the brownie was “laced” with other drugs. She stated she wanted to go outside and jump off the balcony. She was described as drowsy, woozy and disoriented with her eyes rolling back in her head. Despite efforts to intervene, 3 h after ingestion, she fell or jumped off the balcony to her death. She suffered subdural hematoma, pelvic fracture, liver laceration, facial fractures, and a compound elbow fracture and expired 9 days later. The family contacted the purveyor of the marijuana brownie who eventually admitted she added “Spice” purchased on the Internet, but denied adding other drugs.

Materials and Methods: Due to the delayed death, postmortem specimens were not analyzed but one admission serum was tested for ethanol, common drugs of abuse and other compounds. The semi-quantitative drugs of abuse serum panel was performed on a liquid chromatograph-time-of-flight mass spectrometer (TOF LC-MS, Agilent 6230), coupled to an Agilent 1260 LC (Agilent Eclipse C18 column (1.8 μ m, 2.1mm x 100mm). Sample preparation included protein precipitation in 95:5 (v/v) acetonitrile: methanol, followed by positive and negative electrospray ionization mass spectrometry. Agilent MassHunter Identification and Quantification Analysis identified positive matches with the following criteria: retention time match of ≤ 0.15 min and mass accuracy error ≤ 10 ppm. Quantification was done with a five-point calibration curve. The drugs of abuse panel requires 100-2500 μ L of serum and tests for 214 drugs. The patient’s specimen was also subjected to the synthetic cannabinoid panel, screening for more than a dozen JWH compounds and homologs. The limits of detection for both assays ranged from 1 to 100 ng/mL, with linearity from 500 – 5000 ng/mL.

Results: At autopsy, the subject showed evidence of blunt force injuries consistent with a 3-story fall and subsequent medical intervention. The toxicology screen on the antemortem serum specimen included 0.21 mg/L 3,4-Methylenedioxyethylamphetamine (MDEA) and 0.11 mg/L 3,4-Methylenedioxyamphetamine (MDA) and JWH-175. No quantitative standard for JWH-175 was available. Acetaminophen and lidocaine were also detected but were considered incidental findings.

Conclusions: This was the first JWH-175 human or plant case. Similar to other case reports involving new designer drugs, JWH-175 was not the direct cause of death, since the decedent died as a result of blunt force injuries. There has been some suggestion that adverse effects from synthetic cannabinoid use are more frequent in the inexperienced marijuana user, similar to this case. The mixed intoxication reported in this case study, could assist the interpretation of future cases involving JWH-175 with or without the presence of other psychoactive compounds.

Key Words: JWH-175, Synthetic Cannabinoid (Spice, K2), Serum, TOF-LC-MS

LC-ESI-MS/MS Analysis of Synthetic Cannabinoids in Serum: Evaluation on the Spectrum and Long-Term Detectability of Compounds from 900 Forensic & Clinical Specimens**Stefan Kneisel*** and Volker Auwärter

Institute of Forensic Medicine, University Medical Center Freiburg, Germany

Objectives: Due to their easy availability and non-detection by common drug tests, consumption of synthetic cannabinoids as a 'legal' alternative to cannabis is currently a serious problem, particularly in psychiatric clinics. We present data from 900 forensic & clinical samples analyzed for synthetic cannabinoids between May 2010 and February 2011.

Materials and Methods: Analysis was performed using 1 mL of serum and alkaline liquid-liquid extraction. Chromatographic separation was achieved on a Shimadzu HPLC system with gradient elution using 2 mM ammonium formate/0.2 % formic acid as solvent A and methanol as solvent B. Determination of aminoalkylindoles was achieved by LC-ESI-MS/MS (Q-Trap 3200 or Q-TRAP 4000 mass spectrometer, AB Sciex) using scheduled multiple reaction monitoring (sMRM) in positive ionization mode. Limits of quantification and detection were set to 0.1 ng/mL, whereas the method proved to be linear between 0.1 and 2 ng/mL. The method is updated regularly and currently covers 20 synthetic cannabinoids of the aminoalkylindole type.

Results: 41 % of 900 serum samples analyzed between May 2010 and February 2011 were tested positive for synthetic cannabinoids (median age: 28 y; 94 % males; 6 % females). The most abundant analytes detected were JWH-081 (66.8 %), JWH-122 (40.8 %), JWH-250 (34.0 %), JWH-210 (24.7 %) and JWH-018 (19.3 %). So far, 11 of the total 20 synthetic cannabinoids covered by the method have been detected in serum. Several forensic psychiatric or drug rehabilitation clinics sent samples monthly as a follow-up for up to 10 months. At the beginning, synthetic cannabinoids were confirmed in up to 82 % of all case specimens, whereas this number decreased to 12 %. We analyzed consecutive serum samples of 3 patients, who stopped using synthetic cannabinoids after they had used 'herbal incense' products over several weeks excessively. Patient 1 and 2 were tested positive for JWH-081, which was detectable in serum for at least 32 and 58 days, respectively. Patient 3 was tested positive for JWH-210 and still showed positive serum results on day 6 after cessation of drug use. In all cases abstinence was ensured by the nursing staff of the psychiatric clinics.

Conclusions: The high prevalence of positive samples and the extensive spectrum of detected compounds provide evidence for the need for highly specific and sensitive methods which need to be updated regularly to confirm the consumption of 'legal highs,' containing synthetic cannabinoids. Application of the presented LC-ESI-MS/MS screening method was highly preventative, since the number of positive samples decreased dramatically within a few months, ensuring successful therapy in forensic psychiatry and drug rehabilitation clinics. Finally, extended detection of JWH-081 and JWH-210 after heavy consumption in 3 cases confirmed that synthetic cannabinoids, like Δ^9 -tetrahydrocannabinol, are distributed to fatty tissues and likely have a long terminal elimination half life.

Key Words: Synthetic Cannabinoids, Serum, LC-ESI-MS/MS

Synthetic Cannabinoid Use: Experience with Urine Drug Testing

Sherri L. Kacinko* and Barry K. Logan.

NMS Labs, Willow Grove, PA

Objectives: Synthetic cannabinoids are an analytical challenge to the toxicology community. In order to assist medical examiners, police departments and hospitals detect use of JWH-018 and JWH-073, an assay for the identification of metabolites of these analytes was developed. Between September 30, 2010 and March 31, 2011 over 2000 urine specimens were analyzed. Review of data from this period offered the first information on demographics and frequency of positive samples in a population of suspected users. In addition, an in-depth review of the data gave an opportunity to evaluate the effectiveness of a novel approach used as a model for compounds for which no certified reference material exists.

Methods: At the time of method development (Fall 2010), no reference standards were available for putative metabolites of JWH-018 or JWH-073. Shortly after the method was validated, Cayman Chemical (Ann Arbor, MI) began selling a series of metabolites of both compounds. For each parent compound, the metabolite series consists of hydroxylation on the four available positions on the indole ring, the side-chain terminal carbon, and the corresponding carboxylic acid. We obtained samples of these standard reference materials and evaluated their utility using authentic positive urine specimens. It was determined that these metabolites were not the major mono-hydroxy metabolite in urine from persons who consumed JWH-018 or JWH-073. Pending identification and synthesis of the major metabolite, a conservative approach of identifying the metabolite simply as "JWH-018 metabolites" or "JWH-073 metabolites" has been adopted. The criteria for reporting a positive sample are: 1) all monitored transitions (two per analyte, or internal standard) must be present with a signal to noise ratio of at least 10:1; 2) the relative retention time of each transition must be within $\pm 2\%$ of the positive control; 3) the transition ratio of the unknown sample must be $\pm 30\%$ of the positive control; 4) both the mono- and di-hydroxy moieties must be present.

Results: As of March 31, 2011, 2060 urine specimens have been analyzed according to this standard. Positive samples were confirmed on a separate aliquot. The repeat analyses were congruent in 100% of cases. Most cases were negative (70.4%) with 20.3% positive for only JWH-018 metabolites and 8.9% positive for metabolites of both compounds. One case was positive for only JWH-073 metabolites. There were 609 cases positive for at least one compound. Gender and age were available for 474 and 475 of these cases, respectively; 91% were male. Eight samples were collected from individuals under 10 years of age. One (age 3 years) was positive for JWH-018 and JWH-073 metabolites. In the remaining positive cases, nearly 27% were from individuals ≤ 20 years old (Range = 14-62 years, Mean = 24.0 years, Median = 22 years). Review of a selection of cases indicated that in 10% of cases, monohydroxy JWH-018 was present in the absence of the dihydroxy metabolite while 6% of cases contained monohydroxy JWH-073 but not dihydroxy JWH-073. These cases were reported as undetected according to our criteria.

Conclusions: The lack of certified reference standards offers a unique challenge in the implementation of an analytical method to identify the metabolites of novel drugs. In a forensic context, it is important to take a conservative approach to maximize confidence in the reported results. The approach that was developed can be applied to new substances as they replace JWH-018 and JWH-073 which have been recently controlled.

Key Words: Synthetic Cannabinoids, Urine, Validation

Development and Validation of an LC-MS/MS Method for the Detection and Quantification of Designer Drugs, Amphetamines, Benzodiazepines, Opiates and Opioids in Urine Using Turbulent Flow Chromatography

Nadine Schäfer*, Benjamin Peters and Andreas Ewald

Institute of Legal Medicine, Saarland University, Building 42, D-66421 Homburg (Saar), Germany

Objectives: In the context of driving ability diagnostics in Germany, administrative cut offs for various drugs and pharmaceuticals were established in urine (Schubert, Mattern, Kirschbaum Verlag Bonn, 2009). We developed and validated an LC-MS/MS method for the simultaneous detection and quantification of designer drugs, amphetamines, benzodiazepines, opiates and opioids in urine.

Materials and Methods: Urine samples were diluted with acetate buffer (pH 4) 1:1 and fortified with an internal standard solution containing amphetamine-D5, metamphetamine-D8, 3,4-methylenedioxyamphetamine (MDA)-D5, 3, 4-methylenedioxymethamphetamine (MDMA)-D5, N-ethyl-3,4-methylenedioxyethylamphetamine (MDEA)-D5, morphine D3, codeine-D3, dihydrocodeine-D6, 2-ethylidene-1,5-dimethyl-3,3-diphenylpyrrolidine (EDDP)-D3, benzoylecgonine-D3, diazepam-D5, oxazepam-D5 and alprazolam-D5. After enzymatic cleavage using β -glucuronidase/arylsulfatase, online extraction was performed by an ion exchange/reversed phase turbulent flow column. Separation was achieved using a Thermo Fisher (TF) Hypersil Gold aQ reversed phase column and gradient elution. For detection, a TF TSQ Quantum Ultra triple stage mass spectrometer with an electrospray ionization (ESI) interface was used and the analytes were measured with multireaction monitoring for two transitions of each precursor ion. Validation was carried out according to the guidelines of the Society of Toxicological and Forensic Chemistry (GTFCh, Toxichem Krimtech 2009;76(3)).

Results: Table 1 displays results of the validation experiments. Analysis runtime was 25 min.

Analyte	Limit of detection [ng/mL]	Linearity range [ng/mL]	Cut off [ng/ml]	Transitions	
Amphetamine	5.6	25-225	50	136/91	136/119
Metamphetamine	2.0	25-225	50	150/91	150/119
MDA	1.4	25-225	50	180/133	180/163
MDMA	2.0	25-225	50	194/105	194/163
MDEA	1.5	25-225	50	208/133	208/163
Benzoylecgonine	4.9	25-225	30	290/105	290/168
EDDP	1.6	25-225	50	278/234	278/249
Morphine	1.6	12.5-100	25	286/165	286/201
Codeine	2.5	12.5-112.5	25	300/165	300/215
Dihydrocodeine	1.1	12.5-112.5	25	302/199	302/201
Diazepam	2.1	25-250	50	285/154	285/193
Nordiazepam	1.5	25-250	50	271/140	271/165
Oxazepam	2.0	25-250	50	287/241	287/269
Lorazepam	2.5	25-250	50	321/275	321/303
Bromazepam	3.2	25-250	50	316/182	316/209
OH-Alprazolam	1.5	25-250	50	325/243	325/279
7-Aminoflunitrazepam	4.4	25-250	50	284/135	284/227

Conclusions: This method is suitable for quantification of multiple analytes at the cut off concentrations required for driving ability diagnostics in Germany. Turbulent flow chromatography provided fast and simple sample preparation and increased sample throughput.

Key Words: Turbulent Flow Chromatography, LC-MS/MS, Driving Ability Diagnostics

Prediction of Liquid Chromatographic Retention for Differentiating Structural Isomers

Elli Tyrkkö*, Anna Pelander and Ilkka Ojanperä.

Hjelt Institute, Department of Forensic Medicine, FI-00014 University of Helsinki, Finland

Objectives: Lack of reference standards pushes forensic toxicologists to find alternative methods for compound identification. Accurate mass measurement by high resolution mass spectrometry allows the determination of elemental composition, but this technique is unable to differentiate structural isomers. A variety of in silico tools are available to facilitate various stages of the analytical process and compound identification. Our in-house toxicology database includes molecular formula (m/z ranging from 122.0964 to 656.2271) and retention time data obtained by reference standards for 486 drug compounds. The capability of commercial software for predicting chromatographic retention was evaluated as an additional tool in compound identification. The aim of the study was to predict the retention order of the 118 isomers (m/z 155.1277 – 387.1559) found in this database, comprising 50 isomer groups.

Materials and Methods: A retention time knowledge base for the 486 compounds included in the in-house toxicology database was created by ACD/ChromGenius software (ACD/Labs, Toronto, Canada). This software uses the self-created knowledge base of molecular structures and experimental retention data to predict the retention times of new compounds by using built-in physicochemical prediction algorithms. The chromatographic separation was performed in non-linear gradient mode at 40°C with Luna PFP(2) column (Phenomenex, Torrance, CA, USA) using 2 mM ammonium acetate in 0.1% formic acid and methanol as mobile phase components. The flow rate was 0.3 mL/min, and analysis time was 20 min. The predicted retention times were compared to the experimental values, and the retention order of structural isomers was generated.

Results: Among the 50 isomer groups with 2-5 compounds each, the retention order of the compounds was correctly predicted in 68% (34 groups). Two diastereomer pairs were included in the 16 isomer groups for which the software failed to determine the correct retention order. Correlation between the calculated and experimental retention times in the ACD/ChromGenius knowledge base was adequate ($r^2 = 0.853$). Absolute average and median retention time errors in the knowledge base were 1.12 and 0.84 min, respectively.

Conclusion: The results show that despite the rather large absolute errors between the predicted and experimental retention times, the software proved to be useful in determination of the correct retention order of most compounds. By combining the data produced with ACD/ChromGenius with those from other in silico tools employing accurate mass, a tentative compound identification in a large target database is possible even for those substances for which a reference standard is unavailable.

Key Words: Retention Time, Prediction, Structural Isomers

Combined Urine Drug Screening and Confirmation by Liquid Chromatography-Time-of-Flight Mass Spectrometry and Database Search Including Exact Mass Qualifier Ion(s)

Ana de Castro^{*1,2}, Anna Pelander³, Merja Gergov³ and Ilkka Ojanpera³

¹Toxicology Service. Institute of Forensic Sciences. University of Santiago de Compostela, Spain; ²Research Department. Cienytech, S.L. Santiago de Compostela, Spain; ³Department of Forensic Medicine. University of Helsinki, Finland

Objectives: To develop a LC/TOF-MS database including exact mass qualifier ion data for 431 parent drugs and metabolites and to compare urine drug screening results with this method to those obtained with the database containing precursor ion exact masses only. In addition, to compare limits of detection (LODs) achieved with the LC/TOF-MS database including exact mass qualifier ions to those obtained with laboratory's current LC/IT-MS confirmation method.

Materials and Methods: The chromatographic system was an Agilent 1100 series system (Waldbronn, Germany) and the mass spectrometer was a Bruker MicrOTOF (Bruker Daltonics, Bremen, Germany). Analyte fragmentation was performed by in-source collision induced dissociation (ISCID) at 200 and 85 V for capillary exit and skimmer 1 voltages, respectively. Accurate mass fragments to be used as qualifier ions for each analyte were selected by direct observation of the spectrum and the aid of two predictive software, SmartFormula3D (Bruker Daltonics) and ACD/MS Fragmenter (Advanced Chemistry Development, Toronto, Canada). To assess the usefulness of qualifier ions, twenty-five authentic urine specimens were analyzed with laboratory's current LC/TOF-MS method with no analyte fragmentation, and then with the LC/TOF-MS method using MSMS fragmentation mode. When no fragments are monitored, results are generated based on selected limits for retention time window (when available), precursor area count, mass error and mSigma (isotopic pattern); additional parameters required for a positive finding when applying the new database were area count and mass error for the most prominent qualifier ion. Finally, sensitivity provided by the current LC/IT-MS confirmation method and by the ISCID LC/TOF-MS method was compared by determination of LODs in urine samples for 49 representative analytes included in the LC/TOF-MS database.

Results: With the applied ISCID fragmentation conditions, 14.8% of the 431 analytes showed one distinctive qualifier ion, 81.4% showed at least 2 qualifiers, 64.5% showed 3 qualifiers, and no qualifiers were available for 3.7% of the analytes. Comparing results obtained with or without qualifier monitoring, false positive results due to co-eluting isomeric interferences could be avoided in 6 out of 8 cases when including qualifiers. However, higher LODs for some analytes were achieved, producing false negative results in 11 urine specimens. In 9 of 11 false negative cases, precursor area of the unidentified analyte was very close to the minimum value for compound identification. ISCID LC/TOF-MS and LC/IT-MS LODs were in the ng/mL levels for all analytes. For the majority of the analytes tested, similar or slightly higher LODs were achieved with the TOF mass spectrometer, and only for 6 analytes LODs were 4 to 7 times higher.

Conclusions: A LC/TOF-MS database is presented for toxicological analysis including exact mass qualifier ion(s) for approximately 400 analytes. Although qualifier ions monitoring slightly increases LODs values, it provides analyte structural information and, therefore, increases results confidence. Furthermore, identification of at least one analyte fragment ion during confirmatory testing via ISCID LC/TOF-MS fulfils the European Commission Decision 2002/657/EC criteria.

Key Words: LC/TOF-MS, Exact Mass Qualifier Ion, Urine Drug Screening

In Vitro Stability of Cannabinoids and Cannabinoid Glucuronides in Authentic Whole Blood and Plasma Specimens Following Controlled Smoked Cannabis

David M. Schwope*, Erin L. Karschner, Karl B. Scheidweiler, David A. Gorelick and Marilyn A. Huestis
Chemistry and Drug Metabolism, IRP, National Institute on Drug Abuse, NIH, Baltimore, MD

Supported by the Intramural Research Program, National Institute on Drug Abuse, NIH

Introduction: Analyte stability is an important consideration for cannabinoid test interpretation. Existing whole blood and plasma cannabinoid stability data primarily evaluated fortified samples, rather than authentic specimens collected after controlled cannabis administration. To our knowledge, no THC-glucuronide stability data exist. We determined free and glucuronide cannabinoid stability in whole blood and plasma specimens for up to 28 days after controlled cannabis smoking, with specimens analyzed within 24 h of collection.

Methods: Cannabis smokers provided written informed consent to participate in this NIDA IRB-approved study. Whole blood and plasma specimens collected at 6 time points after ad libitum smoking of a 6.8% Δ^9 -tetrahydrocannabinol (THC) cigarette were quantified by a validated LCMSMS method. Low- and high-THC concentration pools were prepared for each participant by combining pharmacokinetic specimens. Pools were mixed, aliquoted in polypropylene cryotubes and stored within 2 h of collection at -20°C , 4°C or room temperature (RT) in the dark. Baseline specimens were analyzed in triplicate within 24 h of collection, with remaining aliquots analyzed in duplicate after 7, 14 and 28 days at -20°C and 4°C , and after 7 days at RT. Limits of quantification (LOQ) in plasma and whole blood were THC, 11-hydroxy-THC (11-OH-THC), 11-nor-9-carboxy-THC (THCCOOH), cannabidiol (CBD) and cannabinol (CBN) 1.0 ng/mL, THC-glucuronide 0.5 ng/mL and THCCOOH-glucuronide 5.0 ng/mL. Specimens with concentrations \geq LOQ were included in calculations; concentration changes within $\pm 20\%$ were considered stable.

Results: 10 cannabis smokers (9 M, 1 F) participated. Number of cannabinoid analyte concentrations \geq LOQ (whole blood low and high pools; plasma low and high pools) were: THC (10, 10; 10, 10), 11-OH-THC (10, 10; 10, 10), THCCOOH (10, 10; 10, 10), CBD (0, 2; 0, 6), CBN (0, 6; 0, 8), THC-glucuronide (0, 3; 0, 7) and THCCOOH-glucuronide (10, 10; 9, 9). In low and high whole blood pools, mean THC, 11-OH-THC, CBD, CBN, and THC-glucuronide concentrations were stable ($< 20\%$ change) after 4 weeks at -20°C and 4°C , and 1 week at RT (longest period evaluated). In the high-THC pool, mean THCCOOH concentrations also were stable at -20°C and 4°C for 4 weeks. THCCOOH-glucuronide was stable at -20°C for 4 weeks, unstable at 4°C for 4 weeks (mean decreases of -24.1%), and markedly unstable at RT with mean concentration changes of -40.2% and -45.3% at 1 week for low and high pools, respectively. Under these conditions, mean THCCOOH concentrations increased by 21.7% and 11.8% , respectively. Plasma cannabinoid concentrations were stable at -20°C for all analytes, including the glucuronides; however, after 4 weeks at 4°C mean THCCOOH-glucuronide concentrations decreased by 66.7% and 74.5% , while THCCOOH concentrations increased by 25.7% and 15.6% in the low and high pools, respectively. Free and conjugated THCCOOH concentrations were unstable after 1 week at RT in both pools, although other analytes were stable under these conditions.

Discussion: Extensive protein binding in authentic whole blood and plasma specimens may improve stability of cannabinoids in these fluids; one factor may be limited adsorption to container surfaces. Frozen specimen storage (-20°C) provided maximum stability, although short-term (28 day) refrigerated storage (4°C) may be acceptable for whole blood determinations where analysis of THCCOOH-glucuronide is not required. Refrigerated plasma storage is not recommended for longer than 2 weeks when free THCCOOH concentrations are required due to deconjugation of THCCOOH-glucuronide. However, THC concentrations were stable in both matrices under all conditions tested, limiting impact on impairment determinations.

Key Words: Cannabinoids, Stability, THC, Whole Blood, Plasma

Fast Targeted Screening of 234 Drugs and Poisons in Urine Using LC/MS/MS

Jochen Beyer^{1,2,*}, Catherine J. Wort¹, Matthew Di Rago¹, Dimitri Gerostamoulos^{1,2}, and Olaf H. Drummer^{1,2}

¹Victorian Institute of Forensic Medicine, Melbourne, Australia; ²Department of Forensic Medicine, Monash University, Melbourne, Australia

Aims: Targeted screening methods that cover a broad range of common drugs and drugs of abuse are essential for forensic laboratories. The most common techniques include immunoassays, GC-MS, and more recently LC-MS(MS). The major advantages of immunoassay techniques are their easy use and fast turnaround times, however, mass spectrometric techniques are more selective and/or sensitive but technically more demanding. The aim of this study was to develop a LC-MS/MS based screening technique that covers the most common drugs observed in forensic analysis, using a fast extraction method combined with fully automated data processing.

Methods: After overnight enzymatic hydrolysis, liquid-liquid extraction (LLE) of 2 mL of urine, 234 of the most common drugs and drugs of abuse including their most common metabolites were separated using an Agilent 1200 HPLC system with an C18 separation column (Eclipse XBD C18, 4.6 × 150 mm, 5µm), using gradient elution with a mobile phase of 50 mM ammonium formate buffer pH 3.5 / acetonitrile. The drugs were detected using an Applied Biosystems 3200 Q-TRAP LC-MS-MS system (ESI, MRM mode). For the 14 most common drugs of abuse, the method was fully validated according to international guidelines for quantitative analysis. All other compounds were identified and semi quantitatively determined using a one-point calibration. Data processing was performed using a custom designed macro based on Analyst Reporter 2.0 software.

Results: The targeted screening method covers the following drug classes: antidepressants (34 analytes), antipsychotics (36 analytes), benzodiazepines (28 analytes), stimulants (22 analytes), opioids (26 analytes), antihistamines (16 analytes), and miscellaneous drugs (72 analytes). The detection limit of the assay met the recommended detection limit for common DFSA drugs (published by the Society of Forensic Toxicologists). The assay was found to be selective for the compounds of interest. With a few exceptions, recoveries were typically >70%. Accuracy, repeatability and intermediate precision were within the required limits for the 14 most common drugs of abuse. All other drugs obtained satisfactory accuracy and precision data using a one-point calibration. Data processing was automated based on custom built settings. All quantifier transition peaks matching the retention times within 2% maximum difference that resulted in a calculated concentration above the lowest calibrator were reported as positive.

Conclusions: The presented LC-MS-MS assay has proven to be applicable for determination of the studied analytes in urine. The fast and reliable extraction method combined with automated processing gives the opportunity for fast turnaround times.

Key Words: LC-MS-MS; Screening; Urine

Evaluation of Phosphatidylethanol Concentrations in Drinking Experiments**Heike Gnann**^{*1}, Annette Thierauf¹ and Wolfgang Weinmann²¹Institute of Legal Medicine, University Medical Centre, Albertstrasse 9, 79104 Freiburg, Germany; ²Institute of Forensic Medicine, Medical Faculty, University of Bern, Buehlstraße 20, CH-3012 Bern, Switzerland

Objectives: Phosphatidylethanol (PEth) is a direct marker of alcohol consumption. It is formed in the membranes of red blood cells via a transphosphatidylation reaction. This marker generally indicates high volumes of alcohol consumption by an individual over a long period of time. Although PEth was previously detected after one single large ethanol dose, little is known about PEth in social drinkers. The aim of this study was to describe formation kinetics of PEth by simulating extensive drinking. After three weeks of alcohol abstinence eleven subjects (5 female, 6 male, 19-75 years of age, average BMI: 23.5 kg/m²) drank ethanol on five successive days in an amount leading to an estimated blood ethanol concentration (BAC) of 0.1% each day (average amount of Vodka: 245 mL, drinking within one hour). Afterwards they were abstinent for 16 days with regular blood sampling. PEth results were compared to alcoholics at the beginning of alcohol withdrawal therapy.

Materials and Methods: During dosing, blood alcohol levels were calculated using the Widmark formula including a resorption deficit of 30% and a degradation rate of 0.02 mg/mL/h. Blood alcohol values in collected samples were obtained using a DRI[®] Ethyl Alcohol Assay and a standardized headspace GC-FID. For PEth analysis, a liquid-liquid extraction was performed using isopropanol and n-hexane. Afterwards the samples were evaporated, redissolved in mobile phases A/B (25/75; v/v), and injected into an LC-MS/MS (HPLC 1100 system (Agilent) and QTrap 2000 triple quadrupole linear ion trap mass spectrometer (AB Sciex)). Compounds were separated on a Luna Phenyl Hexyl column (50 mm×2 mm, 3 µm) by gradient elution, using A: 2 mM ammonium acetate and B: methanol/acetone (95/5; v/v). The MS/MS was operated in negative mode using multiple reaction monitoring (MRM). MRM transitions for PEth with the fatty acid moieties 16:0/18:1 were m/z 701.5-281.2 and m/z 701.5-255.2, for phosphatidylpropanol as internal standard m/z 741.5-281.2. Calibration was linear in the range from 30 to 1000 ng/mL, with a limit of quantitation of 30 ng/mL for PEth 16:0/18:1.

Results: All participating drinkers except one (BAC 0.099%) reached alcohol concentrations above 0.1% (individual maximum values for 10 subjects ranged from 0.103% to 0.183%). Subjects' highest PEth 16:0/18:1 concentrations ranged from 74 to 237 ng/mL measured on the fourth to the sixth day after the first drink. Comparing these values with those from alcoholics (total PEth values ranged from approximately 1700 ng/mL (Varga et al., 2000) to 6000 ng/mL (Helander et al., 2009)), it was clear that extensive drinking over only five days did not result in PEth concentrations comparable to those from alcoholics.

Conclusions: This study demonstrates that short drinking periods with high ethanol did not produce PEth values in the range of 1700 to 6000 ng/mL reached by alcoholics. To set a limit for differentiation between heavy and social drinking, more studies should be conducted on PEth after multiple moderate alcohol doses.

Key Words: Alcohol Marker, Phosphatidylethanol, LC-MS/MS

Unusual Codeine-to-Morphine Ratio in a Hair Sample: Indicator for CYP2D6 Polymorphism?

Markus R. Baumgartner*, Kristina Y. Rust, Thomas Kraemer
Institute of Legal Medicine, University of Zurich, Zurich, Switzerland

Objectives: In two routine samples from the same person within the context of regaining the driving license, an unusual codeine-to-morphine ratio of 3.7 in hair samples was observed. 257 codeine-only cases were reanalyzed for assessing the codeine-to-morphine ratio. Genotyping of the person was also done.

Methods: Hair snippets were extracted in two steps. Analytes were separated on a Shimadzu Prominence HT HPLC-System with a Phenomenex column (Synergi 4 μ m Polar RP 80A, 150/2.0), gradient elution with a mobile phase of 1 mM formic acid /CH₃CN with ammonium formate buffer pH3 and a total flow of 0.5 mL/min. Analytes were detected on an AB Sciex 3200 Q-Trap LC-MS-MS system (ESI, MRM-IDA-EPI). Limits of quantification for codeine and morphine were 50 and 20 pg/mg, respectively. The codeine and morphine concentrations in 257 codeine cases were determined and the codeine-to-morphine ratios evaluated. Genotyping (CYP2D6 variants *3,*4,*5,*6, and *2x2) was performed in the university hospital laboratory.

Results: The codeine concentrations in the analyzed hair samples ranged from 50 to 19500 pg/mg of hair (median 140 pg/mg). Interestingly, in most of the cases only codeine but no morphine could be detected. In only 12 cases, corresponding morphine concentrations were found. Codeine-to-morphine ratios were greater than 50 except for one case with a ratio of 22. Only in the unusual samples was a low ratio of only 3.7 observed, This might be an indication for a CYP2D6 ultra-rapid metabolizer (UM). Genotype of this person was CYP2D6*1/*4, indicative of an immediate metabolizer. In 6 cases with high codeine concentrations (>1000 pg/mg), no morphine was observed, suggesting that they were poor metabolizers (PM) for CYP2D6.

Conclusion: Morphine is found in hair samples after intake of codeine in only in a few cases. Usually, a codeine-to-morphine ratio >50 is observed. Significantly lower ratios might be an indication for a UM status of the person tested. In this case, the first genotyping results are indicative of an intermediate metabolizer. However, other allele variants must be tested. In an ongoing study in our lab, CYP2D6 metabolizer status of volunteers are being determined and concentrations of codeine and morphine in hair tested.

Key Words: Hair Analysis, Codeine-to-Morphine Ratio, CYP2D6

Investigating Prehistoric Hallucinogen Consumption: An Archaeological Case Study from Lipez, Bolivia

Melanie Jayne Miller*¹, Christine Moore², Jose Capriles³, Juan Albarracin-Jordan⁴

¹UC Berkeley, Berkeley, CA, USA; ²Immunalysis, Pomona, CA, USA; ³Washington University, St. Louis, MO, USA; ⁴Fundación Bartolomé de las Casas, La Paz, Bolivia

Introduction and Objectives: Humans often seek to alter their state of consciousness through consumption of mind-altering substances, and we observe this in contemporary cultures around the world. Archaeologists are uniquely positioned to investigate the social contexts of ancient uses of psychoactive elements. Previous archaeological excavations in the South American Andes have recovered artifacts and ecofacts that provide evidence for prehistoric use of mind-altering substances by peoples in this region. Recovered lines of evidence include archaeological artifacts such as elaborately decorated snuff tablets, iconographic representations, and paleobotanical evidence of plants containing psychoactive substances that are believed to have been used in the past in association with specialized ritual activities. Recent excavation of a cave in the Lipez region, in South-western Bolivia, yielded fascinating archaeological artifacts including a well-preserved 'shaman's kit' and a number of braids of human hair. These two items are believed to have once been accompanied by a mummy that was removed sometime in the past. A piece of leather from the 'shaman's' bag was radiocarbon dated to 1000 BCE. Snuff tablets, a snuff tube, and a small preserved plant on a textile string were found in the leather bag. Therefore, we hypothesize that the individual using these items in the past consumed psychoactive substances.

Methods: Small samples (approximately 10mg) of two of the human hair braids and some plant materials were analyzed by GC-MS and/or LC-MS/MS for substances including harmaline, harmalol, dimethyltryptamine, harmine, yohimbine, mescaline, and bufotenine as well as cocaine and metabolites (LOQ 50pg/mg for cocaine). The plant materials included taxa, observed in archaeological contexts in south-western South America, known to contain psychoactive compounds: *Banisteriopsis caapi* (Ayahuasca), *Psychotria viridis* (Chacruna), *Anadenanthera colubrina* (Wilca), *Erythroxylum coca* (Coca), and *Echinopsis pachanoi* (San Pedro cactus).

Results: Though initial analysis of human hair samples provided inconclusive results, it is possible that the samples did not capture time periods when the individual was using psychoactive substances (since the samples were 1-2cm cross-sections representing one to two months of hair growth). It is possible the person consumed psychoactive substances but they degraded and were not recovered in the methods used. There is also the possibility that the recovered hair was not from a person who consumed any mind-altering chemicals, or the hair was not actually associated with the 'shaman's kit.' Further analysis of an entire braid of human hair from this archaeological context may be possible in the future.

Conclusions: Investigation of direct consumption of psychoactive and hallucinogenic substances by humans in the past has only recently been possible and provides a unique opportunity to investigate the role of these substances in ancient social systems.

Key Words: Hallucinogens, Human Hair, Archaeology

Segmental Hair Analysis as a Useful Tool in Assessment of Prenatal Exposure to Diazepam.

Monika Seńczuk-Przybyłowska^{*1}, Ewa Florek¹, Wojciech Piekoszewski², Wojciech Lechowicz³, Maksymilian Kulza¹, Grzegorz Henryk Bręborowicz⁴

¹Laboratory of Environmental Research, Department of Toxicology, University of Medical Sciences in Poznan, Poland; ²Department of Analytical Chemistry, Jagiellonian University, Cracow, Poland; ³Institute of Forensic Research, Cracow, Poland; ⁴Department of Perinatology and Gynecology, University of Medical Sciences in Poznan, Poland

Introduction: Benzodiazepines are drugs frequently prescribed to pregnant women for anxiety disorders, preeclampsia management, sedation and muscle relaxation. Although their hazardous effects on the developing fetus was confirmed, it is still important to assess the risk and advantages to maternal and child health.

Objectives: To determine if segmental analysis of maternal hair provides retrospective information about medication intake.

Materials and Methods: Pregnant women who took benzodiazepines during pregnancy were enrolled in the experimental group. The women completed questionnaires describing their medical history, type, dose and frequency of benzodiazepine intake. Hair samples were collected from women with singleton pregnancies and their respective newborns. Hair samples were decontaminated by subsequent washing with phosphate buffer, isopropanol and methylene chloride. To approximately 10 mg of powdered hair, 20 μ L of diazepam-d5 - 400 pg/mg was added. After hydrolytic digestion with phosphate buffer, an extraction with 1.2 mL diisopropyl ether was performed. Separation of analytes was performed with a gradient mobile phase on Zorbax Eclipse XDB-C18 Rapid Resolution HT column. Detection was carried out by LC-ESI-MS/MS 6460 Triple Quad Mass Spectrometer.

Results: Hair specimens were collected from 50 mother-infant dyads. Time and doses of diazepam administered to patients during pregnancy differed from 1 to 9 months and from 2 to 15 mg respectively (mean dose was 7.6 ± 3.6 mg/day). Mean \pm SD diazepam concentrations in maternal hair for the first, second and third trimesters based on segmental analysis were 30.8 ± 15.3 and 31.6 ± 36.0 and 34.1 ± 42.4 pg/mg, respectively. In the hair of newborns, mean concentrations were 53.3 ± 36.5 pg/mg. Nordiazepam concentrations in maternal hair were significantly higher: 64.5 ± 61.5 , 52.9 ± 48.1 and 89.9 ± 122.8 pg/mg for the three semesters, respectively. Concentration of the metabolite in newborns' hair (108.1 ± 144.2 pg/mg) was about twice as high as diazepam.

Conclusions: These data demonstrate that both substances are incorporated in hair matrix, which enables the use of segmental hair analysis as a tool of exposure evaluation. Moreover, both substances were detected in newborns' hair that indicates that their presence may be a marker of fetal exposure. More precise information about the time of exposure may be possible by dividing hair shafts into segments, corresponding to the three trimesters of pregnancy.

Key Words: Prenatal Exposure, Benzodiazepines, Hair Analysis

Simultaneous Quantification of Drugs of Abuse in Oral Fluid Collected with the Statsure, Quantisal or Certus Device By UPLC-MS/MS

Vincent Di Fazio*, Sarah MR Wille and Nele Samyn

Laboratory of Toxicology, National Institute of Criminalistics and Criminology, Chaussée de Vilvorde 100, Brussels, Belgium

Introduction: In Belgium, practical demands from police officers and judicial authorities led to the modernization of the legislation for driving under the influence of drugs (DUID). This law, based on analytical cut-offs (25 ng/mL for amphetamines, 5 ng/mL for morphine/6-acetyl morphine (6AM) and 10 ng/mL for cocaine/benzoylecgonine), requires an oral fluid on-site test (Drugwipe 5⁺), which is confirmed by oral fluid analysis using chromatographic techniques.

Objective: An ultra-performance liquid chromatography tandem mass spectrometry (UPLC-MS/MS) method was developed to quantify amphetamine, MDMA, cocaine, benzoylecgonine, 6AM and morphine in oral fluid. In addition, the method detected some other compounds-of-interest such as mephedrone, meta-chlorophenylpiperazine (mCPP) and methylphenidate. A complete validation was achieved according to international guidelines. Three commercially available oral fluid collectors [StatSure (Diagnostic Systems), Quantisal (Immunalysis) and Certus (Concateno)] were evaluated.

Method: A Xevo-Triple Quadrupole mass spectrometer (Waters, Milford, MA, USA) was coupled to the UPLC[®] system. A chromatographic separation was obtained using an Acquity UPLC[®] BEH C18 2.1 x 100mm x 1.7 μ m column at 55°C in a gradient mode composed of methanol and water containing 0.1% formic acid. A flow rate of 0.45 mL/min allowed us to separate our compounds within 8.50 min. MS tune parameters were established in ESI positive mode. Cone voltage and collision energy were optimized to generate two specific MRM transitions for each analyte and one for deuterated analogues. To improve specificity, product ion confirmation (PIC) scans were acquired simultaneously with MRM chromatograms. The pre-analytical step consisted of a SPE of 0.2 to 0.4 mL collected oral fluid (depending on the collection device) using MCX 3cc 60mg cartridges (Waters). To evaluate the performance of each collection device, the described method was fully validated using the three collectors comparing parameters as matrix effects, recovery, stability, precision, trueness, LOQ, etc.

Results: Matrix effects of different collectors were investigated at low and high concentrations by mixing blank saliva collected from different donors (n=5) with the appropriate collection buffer. No matrix effects were observed between the three different collectors at low (4 to 20 ng/mL) and high (100 to 500 ng/mL) concentrations; even if some ion suppression was observed for morphine (ranging from 44.3% to 61.1%) and 6AM (ranging from 28.1% to 37.8%), this phenomenon seems to be related to the oral fluid matrix itself and not to the collector buffer. However, these matrix effects were compensated for by the use of deuterated standards (Matrix effects from 85% to 116%). Calibration curves ranged from 12.5-800 ng/mL for amphetamine, MDMA, mephedrone, mCPP and methylphenidate; 2.5-160 ng/mL for morphine and 6AM; 5-320 ng/mL for cocaine and benzoylecgonine. SPE recoveries were reproducible (60-102% for all compounds, RSD <23% for 6AM/morphine and RSD <10% for others), concentration and collector independent. Repeatability and intermediate precision at the quantification limit (LOQ), and low, medium and high concentrations fulfilled the criteria of an RSD below 20% at LOQ and below 15% at the other concentrations.

Conclusion: A UPLC-MS/MS method for quantification of various drugs of abuse in oral fluid collected with the Statsure, Quantisal or Certus collector was successfully developed and validated.

Key Words: Drugs of Abuse (DOA), Oral Fluid Collection, Matrix Effects

Concentration of Cocaine and Cocaine Metabolites in Oral Fluid After Drinking Coca Tea**Eva M Reichardt**^{*1}, Dene Baldwin² and M. David Osselton¹¹Centre for Forensic and Biological Sciences, Bournemouth University, Fern Barrow, Poole, United Kingdom; ²Concateno, 92 Milton Park, Abingdon, Oxfordshire, England.

Objective: Oral fluid (OF) has gained wide popularity as a sample for drug testing as it is easy and non-invasive to collect. A number of papers have reported that cocaine concentrations rapidly appear in OF following smoking or intra-muscular injection from both residual contamination in the mouth and transfer from the blood into the OF via the saliva glands. We have not encountered any papers that investigate the effects of coca tea drinking on OF cocaine concentrations. This study was designed to investigate the effects of consumption of coca tea on oral fluid concentrations of cocaine and its metabolites after drinking a typical brew of coca tea. In Peru, cocaine is used legally and consumed either socially, in the form of a leaf infusion (tea), or via chewing. Customarily, coca chewing is more common in persons living or working at high altitude whereas, at coastal level cocaine tends to be consumed socially as tea. This study was undertaken in Lima, which has a coastal population where coca tea is consumed socially in preference to coca chewing.

Methods: Twenty-five volunteer residents in Lima, Peru, (age range 23 – 88 years of age) consumed coca tea and subsequently provided oral fluid specimens for analysis. Coca tea was prepared by soaking 10 whole coca leaves in boiling water for 5 minutes prior to straining to remove the leaf tissues. Before consumption, volunteers were asked to provide a blank oral fluid sample in order to establish a baseline. Volunteers drank 1 cup (~250 mL) of coca tea and provided a sample of oral fluid within 5 minutes after finishing the tea. OF was subsequently collected at 15, 30, 45 and 60 minute intervals. OF collection was facilitated using the Concateno “Certus” device with pH 4.5 buffer to reduce hydrolysis of cocaine to benzoylecgonine. OF samples were subsequently analyzed and quantified using LC-MS. The analytical method had a LOD of 0.1ng/mL, LOQ of 0.8ng/mL, imprecision of < 15% at 2ng /mL and was linear between 0.8ng/mL and 20,000ng/mL. No significant matrix effects were observed.

Results: Cocaine concentrations immediately after consumption of coca tea ranged from 0.01 µg/mL to 8.96 µg/mL, and in all 25 cases was still detectable 60 min following the end of tea drinking. Cocaine metabolites, ecgonine methyl ester (EME) and benzoylecgonine (BZE), were also detected with a maximum concentration of 16.69 µg/mL (range 0.03 µg/mL – 16.69 µg/mL) and 0.4 µg/mL (range 0.01 µg/mL – 0.45 µg/mL) respectively. Cocaethylene (CE) and anhydroecgonine methyl ester (AEME) were also detected and quantified in some samples (CE n = 6; AEME n = 9). The presence of CE and AEME would normally suggest prior cocaine use with alcohol and the smoking of cocaine free base, respectively; however, these substances were not detected in the baseline specimens.

Conclusions: The consumption of coca tea can result in the formation of significant oral fluid concentrations of cocaine and its metabolites BZE and EME. As expected, high concentrations of cocaine derivatives were detected immediately after coca tea consumption however, significant concentrations were also detected 1 h post-consumption. Such findings should be borne in mind when interpreting workplace or forensic data. We are unable to explain the appearance of CE and AEME in random OF samples.

Keywords: Oral Fluid, Coca Tea, Cocaine, Benzoylecgonine

Operation Paris: The Shannon Matthews Case**Craig Chatterton***

The Forensic Science Service, Washington Hall, United Kingdom.

Introduction: At 18:48 hrs on Tuesday 19th February 2008 Karen Matthews contacted the police to report that her 9 year old daughter, Shannon Matthews had not returned home from school. Extensive searching and enquiries resulted in Shannon being located, alive and well, twenty-four days later at the home address of Michael Donovan. Empty packets of travel-sickness medication were recovered from Donovan's address together with an unlabelled medicine bottle.

Methods and Results: Gas Chromatography Mass Spectroscopy (GC-MS) analysis of Shannon's urine sample confirmed recent drug ingestion of meclozine (brand name Traveleze), a readily available antihistamine/anti-emetic drug. Head-hair samples were collected from Shannon Matthews in the months following her discovery in March at Donovan's flat; these samples were collected in March, April and May 2008. Initial analysis was carried out on 3cm sections of hair using GC-MS and Liquid Chromatography Mass Spectroscopy (LC-MS). Assuming an average rate of growth, initial analysis investigated an approximate 12 month history of drug ingestion. Amitriptyline, Nortriptyline, Dihydrocodeine, Temazepam and Tramadol were detected in each segment of hair; these drugs formed part of Donovan's prescribed medication. The distribution of the drugs in Shannon's hair sample(s) demonstrated multiple drug exposure on more than one occasion, pre-dating the time of her disappearance.

Drug Detected (pg/mg)	0-3cm	3-6cm	6-9cm	9-12cm	12-15cm	15-18cm
Amitriptyline	5	19	61	121	156	182
Nortriptyline	2	13	46	83	111	114
Temazepam	2	4	7	9	13	12
Tramadol	30	90	220	380	540	860
Dihydrocodeine	10	20	40	90	120	140

Hair sample collected in May 2008; 3 months after Shannon was discovered. Without hair analysis this case would not have been fully investigated and evidence of drug administration over an extended time period (pre-dating the child's disappearance) would have gone unnoticed. This case has, therefore, demonstrated the added value of hair testing and emphasized the importance of using hair samples in isolation but also to complement conventional analysis. This scientific evidence was presented at court in November 2008. In December 2008 Karen Matthews and Michael Donovan were found guilty of kidnapping, false imprisonment and perverting the course of justice; they were each sentenced to serve 8 years in prison. This presentation details the forensic toxicology investigation which identified the aforementioned drugs and explains the findings/interpretation, as presented in court. There is little, if any, reported data on children's hair containing these prescription drugs.

Key Words: Segmented Hair Analysis, Child, GC & LC-MS

Δ^9 -Tetrahydrocannabinol (THC), 11-nor-9-Carboxy-THC (THCCOOH), Cannabidiol (CBD) and Cannabinol (CBN) in Oral Fluid Following Controlled, Smoked Cannabis

Dayong Lee*, David M. Schwobe, Garry Milman, Allan J. Barnes, David A. Gorelick and Marilyn A. Huestis.
Chemistry and Drug Metabolism, IRP, National Institute on Drug Abuse, NIH, Baltimore, MD

Supported by the National Institutes of Health, Intramural Research Program, NIDA

Introduction: Analytical advances in the simultaneous quantification of cannabinoids in oral fluid (OF) suggest approaches for determining recent cannabis smoking. As cannabis is the most commonly abused illicit drug, understanding its pharmacokinetics in OF is important for informed interpretation of test results.

Methods: Healthy 18-45 year old cannabis smokers using at least twice per month provided written informed consent for this Institutional Review Board-approved study, and resided in the secure research unit the evening prior to smoking. OF specimens were collected with the Quantisal™ device, 30 min before and up to 22 h after ad libitum smoking of a 6.8% THC cigarette. THC, THCCOOH, CBD and CBN were quantified by 2D-GC/MS. Limits of quantification (LOQ) were 0.5 ng/mL THC and CBD, 1 ng/mL CBN and 7.5 pg/mL THCCOOH.

Results: 10 subjects provided 80 OF specimens -0.5 h before and 0.25, 0.5, 1, 2, 3, 4 and 6 h after initiation of smoking; six stayed for an additional night providing specimens at 22 h. All 0.25 h, six 0.5 h, five 1 h and one 2 h specimen had insufficient OF volume based on Quantisal indicator failures, leading to underestimated cannabinoid OF concentrations. Prior to dosing, 4 subjects were positive for THC (range 2.0-13.6 ng/mL) and 9 for THCCOOH (11.8-359 pg/mL). THC concentrations were highly elevated for 1-2 h with medians (range) of 644 (68.0-10284), 212 (40.0-6362), 287 (18.9-2440) and 94.1 (16.0-519) ng/mL at 0.25, 0.5, 1 and 2 h, respectively. All specimens were positive at 6 h. Four of 6 subjects were still positive at 22 h (0.5-5.5 ng/mL). OF THCCOOH decreased more slowly with medians (range) of 74.4 (9.6-647), 111 (12.1-665), 42.4 (8.9-232), 47.5 (14.8-263) and 15.9 (0.0-103) pg/mL at 0.25, 1, 3, 6 and 22 h, respectively. 96% of subjects' OF specimens were THCCOOH-positive for 6 h; two 0.5 h collections were negative, likely due to insufficient sample volume. Five of 6 subjects were THCCOOH-positive at 22 h. Maximum CBD and CBN occurred within 0.5 h. CBD was last positive in 3 subjects at 6 h (0.6-2.1 ng/mL). CBN also rapidly decreased, and was positive in 4 subjects at 6 h (1.0-4.4 ng/mL). THC and CBD ($r=0.994$; $p<0.001$) and CBN ($r=0.985$; $p<0.001$), but not THCCOOH ($r=0.088$; $p=0.588$), were strongly correlated immediately after smoking (0.25-2 h). At the Substance Abuse and Mental Health Services Administration (SAMHSA) proposed 2 ng/mL THC cutoff, all subjects were positive at 6 h and two at 22 h. We proposed a cutoff of $\text{THC} \geq 2$ ng/mL and $\text{THCCOOH} \geq 20$ pg/mL to reduce the possibility of potential environmental cannabis smoke contamination. At this cutoff, 9 subjects' window of detection was <22 h, while one remained positive. With an alternate cutoff of $\text{THC} \geq 2$ ng/mL and $\text{CBD} \geq 0.5$ ng/mL or $\text{CBN} \geq 1.0$ ng/mL, the last positive OF test was ≤ 6 h. With $\text{THCCOOH}/\text{THC} \leq 4$ pg/ng, OF cannabinoid tests were positive ≤ 6 h, except for one at 22 h.

Conclusions: THC and THCCOOH were detected in OF for at least 22 h, while CBD and CBN were positive for at least 6 h at the method's LOQs. Additional research is needed to define the times of last detection. Controlled cannabis administration provides a scientific database establishing appropriate OF cutoffs and informing test interpretation.

Keywords: Oral Fluid, Tetrahydrocannabinol, Cannabinoids

The First Documented Case with Positive 1-(3-Trifluoromethylphenyl) Piperazine (TFMPP) Results at the Office of the Chief Medical Examiner, City and County of San Francisco, California

Pavlos Karamanidis^{*,1}, Chinyere M. Williams¹, Justin A. Volk¹, Ann M. Gordon¹, Ellen Moffatt¹, Amy P. Hart¹, and Nikolas P. Lemos^{1,2}

¹Office of the Chief Medical Examiner, City and County of San Francisco, CA, USA; ²Department of Laboratory Medicine, School of Medicine, The University of California, San Francisco, CA 94143, USA

Objectives: 1-(3-Trifluoromethylphenyl) piperazine (TFMPP) is a common constituent of a relatively new group of recreational drugs often called ‘party pills’. These recreational substances frequently contain other piperazine derivatives including benzylpiperazine (BZP), and 1-[3-chlorophenyl]-piperazine (mCPP). TFMPP is currently not a scheduled substance and it is legally available to purchase despite the FDA’s temporary listing as Schedule I during its investigation into evidence of TFMPP’s potential harm. Case History: A 23-year-old black female was the victim of multiple gunshot wounds. The victim suffered significant blood loss as a result of her injuries. She was pronounced dead at the scene and was transported to the Office of the Medical Examiner for autopsy. Gunshot residue and other physical evidence were collected as were specimens for toxicology analysis. The objective of this work is to present the first documentation of TFMPP at the Office of the Chief Medical Examiner in San Francisco, CA.

Methods: At autopsy, central/cardiac blood (BL-C), peripheral blood (BL-P) urine (UR) and vitreous humor (VH) were collected. BL-P was screened for volatiles including ethanol, methanol, acetone and isopropanol using headspace gas chromatography flame ionization detection with negative results. BL-C and UR were separately screened using a commercially available enzyme linked immunosorbent assay (ELISA) for amphetamine, methamphetamine, cocaine, opiates, oxycodone, methadone, fentanyl, cannabinoids, phenacyclidine, benzodiazepines, barbiturates, and tricyclic antidepressant drugs (Venture Labs, Inc., Redwood City, CA, USA). BL-C was also screened for common alkaline drugs using gas chromatography mass spectrometry (GC-MS).

Results: Subject showed normal and non-contributory visceral and microscopic findings. Eighteen gunshot wounds were identified representing up to 9 gunshot trajectories. Toxicology screening of BL-C and UR by ELISA necessitated confirmatory/quantitative tests for cannabinoids and amphetamines. The alkaline drug screen by GC-MS in both BL-C and UR indicated presence of TFMPP as well as incidental findings of nicotine, cotinine and caffeine. 3,4-Methylenedioxyamphetamine (MDMA, Ecstasy) and 3,4-Methylenedioxyamphetamine (MDA) were confirmed and quantified in BL-P at concentrations of 0.16 mg/L and 0.01 mg/L, respectively. MDMA and MDA were also confirmed in the decedent’s urine. Due to the victim’s significant hemorrhage at the scene, there was insufficient BL-P volume to confirm/quantify cannabinoids. Consequently, aliquots of BL-C and UR were submitted to a contracted reference laboratory which determined (by GC-MS) the presence of 21 ng/mL of Δ^9 -Tetrahydrocannabinol (THC), 6 ng/mL 11-Hydroxy Δ^9 -Tetrahydrocannabinol (11-OH-THC) and 96 ng/mL of Δ^9 -Carboxy Tetrahydrocannabinol (THC-COOH). THC-COOH was also confirmed present in the victim’s UR. The same reference laboratory measured TFMPP in BL-C and UR at 1.1 mg/L and > 0.5 mg/L, respectively.

Conclusions: Toxicological interpretations of TFMPP in this case are complicated by the decedent suffering from multiple gunshot wounds. Cause of death directly from TFMPP toxicity or overdose cannot be determined.

Key Words: 1-(3-trifluoromethylphenyl) Piperazine (TFMPP), Postmortem, Homicide

Proof of Concept for a Comprehensive Method for Rapid Drug Screening of Whole Blood with UHPLC Accurate-mass TOF LC/MS.

Fessessework Guale^{*1}, Shahriar Shahreza¹, Lynn DeCuir¹, Ashraf Mozayani¹, Tina Chambers², Sue Cohen² and John Hughes³.

¹Harris County Institute of Forensic Sciences, Houston, TX, USA; ²Agilent Technologies, Inc., Lake Forest, CA, ³Agilent Technologies, Inc., Pleasanton, CA, USA

Introduction: Accurate-mass time-of-flight (TOF) LC/MS with fast, high-resolution chromatography using sub-2 μ particle columns has been shown to be a rapid and specific technique for screening for large numbers of target compounds in biological samples. As a TOF instrument is “all-scan, all the time” vs. a quadrupole LC/MS’s SIM or MRM acquisition, effective sample preparation for biological fluids is helpful in reliably and confidently “finding” target drugs and metabolites. The combination of an advanced HPLC method with 3-second retention time reproducibility, along with a TOF MS providing 2-ppm mass accuracy and spectra with isotopic fidelity, across a range of concentrations found in real samples, provides high confidence identification. The criteria for a positive identification include: retention time match to standard, mass match to the target formula, and isotope abundance ratio and mass match figures of merit.

Objectives: The objective of this project was to develop a comprehensive LC/MS-based drug screening method which could replace ELISA screening for many drugs. A relatively simple and efficient sample preparation is a requirement for such an LC/MS method for it to be competitive with or advantageous relative to ELISA for moderate to high volume drug screening in forensic or clinical toxicology.

Materials and Methods: A necessary part of the project was to compare different sample preparation methods for the extraction of fifty abused and prescribed drugs and their metabolites from whole blood. Efficacy of extraction for each drug was measured using cartridge SPE, dispersive pipet-tip SPE, and liquid-liquid extraction (traditional and TOXI-TUBES®). Screening cutoffs of 10, 25, and 1000 ng/mL were evaluated for low and high-dose drugs including benzodiazepines, opiates, stimulants (SMA’s and cocaine), muscle relaxants, analgesics, and barbiturates. Optimized positive and negative ionization methods with the Agilent Jet Stream Technology ESI source were used for optimum detection of this range of compounds.

Results: LC/MS method parameters, figures of merit for retention time and mass measurements used for positive identification, and sample preparation method details are presented along with selectivity and recovery for the most effective sample preparation method.

Key Words: TOF LC/MS, Rapid Drug Screening, Whole Blood

Universal LC-MS Library – Dream or Reality? Use of a New Drug and Metabolite Library Recorded on a LXQ Linear Ion Trap for Drug Screening Using QTrap Instruments

Dirk K. Wissenbach*, Markus R. Meyer, Armin A. Weber and Hans H. Maurer

Department of Experimental & Clinical Toxicology, Saarland University, Homburg (Saar), Germany

Introduction and Objectives: In contrast to universal gas chromatography electron impact mass spectrometry (GC-EI-MS) libraries, current liquid chromatography (LC)-MS libraries are limited to specific mass analyzers. Therefore, this study determined whether a new drug and metabolite library recorded on one instrument, a LXQ linear ion trap (Waltham, MA, USA; Wissenbach et al, Anal Bioanal Chem 2011;400:79; [Epub ahead of print] DOI: 10.1007/s00216-011-5032-1), could be used for drug screening on a different type of instrument, in this case a QTrap.

Materials and Methods: The library was built with MS² and MS³ wideband spectra using a Thermo Fisher LXQ linear ion trap with electrospray ionization in positive mode and full scan information-dependent acquisition. The library now consists of data from >1000 parent compounds and >2,300 metabolites and artifacts (5800 spectra).

The data for the comparison study were recorded after LC separation on a ThermoFisher LXQ with standard settings (Wissenbach et al, see above) and an Applied Biosystems QTrap 3200 (Foster City, CA, USA) with full scan information-dependent acquisition and different MS/MS scan settings (enhanced product-ion [EPI] with 25-30 eV collision energy and EPI 35 eV using collision energy spread [CES] 15). Approximately 50 authentic human urine samples were screened by both instruments and the data were evaluated using the software tool SmileMS (GeneBio, Geneva, Switzerland).

Results: EPI with a fixed collision energy (27 eV was the best choice) led to better match qualities than those with EPI with CES. In the authentic urine samples tested, spectra from approximately 200 different compounds relating to approximately 50 drugs were recorded. Although the software identified approximately 50% of the 200 compounds using QTrap, all drugs with two exceptions (pregabalin and candesartan) were confirmed. This was possible by identification of at least one target (parent drug, metabolite, artifact) out of approximately 5-10 per drug, which illustrated the important addition of metabolites and artifacts to a drug library. Pregabalin and its metabolites were not detected due to difficulty with different Qtrap spectra. The only candesartan target was overlooked according to pattern mismatch, which again displayed the importance of having several targets per drug.

Conclusions: In order to improve future screening results, the software will be optimized for match quality and the library will be expanded to include LXQ composite spectra consisting of MS² and MS³ spectra. Additionally, spectra recorded on a QTrap that did not match the LXQ spectra will be included. In summary, although our results showed that an individual library transfer to other instrument types should be possible; further studies and optimization are needed.

Key Words: Library, LXQ, QTrap

Identification of New Amphetamine-Related Designer Drugs in Drug Seizures by Means of GC-MS, GC-MS After Derivatization With 2,2,2-Trichloroethyl Chloroformate, and U-HPLC/HR-Orbitrap-MS

Giampietro Frison*, Flavio Zancanaro, Luca Zamengo, Maria Gregio, Samuela Frasson, Rocco Sciarro
Laboratory of Environmental Hygiene and Forensic Toxicology, Department of Prevention, Azienda ULSS 12
Veneziana, P.le Giustiniani 11e/2, I-30174 Mestre (Venezia), Italy

Objectives: An increasing number of new amphetamine-related designer drugs, including cathinone derivatives, are appearing on the recreational drug market. They are readily available from "smart shops" and can be purchased over the Internet through many websites which sell them cheaply as "legal" alternatives of controlled amphetamines. Obtaining the structural characterization of these new drugs obtained from police drug seizures has been one of the recent goals of our laboratory.

Materials and Methods: Methanolic solutions of seized tablets or powders were analyzed by Gas Chromatography – Mass Spectrometry (GC-MS), and GC-MS after derivatization with a mixture of 2,2,2-trichloroethyl chloroformate : ethyl acetate (3:7) at 80°C for 15 min. GC-MS analyses were performed on a Agilent 7890 series II/5975 GCMS system in EI full-scan (m/z 40-450) conditions with an Agilent HP-5MS UI (30 m x 0.25 mm, 0.25 μ m film thickness) capillary column. In addition, properly diluted solutions of seized products were analyzed with ultra-high-pressure liquid chromatography – high resolution/high accuracy Orbitrap® mass spectrometry (UHPLC-HRMS) on a Thermo Scientific Accela 1250 UHPLC system equipped with a Hypersil Gold PFP analytical column (2.1 x 50 mm, 1.9 μ m particle size), coupled to a Thermo Scientific single-stage Exactive HCD MS system, interfaced with an HESI-II source, operating from m/z 50 to 800 and mass resolution of 25.000 (HCD on, 25 eV) or 100.000 (HCD off).

Results: Due to the poor chromatography and relatively non-specific EI mass spectra obtained with GC-MS analysis of the underivatized drugs, a straightforward and relatively rapid derivatization with 2,2,2-trichloroethylchloroformate was employed. This led to improved GC properties and distinctive MS behaviour of derivatives resulting in highly informative EI mass spectra. For example, underivatized mephedrone showed a mass spectrum with a barely visible molecular ion at m/z 177, a base peak at m/z 58, less abundant fragment ions at m/z 119, 91, 65, 56, 162. Derivatization allowed us to obtain a great enhancement of the molecular weight of the original analyte (from 177 to 351) with a mass spectrum characterized by molecular (m/z 351-353-355) and various fragment ions (i.e m/z 232 – 234 – 236) with characteristic isotopic clusters. Moreover, the application of UHPLC-HRMS, with a benchtop Orbitrap® MS system, allowing for accurate mass measurements at 100.000 resolving power, greatly enhanced analytical capabilities in structural characterization of new designer drugs. For example, exact mass of mephedrone ($C_{11}H_{15}NO$) MH^+ ionic species is 178,1226 and measured accurate mass was 178,1225, with a mass accuracy of -0,56 ppm. In addition, experimental and calculated mephedrone MH^+ isotopic clusters were fully superimposable, both qualitatively and quantitatively. Lastly, the contribution of ^{13}C , 2H , ^{15}N , ^{18}O isotopes produced measured relative isotopic abundances of the (M+1), (M+2) and (M+3) mephedrone isotopic clusters, relative to the monoisotopic (M+0) cluster, completely in accordance with theoretical values.

Conclusions: By means of the described analytical techniques the identification of mephedrone, 4-methylethcathinone, methylenedioxypropylvalerone, methylone, 4-fluoroamphetamine, chlorophenylpiperazine and other amphetamine-related designer drugs was achieved, in spite of poor availability of reference standards.

Key Words: Cathinones, Mass Spectrometry, Orbitrap®.

Qualitative and Quantitative Analysis of 4-Methylmethcathinone (mephedrone) by DESI-MS

Natasha Stojanovska^{1*}, Shanlin Fu¹, Mark Tahtouh², Tamsin Kelly³ and Alison Beavis¹

¹University of Technology, Sydney (UTS), NSW, Australia; ²Australian Federal Police (AFP), NSW, Australia; ³University of Canberra (UC), Australia

Objectives: The aim of this study was to develop a qualitative and quantitative method for the analysis of novel drug analogues in drug materials such as 4-methylmethcathinone (mephedrone) using Desorption Electrospray Ionisation – Mass Spectrometry (DESI-MS). Once developed the DESI-MS method was compared to current profiling techniques such as Gas Chromatography – Mass Spectrometry (GC-MS) and Liquid Chromatography – Mass Spectrometry (LC-MS).

Methods: DESI-MS experiments were performed on an Agilent 6500 series Accurate-Mass Q-TOF mass spectrometer equipped with a Prosolia DESI ion source in positive ion mode. The spray solvent was a mixture of methanol and water (1:1) containing 1% formic acid. Codeine-d₆, (as an internal standard) was prepared in the spray solvent at a final concentration of 0.25 µg/mL. Methanolic solution of each sample (2 µL) was applied to a Teflon surface and was allowed to dry prior to DESI-MS analysis. The same Q-TOF mass spectrometer was configured with an ESI source and an Agilent 1200 series LC system for LC-MS analysis. LC separation of analytes was achieved on a Phenomenex C18 column and the MS was operated in full scan mode. GC-MS analysis was carried out on an Agilent 7890A/5975 GC-MS equipped with a HP-5MS column in full scan mode. Codeine-d₆ was used as the internal standard for all three techniques. Samples containing mephedrone were prepared by four different synthetic methods and were labelled as Meow 1 to Meow 4 correspondingly. The purity of mephedrone in these preparations was assessed by applying the analytical methods developed above.

Results: The linear ranges tested for each technique were as follows: DESI-MS 50-800 µg/mL, GC-MS 5-400 µg/mL, and LC-MS 0.1-6 µg/mL with coefficients of determination (R²) of 0.984, 0.999 and 0.998, respectively. In DESI-MS analysis, the intra- and inter-day precision, based on the percentage relative standard deviation (%RSD), was between 25-34%. The intra- and inter-day accuracy, expressed as percentage mean relative error (%RE), was between 8-27%. The intra- and inter-day accuracy and precision obtained from DESI-MS is larger than that of GC-MS and LC-MS (%RSD <15%, %RE <20%), due to the nature of the technique and in particular DESI's transient signal response. When applied to the four synthesized mephedrone samples, all three methods gave comparable purity results. In addition, DESI-MS analysis was successful in identifying an impurity of synthesis, triethylamine, in Meow 3 and Meow 4 that was undetectable by GC-MS and LC-MS analyses.

Discussion: DESI-MS is known to suffer from ion suppression and lack of sensitivity as compared to the current confirmatory techniques such as GC-MS and LC-MS; however it is advantageous in that it requires little sample preparation and requires less than 1 minute to analyse a single sample. Therefore, DESI-MS is a great technique for preliminary analysis of novel drug analogues such as mephedrone and has advantages over other screening tools. Its quantitative abilities suggest that one instrument could potentially be used for preliminary qualitative and quantitative analysis of drug analytes simultaneously.

Conclusion: When a low detection limit is not required, DESI-MS was shown to be a viable technique for qualitative and quantitative analysis of mephedrone. Work is underway to demonstrate this technique on other novel drug analogues.

Key Words: DESI-MS, 4-Methylmethcathinone (Mephedrone), Novel drug Analogues

Death by “Bath Salts”: Postmortem Tissue Distribution of MDPV Following Lethal Intoxication

J. F. Wyman^{*1}, E. S. Lavins¹, S. Sofalvi¹, E. J. Armstrong¹, D. A. Engelhart², P. D. Boggs¹, S. M. Taylor¹, C. K. Naso¹, J. M. Stibley¹, K. D. Snell¹, L. D. Wilkins¹, K. M. Gubanich¹, C. D. Mazzola¹, R. N. Norris³, L.M. Blum⁴ and F. P. Miller¹
¹Cuyahoga County Regional Forensic Science Laboratory, Cuyahoga County Medical Examiner, Cleveland, OH, USA; ²Omega Laboratories, Mogadore, OH, USA, ³University of Toledo, Toledo, OH, USA, ⁴NMS Labs, 3701 Welsh Road, Willow Grove, PA, USA.

Introduction: MDPV (3,4-methylenedioxypropylvalerone) is a psychoactive, synthetic analog of the CNS stimulants cathinone and pyrovalerone. MDPV, along with other “bath salt” cathinones (methylenedioxymethamphetamine and mephedrone), recently achieved “epidemic” status for abuse by young people. MDPV may exert its pharmacologic effect by inhibiting the reuptake of dopamine and norepinephrine. Toxicities observed include tachycardia, hypertension (vasoconstriction), insomnia, hyperthermia, mydriasis, panic attack, seizures, and aggressive behavior.

Case History: A 39-year-old white male with a history of schizophrenia, depression, and drug abuse was last known alive about 4.5 h prior to being found dead, supine in bed. It was known by family members that he had begun snorting “bath salts”. All indications were that his exposure to “bath salts” occurred following the time he was last seen. A collection of “bath salts” and packages of synthetic cannabinoids were found with the body. Empty jars of “TranQuility” and “Infinity” concentrated “bath salts” were present in a trash can near the body. Packages of “Demon” and Flame™, synthetic cannabinoids, were also at the scene.

Autopsy Findings: Autopsy findings were unremarkable except for a mildly enlarged heart (430 g), moderate vascular congestion, and pulmonary edema (right lung 950 g, left lung 710 g). Multiple specimens were collected and analyzed as indicated in the table below.

Materials and Methods: MDPV was extracted using UCT Clean Screen ZSDAU020 extraction columns using a previously published basic drug UCT extraction procedure. Analytes were separated and detected by an Agilent GC/EI-MS with a Zebtron ZB-50 capillary column.

Results: The concentrations of MDPV in tissues are shown in the table below:

Specimen Conc. (mg/L) or (mg/kg)	Femoral Blood	Heart Blood	Urine	Gastric per 50 mls	Bile	CSF	Lung	Kidney	Liver	Heart
	0.44	0.50	>5.0	> 0.1 mg	0.88	0.41	0.60	0.84	0.98	0.12

Muscle (psoas)	Spleen	Brain (parietal)	Brain (cerebellum)	Brain (lenticular nucleus)	Brain (frontal)	Brain (occipital)	Brain (medulla)	Hair
0.56	0.64	0.36	0.42	0.30	0.30	0.42	0.42	Not Detected

Other femoral blood and urine results were: caffeine, fluoxetine (0.29 mg/L in blood), lamotrigine (0.41 µg/mL), and JWH-18 and -250 (0.48 and 4.6 ng/mL, resp.). Nicotine, cotinine, pseudo/ephedrine, m-chlorophenylpiperazine and methylenedioxymethamphetamine were present in urine only.

Conclusions: MDPV was distributed among multiple tissues with values ranging from 0.12 mg/L (heart) to 0.98 mg/L (liver). The heart: peripheral blood ratio gave no clear indication that MDPV undergoes postmortem redistribution. Tissues/fluids responsible for detoxification/ excretion had higher concentrations of MDPV. MDPV was present in all samples analyzed except hair. Its absence from hair was consistent with the suspicion that this was an acute exposure to MDPV. The cause of death was ruled acute MDPV intoxication.

Key Words: Bath Salts, MDPV, Postmortem

O91

New trips on the Block – A Retrospective Study in Hair

K.Y. Rust*, A.M. Dally, M.R. Baumgartner and T. Kraemer
Institute of Legal Medicine, University of Zurich, Zurich, Switzerland;

Objectives: New designer drugs are conquering the drug scene. Piperazines and cathinones seem to prevail the ecstasy market. But little is known about the actual prevalence of these drugs. Reanalysis of hair samples from routine cases concerning the presence of new designer or “smart drugs” should provide insight into changing patterns of designer drugs.

Materials and Methods: All hair samples from 2010 that originally tested positive for amphetamines or MDMA in the authors’ hair lab (N = 200) were reanalyzed for new or smart drugs such as 4-fluoroamphetamine, piperazines (BZP, mCPP and TFMPP), cathinones (4-MMC (mephedrone), methylone, butylone, ethylone, methcathinone and cathinone), methylphenidate and ketamine. Hair snippets were extracted using a two step extraction procedure. The analytes were separated using a Dionex UltiMate 3000 HPLC-System with a PFP separation column (Phenomenex Kinetex, 2.6 µm, 50/2.1), gradient elution with a mobile phase of 5 mM ammonium formate buffer pH3/methanol with ammonium formate buffer and a total flow of 0.5 mL/min. Drugs were detected with an AB Sciex 5500 Q-Trap LC-MS/MS system (ESI, MRM-IDA-EPI).

Results: Concerning the piperazine drugs, mCPP was positive in 8% of cases and TFMPP in one case. Some mCPP cases were also positive for trazodone, an antidepressant metabolized to mCPP. In 5% of all cases 4-MMC was positive, cathinone was positive in 3 cases. Concerning “smart drugs”, methylphenidate was found in 4.5% of cases and 10% were positive for ketamine. 4-Fluoroamphetamine was identified in 1.5% of cases.

Conclusion: New designer drugs are definitely in use. More studies are necessary (e.g. on other groups of users) to assess the overall prevalence of new and smart drugs in the population.

Key Words: New Drugs; Hair Analysis; LC-MS

Studies on the CYP Isoform-Dependent Metabolism of the Cathinone-Derived Designer Drugs 3-Fluoromethcathinone and 3-Bromomethcathinone Using LC-HRMS

Markus R. Meyer^{*1}, Christian Vollmar¹, Andrea E. Schwaninger¹, Ehud (Udi) Wolf², and Hans H. Maurer¹

¹Dept. of Exper. & Clin. Toxicology, Saarland University, Homburg (Saar), Germany; ²Division of Identification & Forensic Science, Israel Police HQ, Jerusalem, Israel

Objectives: 3-fluoromethcathinone (3FMC) and 3-bromomethcathinone (3BMC) are two novel cathinone-derived designer drugs which have recently appeared on the recreational drug market in e.g. Israel and Germany. The aims of this study were to assess the metabolic involvement of the ten most important cytochrome P450 (CYP) isozymes and to determine kinetic parameters using metabolite formation assays.

Materials and Methods: Activity screenings for general involvement of the ten most important individual cDNA expressed CYPs in the initial metabolic reactions of 3FMC and 3BMC were performed using baculovirus infected insect cell microsomes (Gentest) as enzyme sources. Affinity constants (K_m) were determined using the aforementioned enzymes and pooled human liver microsomes (HLM). After terminating the incubations with acetonitrile and centrifugation, the supernatants were directly analyzed using a ThermoFisher Exactive HRMS system, after separation on an Alltech Mixed-Mode/Cation exchange column (150 mm x 4.6 mm I.D.) with a mobile phase consisting of ammonium formate buffer pH 3.5 and acetonitrile at a flow rate of 0.5 to 0.75 mL⁻¹. The analytes were detected by positive ESI in the full-scan mode with and without HCD (Higher Energy Collisional Dissociation) "All Ion Fragmentation".

Results and Conclusions: The formation of N-demethyl 3FMC was markedly catalyzed by CYP2B6, CYP2C19, and CYP2D6 whereas the N-demethylation of 3BMC was catalyzed by CYP2B6 and CYP2D6. Furthermore, formation of 3FMC N-oxide was observed in incubations of CYP2B6 and CYP2C19. Product formation kinetics in HLM for 3FMC were best described with a biphasic model whereas the product formation kinetics of 3BMC followed classical Michaelis-Menten kinetics. Among the specific isozyme-dependent reactions, the N-dealkylation was shown to be the reaction with the highest CYP isozyme affinity described with K_m values of 283 μ M (CYP2B6), 76 μ M (CYP2C19), and 12 μ M (CYP2D6) for 3FMC and 18 μ M (CYP2B6) and 350 μ M (CYP2D6) for 3BMC.

Key Words: Cathinones, Cytochrome, Metabolism

A Dual Approach to the Unequivocal Diagnosis of Botulinum Toxin Exposure

Marcel van der Schans*, Marloes Joosen, Roland van den Berg, Daan Noort, Jan Langenberg
TNO CBRN Protection, Rijswijk, The Netherlands

Objectives: The extreme toxicity of botulinum toxin makes this agent a likely candidate for use in deliberate intoxications, terrorist attacks or biological warfare, with exposure by ingestion or respiratory exposure with aerosols being the most likely scenarios. Unequivocal verification of botulinum toxin exposure has always been difficult, because of the lack of sensitive assays for measuring the low toxin concentrations at the effect level. With the advent of two new technologies, the Endopep and electrochemiluminescence methods, new opportunities to study the fate and kinetics of botulinum toxins have arisen.

Materials and Methods: The Endopep method is based on the cleavage of specific substrate peptides by the protease activity of botulinum toxin. The amino acid sequences of the assay peptides were inspired by the SNARE proteins of the synapse that are cleaved by the toxin *in vivo*. The resulting substrate peptide fragments are analyzed with LC-MS, MALDI-TOF or capillary electrophoresis laser induced fluorescence (CE-LIF). The method is sufficiently sensitive to detect approximately 1 pg of Botulinum toxin A and B forms. When the toxin needs to be determined in plasma or any other biological matrix, the toxin was extracted with antibody loaded magnetic beads to exclude non-specific protease activity, followed by incubation in the EndoPep assay. The electrochemiluminescence method, a sandwich immunoassay with a Ruthenium labeled second detection antibody, showed approximately the same detection limits. The utility of these methods was exemplified by studying the intravenous toxicokinetics of botulinum toxin A and B in rats, which will serve as a measure for 100% bioavailability. Additionally, we measured the toxin levels in liver, spleen, kidney, brain and diaphragm to obtain more insight in the distribution of the agent across the body. The *i.v.* dose was 120 ng/kg and 30 ng/kg per animal and C_{max} was 2.5 ng/mL and 0.7 ng/mL for B. toxin A and B respectively.

Results and Conclusions: Both toxins appeared to be very persistent. Half life of the toxin was approximately 6 h, however most of the toxin was recovered in the tissues (except for the brain) at 6 h after the injection, which points to a very slow elimination. Subsequently, the toxicokinetics of Botulinum toxin A and B in blood were determined after exposure by ingestion or by intra-tracheal administration of botulinum toxin aerosols as a substitute for respiratory exposure. In conclusion, we envisage that the combined use of the Endopep and electrochemiluminescence methods open up the way for diagnostic assays at the botulinum toxin effect level, which holds great promise for forensic applications.

Key Words: Botulinum Toxin, Toxicokinetics, Rats

Specific and Rapid Detection of Drugs from Oral Fluid Using Paper Spray Ionization Tandem Mass Spectrometry

Mark C. Parkin^{1,*}, Eleanor Menzies², Andrew Kicman¹, Anna Milsom³, Samantha Ollerton³, Richard Sleeman³ and Felicia Green²

¹Department of Forensic Science & Drug Monitoring, King's College London, 150 Stamford Street, London SE1 9NH, England, UK; ²National Physical Laboratory, Hampton Road, Teddington, TW11 0LW, England, UK; ³Mass Spec Analytical Ltd, Building 20F, Golf Course Lane, Filton, Bristol, BS34 7RP, England UK

Objectives: To demonstrate proof of concept for a novel mass spectrometry based multi-drug detection device to be used by police in the station for evidence supporting enforcement of drug driving legislation. Recently, the use of paper spray ionization was demonstrated as a variant of electrospray ionization for the direct detection of drugs in biological samples. This approach involved depositing samples onto paper and after application of a small amount of solvent and a high voltage, charged droplets containing the analyte are released from the paper and transportation and ionization by the electrospray process occurs. The methodology developed in this work utilizes paper spray ionization to analyse synthetic oral fluid samples directly for drugs, reducing analysis time to just a few minutes and providing a means for simple, multi-drug detection that could be used as a screening device for oral fluid in a police station.

Materials and Methods: Sixteen target drug solutions containing 10–50 ng/mL cannabinoids, benzodiazepines, cocaine, amphetamine, methylamphetamine, methadone and opiates were prepared using synthetic oral fluid. A 10 mm by 20 mm paper triangle cut from Whatman Chromatography paper was wet with 30 μ L of target drug in synthetic oral fluid together with 30 μ L of methanol (0.1% formic acid). A voltage of 4.5 kV was applied to the paper and spectra were acquired between 1 and 2 minutes on an Applied Biosystems QSTAR Elite hybrid mass spectrometer. Poly-drug solutions were also prepared to investigate the synthetic oral fluid samples containing up to 7 individual drug components.

Results: Using paper spray ionization coupled to tandem mass spectrometry eleven out of sixteen target drugs in synthetic oral fluid were detected at cut-off levels suitable for the screening of drugs used for transport law enforcement in the UK. In addition, simultaneous detection of up to 7 drugs from within poly-drug mixtures with no interferences from substances such as cigarette smoke or caffeine was achieved.

Conclusions: Paper spray ionization coupled to tandem mass spectrometry was successfully demonstrated as a proof of concept for the rapid and specific detection of drugs in oral fluid. The methodology developed reduces analysis time without the need for any sample preparation or separation.

Key Words: Paper Spray Ionization, Oral Fluid, Poly-Drug Detection, Drugs and Driving

Street Drug Availability – The Impact on Toxicology Laboratories**Peter Akrell***

Concateno, Abingdon, Oxfordshire, UK

Objectives: Media reports during November 2010 indicated that a drought affected the opium poppy harvest in Afghanistan and Pakistan, resulting in a shortage of heroin on the streets of the UK. Anecdotal reports also indicated that heroin was also heavily adulterated to reduce purity. Internet drug user forums had posts indicating that heroin users were getting desperate due to low heroin availability or quality. We present oral fluid results from drug addicts collected during this heroin shortage.

Materials and Methods: The data presented are the results of opiates analysis of 800,000 oral fluid samples at our Abingdon, UK laboratory between January 2009 and March 2011. Oral fluid samples were collected using the Concateno Certus, Cozart Oral Swab and Orasure Intercept collectors and analysed by Microgenics CEDIA, Cozart ELISA or Orasure ELISA immunoassays or directly by GC-MS with no prior screening analysis. Codeine, morphine, 6-acetylmorphine and dihydrocodeine were analysed by GC-MS. On average, 30,000 samples per month were submitted to the laboratory for analysis from drug addiction treatment clinics and drug related probation services from across the whole of the UK.

Results: The monthly mean positivity rate for opiates was 45% (range 41% – 48%) between January 2009 and October 2010. The opiate mean positivity rate for November 2010 decreased to 30% and again in December 2010 to 22%. This lower positivity rate continued at 21%, 20% and 22% for January, February and March 2011, respectively.

Samples were also analyzed for a variety of other drugs as requested by the customers. The proportion of samples analysed for each drug group were: cocaine (70%), benzodiazepines (45%), methadone (45%), amphetamines (30%), cannabis (20%), buprenorphine (12%), and anhydroecgonine methyl ester (AEME; 10%). Positivity rates for these drug groups showed no significant changes during the analysis period, with 20% of samples positive for cocaine, 30% for benzodiazepines, 75% for methadone, 10% for amphetamines, 10% for cannabis, 50% for buprenorphine and 10% for AEME.

Reports from hospital accident and emergency departments indicated that what was sold as ‘heroin’ on the streets contained substantial amounts of benzodiazepines. No increase in the benzodiazepine positivity rate was seen in analysed samples, but this may be because less than half of the samples were tested for benzodiazepines.

Conclusions: Since this effect was seen across different collection devices, different immunoassay techniques and by GC-MS, it suggests that this effect is not due to a particular collection device or analytical method. A drop in the availability of street heroin and a significant decrease in the purity may be detected through the analysis of oral fluid samples within a toxicology laboratory due to the shorter window of detection for drugs in oral fluid.

Key Words: Heroin Drought, Opiates, Oral Fluid

Fast and Efficient Quantification of 31 Common Drugs of Abuse and Benzodiazepines in Whole Blood Using Fully Automated Sample Preparation and UPLC-MS/MS

Brian Schou Rasmussen*, Kirsten Wiese Simonsen, Stella Røgn Sigurdardottir, Petur Weihe Dalgaard, David Wederkinck Andersen, Marie Kjærgaard Bjørk, Kristian Linnet
Section of Forensic Chemistry, Department of Forensic Medicine, Faculty of Health Sciences, University of Copenhagen, Copenhagen, Denmark

Objectives: Sample preparation is a time consuming and costly step in modern forensic analytical methods. Automation not only has the potential to save time and money, but also to increase reproducibility, robustness and traceability. We have designed and implemented an advanced robotic setup capable of doing all steps typically involved in advanced sample preparations needed for biological matrices in forensic toxicology. Here we present a fully validated method for the analysis of 31 common drugs of abuse and benzodiazepines in both living subjects and post mortem whole blood. Whole blood samples are processed offline in batches of up to 96 on a Tecan robotic platform via solid phase extraction (SPE) followed by rapid analysis on a ultra performance liquid chromatograph-mass spectrometer/mass spectrometer (UPLC-MS/MS).

Methods: The automated SPEs were performed on a Tecan Freedom EVO 200 robot equipped with liquid handling arm working with disposable tips, robotic manipulator for plate movements, plate shaker and vacuum station for SPE. Furthermore the robotic system was equipped with an integrated barcode reader, centrifuge, evaporator and plate sealer. SPE was performed using Phenomenex Strata X-C columns and chromatography using a 100 mm × 2.1 mm, 1.7 μm Waters Acquity CSH C18 column with a 6.5 min gradient using water/methanol with ammonia. LC-MS/MS instrumentation consisted of a Waters Acquity UPLC and a Waters Quattro Premier XE triple quadrupole MS. Up to 96 samples can be fully prepared in less than 3 hours including all steps starting with confirmation of sample identity by barcode reading on primary or secondary blood tubes, weighing of blood aliquots along with transfer to a 96 well format. Calibrators are automatically spiked in blank matrix and a mixture of 28 deuterated internal standards added. This is followed by dilution of whole blood samples and centrifugation before SPE of the supernatant. After SPE the eluate is evaporated and reconstituted. Finally, a 96 well plate with all extracts and controls is analyzed on UPLC-MS/MS. On average only 30 minutes is spent per batch by a laboratory technician, who sets up the robot with samples, solvents etc. and cleaning afterwards. This is a significant time reduction compared to manual or semi-automatic methods. Tight software integration with LIMS has eliminated manual transfer of results and files, further increasing traceability and efficiency.

Results: The method was fully validated with lower limits of quantification ranging from 0.002 to 0.005 mg/kg and upper limits of quantification of 1.0 mg/kg. CV at LOQ were below 20% and accuracy were between 80-120% at LOQ and 85-115% above. Recoveries were above 80% for 22 compounds and 40-60% for the remaining 9 compounds. The effects of automating and before standardization are also seen on the long-term precision, which is in the range of 3 to 10%, significantly lower than our previous semi-automatic methods.

Conclusion: Complete offline automation of sample preparation has proven both fast and efficient and robust in routine analysis and has eliminated most gross human error and increased traceability.

Key Words: Drugs of Abuse, Whole Blood, Automation

2-Nitro-MAM and 2-Nitro-Morphine: Potential Markers for Monitoring the Presence of Opiates in Urine Adulterated with Potassium NitriteSusan Luong^{*1}, Shanlin Fu¹, James Hook²¹University of Technology, Sydney (UTS), NSW, Australia; ²University of New South Wales (UNSW), Sydney, NSW, Australia

Objectives: 6-monoacetylmorphine (6-MAM), morphine and codeine are opiates routinely tested in urine samples to monitor heroin use. However, it has been well documented in literature that these opiates are prone to destruction by some in-vitro oxidising urinary adulterants such as potassium nitrite (KNO_2) producing false negative test results. The objectives of this study were to expose 6-MAM, morphine and codeine in urine to potassium nitrite and to identify stable oxidation products formed in the reaction systems, which may ultimately be used for monitoring heroin abuse despite urine adulteration with nitrite.

Materials and Methods: KNO_2 was added to samples spiked with 10 $\mu\text{g/mL}$ 6-MAM, morphine or codeine in both water and blank urine, at a final KNO_2 concentration of 0.05M and 0.6M. The reaction mixtures were adjusted to a pH range of 3 to 8, and left at room temperature for varying periods. LC/MS-MS analysis of these reaction mixtures was then carried out on the Agilent Technologies 1290 LC system coupled with the Agilent 6460 QQQ-MS detector. Chromatographic separation was achieved using an Agilent Zorbax Eclipse Plus C18 Rapid Resolution HD column (2.1 mm \times 50 mm \times 1.8 μm). MS was operated in positive electrospray ionisation (ESI) mode. Full scan, product ion scan and selected reaction monitoring (SRM) were used with an optimal fragmentor energy range of 160-200V and a collision energy range of 35-45eV for all analytes monitored. Stable oxidation products identified from pH and time course studies were synthesised in water in bulk using approximately 10 mg of opiate starting material, and extracted from the aqueous medium with dichloromethane. These isolated residues were used for structural elucidation by conducting High Resolution NMR Spectroscopy experiments (¹H-NMR, COSY, NOESY, HSQC, HMBC), FTIR as well as GC-MS analysis after forming trimethylsilyl (TMS) derivatives.

Results: Reaction of 6-MAM with nitrite yielded a single oxidation product only under acidic conditions. The product was determined to be 2-nitro-6-monoacetylmorphine (2-nitro-MAM) based on data collected from MS, NMR and FTIR experiments. 2-nitro-MAM appeared to be stable in urine (pH < 7) for at least ten days. Similarly, exposure of nitrite to morphine yielded a single major oxidation product, 2-nitro-morphine. In contrast, codeine was unaffected by nitrite under the same experimental conditions. TMS derivatives of 2-nitro-MAM and 2-nitro-morphine could be detected using GC-MS.

Conclusion: Upon exposure to nitrite in urine (pH < 7), 6-MAM and morphine are converted to their respective stable oxidation products, 2-nitro-MAM and 2-nitro-morphine. Quantitative kinetic studies, CEDIA cross reactivity studies and the analysis of adulterated authentic samples are currently underway to further evaluate their viability as markers for monitoring the presence of opiates in nitrite adulterated urine.

Key Words: Opiates, Adulteration, Nitrite.

Are Negative Screen Results Due to “Below Cut-Off” Levels Really Negative?

Anthony Wong^{*1}, Ovandir A. Silva² and Nadia Tawil²

¹School of Medicine-University of Sao Paulo, Brazil; ²Maxilabor Diagnosticos, Sao Paulo, Brazil.

Introduction: Workplace drug testing has been a hallmark in promoting health and preventing accidents. Screening cutoff levels in urine samples determine if confirmatory mass-spectrometry analysis should be conducted. Cutoff results are subject to variations such as time of use, “quality” of the drug and analytical procedures. A “negative below cutoff” level can help a candidate or worker “get off the hook”, and eventual termination, but can produce dubious or conflicting signaling in drug prevention programs. Maxilabor Diagnosticos is the only drug testing laboratory in Brazil that is ISO 17025 certified. It also manages drug programs that emphasize drug awareness and prevention, psychological evaluation and support. In Brazil, most companies provide rehabilitation opportunities instead of termination.

Methods: Between January 2006 and February 2011, a total of 110,874 urine samples from all regions of Brazil were tested for drugs, with positive above cutoff screens in 3357 samples (3.02%). An additional 604 samples had detectable drugs below cutoff limits. Screen analyses were performed using the enzyme immunoassay (Siemens Dimension X-pand and RXL). All samples with detectable drugs regardless of cutoff standards were submitted to confirmation by GC-MS (Agilent Technologies 6890/5973N). The screen cutoff levels were: 50ng/mL for cannabinoids, 300ng/mL for benzoylecgonine and 1000ng/mL for amphetamines. Opioids were seldom detected in our group. The confirmatory cutoff levels were: 15 ng/mL for Δ^9 tetrahydrocannabinol-9-carboxylic acid (THC), 150 ng/mL for benzoylecgonine and 500 ng/mL for the amphetamines/methamphetamines.

Results: A total of 604 samples were below screen cutoff values. These were then submitted to confirmatory analyses. The distribution was as follows: For THC, 341 samples were submitted to confirmation analysis: 129 had values above confirmatory cutoff levels (37.83%), 122 others were below cutoff levels but above the LOQ (35.78%) and 90 were negative for THC. For benzoylecgonine, 227 were submitted to confirmation: 77 had values above confirmatory cutoff values, 87 were below the cutoff values but above the LOQ (38.33%) and 63 were negative (27.75%). For amphetamines/methamphetamines, 36 samples were submitted to confirmatory evaluation: 20 were confirmed positive above cutoff values (55.55%) and 16 were negative (44.45%). Thus, 435 additional samples were actually positive, bringing the total to 3792 (3.48%).

Discussion and Conclusions: Nearly 20% of would be negative specimens were actually positive. The express number of “falsely negative” results that were actually above the confirmatory cutoff values appears to indicate that a significant number of workers are abusing illegal drugs and should have been submitted to disciplinary or therapeutic measures. Early interventions in these cases result in effective recoveries of the drug users. In workplace drug control programs that emphasize rehabilitation, the increased effectiveness with more positive drug detection lends greater credibility to these programs and provides effective tools for early interventions. But basically, what is significance and credibility of cutoff levels in this era of more precise equipment and technologically advanced methodologies when recovery of drug users should be the key issue? Our data in Brazil have shown an over 80% recovery of the drug users in the workplace resulted from early detection, increased confidence in the diagnostic tools and a comprehensive sympathetic approach.

Key Words: Urine Screen Cutoff, Drug Confirmatory Analysis, Workplace Drug Test

Postmortem Peripheral Blood Fentanyl Concentrations in 20 Cases: Analysis and Comparison to Prior Studies**Derrick D. Lung**^{*1}, Patil Armenian¹, Ann M. Gordon², Thomas E. Kearney¹, and Nikolas P. Lemos^{2,3}¹California Poison Control System, San Francisco Division, The University of California, San Francisco, CA, USA; ²Office of the Chief Medical Examiner, City and County of San Francisco, San Francisco, CA, USA; ³Department of Laboratory Medicine, School of Medicine, The University of California, San Francisco, CA 94143, USA

Objectives: This study aims to increase current data published on postmortem peripheral blood (PB) fentanyl concentrations. Our primary goal was to compare PB fentanyl concentrations between deaths caused by fentanyl and deaths in which fentanyl was determined to be an incidental finding. We compared our data to the only prior studies that specify use of PB specimens, by Anderson and Muto *J Anal Toxicol* (2000), and Olson et al *Clin Chem* (2010). Furthermore, we describe observed PB concentrations in fentanyl-caused deaths with and without transdermal (TD) fentanyl use.

Materials and Methods: The San Francisco Office of the Chief Medical Examiner accepted jurisdiction over 3726 postmortem cases from July 1, 2007 to June 30, 2010. A commercially available enzyme linked immunosorbent assay which included fentanyl was performed on central/cardiac blood from 2148 cases as part of the routine drug screening protocol. Fentanyl was detected in 37 cases. Following alkaline (liquid-liquid) drug extraction of PB from the first 10 mL blood aliquot drawn from subclavian or femoral veins collected at autopsy, confirmations and quantitation of fentanyl were performed by gas chromatography/mass spectrometry (Agilent 5973 GC/MSD) in SIM mode. The method is linear from 2.5 to 100 ng/mL. Twenty cases had quantifiable PB fentanyl concentrations.

Results: Of the 20 cases, 13 were determined to be fentanyl-caused deaths. Eight of these 13 cases involved TD fentanyl. The remaining 7 cases were decedents who were undergoing therapy with fentanyl either TD (3) or IV (4). In the 13 fentanyl-caused deaths, PB fentanyl concentrations had a mean of 30.1 (SD 23.1) ng/mL, and ranged from 5 to 79 ng/mL. In the deaths involving TD fentanyl use, the mean fentanyl concentration was 41.7 (SD 25.3) ng/mL, with a range from 5 to 79 ng/mL. Deaths without TD fentanyl use had a mean fentanyl concentration of 21.3 (SD 13.1) ng/mL, and ranged from 5 to 39 ng/mL. These concentrations were on average higher as compared to the concentrations measured in decedents receiving therapeutic fentanyl, in which the fentanyl was determined to be an incidental finding. There were 7 such cases and in 3 of these in which therapeutic TD fentanyl was used, PB concentrations had a mean of 16.6 (SD 11.1) ng/mL, with a range from 4.9 to 27 ng/mL. In the remaining 4 deaths in which therapeutic IV fentanyl was employed, PB concentrations had a mean of 8.1 (SD 5.47) ng/mL, and a range from 3.2 to 15 ng/mL.

Conclusions: Data from our study, similar to the prior cited studies, demonstrate that a PB fentanyl concentration equal to or greater than 25 ng/mL indicates that fentanyl should be considered as being contributory to or the cause of death. However, ranges of measured PB concentrations are once again shown to overlap between subjects who overdose and those who use fentanyl as prescribed. Secondly, fentanyl-caused deaths involving TD fentanyl exposure have higher PB fentanyl concentrations than those who did not use transdermal patches. While this study only reviews 20 cases involving fentanyl in a three-year period in San Francisco, it comprises over a third of all published postmortem peripheral blood fentanyl cases, and strongly suggests further study of fentanyl concentration variability among different postmortem blood specimens.

Key Words: Fentanyl, Postmortem Peripheral Blood, Transdermal Patch

A Family Tragedy After Three Doses of Tylenol

Walter Martz^{*,1} and Craig M. Litwin²

¹Provincial Toxicology Centre, Vancouver BC, Canada; ²Royal Columbian Hospital, New Westminster BC, Canada

Case Report: This report involves the death of a 6 year old female in foster care with a history of cortical blindness and cerebral palsy. She was admitted to a hospital for bilateral leg tendon release surgery and was given 25 mg of codeine/350 mg acetaminophen before discharge to home for pain relief. No urine output was noted during her hospitalization or following discharge to home. The foster parents were advised to continue administering a syrup containing codeine/acetaminophen. The child was found dead in early morning hours of the next day. Autopsy revealed evidence of acute tubular necrosis of the kidneys but no other anatomic abnormalities sufficient to account for death. A systematic toxicological analysis performed after autopsy detected a potentially life-threatening concentration of codeine and an elevated level of acetaminophen. In conjunction with the findings from the autopsy concerning liver and kidney function a critical question was whether the detected codeine concentration could be solely attributed to the two prescribed doses of codeine administered at home by her caregiver in addition to the one hospital-administered codeine dose.

Methods: The death was investigated and the autopsy was performed under the authority of the British Columbia Coroners Service. Femoral and aortic blood, stomach contents and vitreous fluid were recovered at autopsy. Furthermore the bottle containing the remaining syrup was submitted for analysis. The blood was subjected to full drug screening encompassing ethanol as well as both acidic and basic drugs. Instrumentation included gas chromatography, liquid chromatography as well as mass spectral analysis by both GCMS and LCMS. In addition, selected drugs specified in the coroners report were quantitated using accepted standard operating procedures. A pharmacokinetic model for an oral administration of drugs (Bateman function) was used for an estimation of a potentially altered dose-concentration relationship of codeine.

Results: At autopsy the body appeared well cared for with evidence of recent bilateral leg surgery. There was symmetric decreased muscle bulk. Examination of the brain revealed marked hydrocephalus, extensive gliosis and evidence of remote intraparenchymal hemorrhage. Examination of the kidneys revealed microscopic changes consistent with acute tubular necrosis. The liver was grossly and microscopically unremarkable. No solid type medication residue was discernable within the gastrointestinal tract. The internal organs were otherwise grossly and microscopically unremarkable. Testing of the vitreous fluid detected 24.7 mmol/L potassium, 136 mmol/L sodium, 118 mmol/L chloride, 117 µmol/L creatinine, and 6.9 mmol/L urea. Toxicology results on blood (femoral) were: acetaminophen = 74 mg/L, codeine (free) = 1.30 mg/L, codeine (total) = 1.20 mg/L, clobazam = 0.39 mg, desmethyloclobazam = 5.60 mg/L, valproic acid = 30 mg/L, morphine (free) = 0.03 mg/L, morphine (total) = 0.09 mg/L. Medication (100 Tylenol): acetaminophen = 28 mg/mL, codeine = 1.10 mg/mL. Stomach contents: acetaminophen = 50 mg/L, codeine = 6.20 mg/L.

Conclusion: While some blood levels of medications like clobazam and valproic acid appeared to be unremarkable, the levels of codeine and acetaminophen were significantly elevated. Due to the unexpected and sudden lethal outcome the investigations concentrated on the role of codeine. Altered pharmacokinetics in conjunction with an acute renal failure likely led to the accumulation of codeine after just three doses of Tylenol. Consequently, the cause of death was attributed to acute codeine toxicity and the manner of death was classified as accidental.

Key Words: Post Mortem Toxicology, Pharmacokinetics, Codeine

O101

1,5-Anhydroglucitol and Methylglyoxal – New Postmortem Marker for Glucose Metabolism Disorders?

C. Hess*, F. Musshoff and B. Madea

Institute of Forensic Medicine, Department of Forensic Toxicology, University Hospital Bonn, Germany

Objectives: Post mortem diagnosis of diabetes and a diabetic coma can be difficult because of the lack of characteristic morphological findings. Furthermore, glucose might be an unreliable factor because of its metabolism into lactate by glycolysis after death. Hemoglobin A1C or fructosamine can not predict rapid changes in glycemia. 1,5-Anhydroglucitol (1,5-AG), the 1-deoxy form of glucose, competes with glucose for reabsorption in the kidneys. Therefore, diabetics with a permanent hyperglycemia show significantly lower serum concentrations of 1,5-AG than non-diabetics. Methylglyoxal (MG), an alpha-oxoaldehyde, is mainly derived from intermediates of glycolysis, so diabetics show higher serum concentrations than non-diabetics. Both substances are tightly associated with glucose fluctuations and postprandial glucose and can predict rapid changes in glycemia. Our objective was to develop liquid chromatography tandem mass spectrometric methods for the determination of both compounds and to see if an ante-mortem hyperglycemia can be proved using the analyte concentrations.

Materials and Methods: For 1,5-AG 50 µL of serum or post mortem blood were treated as follows: after a protein precipitation step the supernatant was diluted 1 to 5 with acetonitrile and separated isocratically over a polar NH₂-endcapped column. Sample preparation for MG involves protein precipitation with perchloric acid to release MG from its high plasma protein bond and a derivatization step (24h, 4°C with 2,3-diaminonaphthalen) due to the high reactivity of the dicarbonyl compound. MG and the internal standard are separated over a C18 column. As internal standards, 1,5-Anhydro-D-[¹³C₆] glucitol and 3,4-hexandione were used. Mass spectrometric detection was made in multiple reaction monitoring mode for both analytes with atmospheric pressure chemical ionization in negative mode for 1,5-AG and electrospray in positive mode for MG. The assays were validated according to GTFCh guidelines. Serum of diabetics from a diabetic clinic and non-diabetics was used to assess data about reference concentrations in human serum.

Results and Discussion: Validation of the assays showed linearity from the limits of detection (0,34 µg/mL for 1,5-AG and 1,3 ng/mL for MG) up to 50 µg/mL for 1,5-AG and 500 ng/mL for MG. Imprecision data at three concentrations (3 µg/ml, 15 µg/mL and 40µg/mL for 1,5-AG and 15 ng/mL, 125 ng/ml and 400 ng/mL for MG) were in accordance with the guidelines of the GTFCh (<15%). Reference concentrations for both parameters of hypo- / normo- and hyperglycemic diabetics and non-diabetic volunteers in relation to other parameters of the glucose metabolism (glucose, lactate, HbA1c, human insulin, C-peptide) are presented and discussed. Post-mortem assays were possible: an antemortem unknown diabetes could be detected by determination of 1,5-AG or MG, thresholds are discussed. Concentrations could not distinguish reliably between deaths due to diabetic coma and other causes of death in diabetics.

Key Words: Hyperglycemia, 1,5 Anhydroglucitol, Methylglyoxal, LC-MS/MS

Use and Abuse of Amphetamine in Sweden - Subject Demographics, Concentrations in Blood in the Living and the Dead and the Spectrum of Other Drugs Used**Alan Wayne Jones*** and Anita Holmgren

Department of Forensic Genetics and Forensic Toxicology, National Board of Forensic Medicine, Artillerigatan 12, SE-587 58 Linköping, Sweden

Background: Use and abuse of central stimulants in Sweden started to become a problem in the early 1950s when phenmetrazine (Preludine®) was touted as an appetite suppressant and phenedrine® was considered a pick-me-up or energy booster. The problem became more serious when the intravenous route of administration became popular, because of a more rapid development of tolerance and the need for higher doses of the stimulant. Side-effects included paranoid behaviour and schizophrenic-like symptoms and a rise in drug overdose deaths. Even today, amphetamine tops the list of recreational drugs in Sweden, as verified by toxicological investigations in the living and the dead.

Methods: This retrospective study was done with a forensic toxicology database (TOXBASE), which we searched for cases with positive amphetamine and/or methamphetamine. Over a 10-year period (2001-2010) we located N = 1,183 autopsy cases, N = 20,452 users of illicit drugs and N = 47,366 apprehended drivers (DUID). Both amphetamine and methamphetamine were determined in blood by GC-MS or LC-MS after liquid-liquid extraction and the limit of quantitation for reporting positive results was 0.03 mg/L for both substances.

Results: Amphetamine users in Sweden were predominantly men; autopsy cases (86%), users of illicit drugs (82%) and traffic cases (87%). The men were about 2 y older than the women in each of these forensic categories. The age (mean ± SD) was 39 ± 12 y in autopsy cases, 38 ± 10 y in DUID suspects and 33 ± 10 y in users of illicit drugs. Both the mean age and the proportion of men to women were remarkably constant over the 10-y study period. The mean (median) concentrations of amphetamine in blood was 1.25 (0.40) mg/L in autopsy cases, 0.61 (0.40) mg/L in users of illicit drugs and 0.76 (0.58) mg/L in DUID suspects. The corresponding concentrations of methamphetamine in blood were 0.93 (0.30) mg/L (N = 180) in autopsy cases, 0.38 (0.20) mg/L (N = 2811) in users of illicit drugs and 0.41 (0.22) mg/L (N = 8,496) in DUID suspects. The concentrations of amphetamine were consistently higher in females than males and also in people aged 35-55 y age. In autopsy cases the most commonly encountered co-ingested drugs were benzodiazepines (41%), THC (26%), opiates (21%), alcohol (18%). Poly-drug use was less common in the living; benzodiazepines (13%), THC (12%) and opiates (5%). The median concentration of amphetamine in blood was higher (0.7 mg/L) in mono-intoxication deaths compared with poly-drug deaths (0.4 mg/L).

Discussion: The high median concentration of amphetamine in blood in each of these forensic categories is compelling evidence for abuse of this central stimulant. Considering the widespread use and abuse of amphetamine in Sweden, elevated concentrations were found in only ~100 forensic autopsies annually (mean 5000/year) and amphetamine was given as direct cause of death in only a handful of cases. The median concentration of amphetamine in blood was higher in DUID suspects compared with amphetamine-related deaths. Another interesting finding was that women had a consistently higher median concentration of amphetamine in blood than the men.

Key Words: Abuse, Amphetamine, Autopsy

A Study on the Forensic Toxicokinetics of Popular Poisons in China

Keming Yun*

ShanXi Medical University, Taiyuan, People's Republic of China

Supported by the National Key Technology R & D Program of China (2007BAK26B05)

Objective: Forensic toxicokinetics includes dynamic distribution, postmortem redistribution, toxic decomposition kinetics and postmortem production of forensic poisons. The most frequent poisons found in forensic cases in China are: pesticides; rodenticides; narcotics; sedatives; local anesthetics; and clinical medicines. In this study, animal models were used to assess the forensic toxicokinetics of frequent forensic poisons.

Methods: Rats, rabbits or dogs were administered an antemortem or postmortem dose ($0.5xLD_{50} - 40xLD_{50}$) of common Chinese poisons. Heart, liver, spleen, lung, kidney, brain, stomach, muscle, vitreous humor, heart-blood, peripheral blood, bile and urine were analyzed by GC or GC/MS. Forensic toxicokinetics were evaluated with WinNonlin (Pharsight, Inc.; Mountain View, CA).

Results: 15 poisons exhibited first-order kinetics and one- or two-compartment model toxicokinetics in rats, rabbits or dogs, showing dose dependence for some poisons. 31 poisons exhibited different postmortem distributions, demonstrating mode of administration, dose, or animal dependence. 10 poisons exhibited different dynamic distributions in rats and the toxicokinetics in organ or body fluids were not the same. 19 poisons exhibited a time- and/or site-dependent postmortem variation, or postmortem redistribution in dogs when enough poison was left in the stomach. This could be minimized or prohibited when the corpses were stored at lower temperature. 14 poisons exhibited a time, dose, and/or site-dependent postmortem diffusion in rabbits, which could also be minimized or prohibited when the corpses were stored at lower temperature. The detection of poison in urine, muscle, brain or vitreous humor may be used to identify the administered poison. 25 poisons exhibited a significant decrease in concentration in stored blood and liver of poisoned dogs, which could be minimized when the specimens were stored at lower temperature or 1%NaF or formalin was added. The decomposition kinetics parameters may be used to estimate the toxic concentration in the corpse at the time of death or when the specimens were collected. 10 poisons exhibited different decompositions in sacrificed dogs that were buried, which were time- and dose-dependent. Ethanol and n-propyl alcohol were detected in the dogs stored at room temperature for 12h-72h after the death, and ethanol concentration in the urine was 105 mg/100mL 120h after death.

Conclusions: Forensic toxicokinetics such as dynamic distribution, postmortem redistribution, toxic decomposition kinetics and postmortem production of the most frequent forensic poisons in China were studied. The forensic toxicokinetics parameters will be helpful during forensic identification of poisoning death cases.

Key Words: Forensic Toxicokinetics, China, Poisons

Postmortem Drug Screening by Non-Targeted and Targeted UPLC Mass Spectrometry Technology**Thomas G. Rosano**^{*1}, Michelle Wood², and Thomas A. Swift¹¹Forensic Toxicology Laboratory, Department of Pathology and Laboratory Medicine, Albany Medical Center Hospital and College, Albany NY USA; ²MS Technologies Centre, Waters Corporation, Manchester UK

Objective: In the medical examiner setting, comprehensive drug screening is an essential analytical tool in the investigation of cause and manner of death. The objective of this study is to validate non-targeted and targeted screening assays for drug and metabolite detection in postmortem blood using ultra performance liquid chromatography (UPLC) interfaced with mass spectrometry (MS) in single and tandem stages.

Methods: For non-targeted screening by UPLC/MS electrospray interface, in-source fragmentation with ESI positive and negative modes was used along with MS scanning (80-650 m/z) and library search for over 700 drug and metabolite analytes. Targeted detection of over 200 analytes by UPLC/MS/MS was performed with dual transition ion monitoring.

Results: Validation studies confirmed reproducibility of both the mass spectra produced by in-source fragmentation and the transition ion ratios by collision-cell dissociation. Lower limit of detection by UPLC/MS (10-150 ng/mL) and UPLC/MS/MS (1-50 ng/mL) was determined in blood for a subset of 27 drugs, and analytical sensitivity was correlated with extraction recovery and matrix effect findings. Matrix effect was not significant for the drugs studied, except for early-eluting morphine and oxycodone where ion suppression was detected. Additional recovery and matrix effect studies with representative agents from five drug classes were performed in decomposed postmortem blood and limited matrix effect was determined. Drug findings by UPLC/MS and UPLC/MS/MS were compared with gas chromatography-mass spectrometry (GC/MS) screening in postmortem blood from 410 medical examiner cases with 1121 positive drug findings by all methods. Accuracy based on results of confirmation testing was high (98-99%) across all chromatographic screening assays. Detection sensitivity by GC/MS (71%), UPLC/MS (73%) and UPLC/MS/MS (76%) was determined and combined screening by UPLC/MS and UPLC/MS/MS methods resulted in a drug detection rate of 95%.

Conclusion: UPLC/MS and UPLC/MS/MS assays provide enhanced sensitivity in postmortem drug screening and are in routine use with further customization of UPLC/MS/MS analytes based upon casework findings. In addition, non-targeted UPLC/MS screening allows retrospective identification of casework drugs and metabolites along with continuing development of the mass spectral library.

Key Words: Postmortem Drug Screen, UPLC Mass Spectrometry

O105

Fatal Methanol Poisonings in Finland 2004 – 2010 With Attention to Formic Acid Concentrations**Jenni Viinamäki***, Ilpo Rasanen, Erkki Vuori and Ilkka Ojanperä.

Hjelt Institute, Department of Forensic Medicine, University of Helsinki, Helsinki, Finland

Objectives: Before 1995, general use of methanol products was not allowed in Finland. When the country joined the European Union, methanol-containing car windshield washing fluids became readily available at service stations. This change resulted in a significant increase in fatal methanol poisonings. The objective of this study was to examine the background information and toxicological findings in fatal methanol poisoning cases, with special attention to methanol, ethanol and formic acid concentrations and the postmortem formation of formic acid by putrefaction over the past several years.

Materials and Methods: Blood, urine and/or vitreous humor samples received for postmortem toxicology investigation were analyzed on a routine basis for methanol and ethanol concentrations using dual-column head space gas chromatography with flame ionization detection. Formic acid was measured in blood, urine and/or vitreous humor samples in 37 methanol poisoning cases in which the samples were currently available and in 59 non-methanol putrefied and 117 control cases using head space in-tube extraction (ITEX) gas chromatography – mass spectrometry.

Results: During 2004 – 2010, 158 deaths were classified as methanol poisoning.

Methanol: In fatal methanol poisonings the median (20th percentile; 80th percentile) post-mortem methanol concentration in blood was 2.7 g/L (1.3; 4.0 g/L). Examination of background information revealed that the majority of the fatalities involved middle-aged men (average age 49 years) with a history of alcohol abuse. 75% of deceased (117 cases) were found dead and 25% (41 cases) died in the hospital. The manner of death was classified accidental in 75%, suicidal in 10% and undetermined in 15% of cases by a forensic pathologist.

Ethanol: Ethanol was simultaneously present only in 12 of 158 cases. Of these 12, four were treated with ethanol infusion. In seven hospitalized cases, antemortem breath alcohol analysis indicated significant amounts of ethanol (>1.5%) while no ethanol was detected in postmortem blood or urine samples.

Formic acid: The median (20th percentile; 80th percentile) postmortem formic acid concentration in blood, vitreous humor and urine in methanol poisoning cases were 0.87 g/L (0.64; 0.95 g/L), 0.91 g/L (0.72; 1.1 g/L) and 3.3 g/L (2.3; 4.5 g/L), respectively. There was only a low correlation between the blood formic acid concentration and the blood methanol concentration. No fatal methanol poisoning cases with only formic acid present were found. In putrefied cases, the blood formic acid concentration was higher (0.27 g/L) than in control cases (0.04 g/L). Furthermore, in six putrefied cases, the blood formic acid concentration reached a value normally associated with fatal methanol poisoning (0.5 g/L).

Conclusion: Proper treatment of patients suffering from methanol poisoning may be delayed due to difficulty in diagnosing methanol poisoning. In the fatal methanol poisonings in our study, post-mortem blood methanol concentration varied considerably between individuals, whereas the blood formic acid concentrations usually remained in the concentration range 0.6-1.0 g/L. However, the formic acid concentration in post-mortem blood cannot be used alone as an indicator for methanol poisoning, since formic acid can be produced by putrefaction processes.

Key Words: Methanol Poisoning, Formic Acid, Putrefaction

Distribution of Cannabinoids in Postmortem Specimens

Eric A. Ingle^{*1}, Ann Marie Gordon¹ and Nikolas P. Lemos^{1,2}

¹Office of the Chief Medical Examiner, 850 Bryant Street, San Francisco, CA 94103, USA; ²Department of Laboratory Medicine, School of Medicine, The University of California, San Francisco, CA 94143, USA

Objectives: The goal of this study is to characterize the distribution of three commonly encountered cannabinoids in biological specimens often collected at autopsy.

Methods: An enzyme-linked immunosorbent assay (ELISA) by Venture Labs, Inc. (Redwood City, CA) was used to screen central cardiac blood (BL-C) and urine (UR) specimens for cannabinoids with cutoffs of 5 and 50 ng/mL, respectively. Confirmations and quantitations were by gas chromatography–mass spectrometry in peripheral blood (BL-P) or a new aliquot of UR following overnight unrefrigerated transportation to a contracted reference laboratory with a limit of quantitation of 1 ng/mL for THC and 5 ng/mL for 11-OH-THC and THC-COOH in blood and urine. Internal standards were THC-d₃ and THC-COOH-d₃. For THC-d₃, the target (in bold) and qualifier ions were 389 and 374, and for THC-COOH-d₃ 374, 476 and 491. Target and qualifier ions were 386 and 371 for THC, 371, 473 and 488 for THC-COOH and 371, 459 and 474 for 11-OH-THC. 30 postmortem cases (28 male, 2 female; mean and median age: 38.2 and 35.0 years; age range: 19 - 65 years) were identified with cannabinoids confirmed in blood. For each case the postmortem interval (PMI) was determined from the case history and evaluated in relation to BL-C:BL-P concentration ratios.

Results: Specimen collection at autopsy was on average 1.7 days after death. 12 cases had a time interval of less than 24 h, 8 cases between 24 and 48 h, 3 cases 48 to 72 h and 7 cases had a time interval >72 h. Time intervals ranged between 6 h to 3.5 days. THC was detected in 28 BL-C and all 30 BL-P. THC and THC-COOH were confirmed present in 2 and 23 UR, respectively. 11-OH-THC was detected in 4 BL-C, 6 BL-P and 0 UR. Mean and median THC concentrations in BL-C were 8.0 and 4.2 ng/mL, respectively; mean and median THC concentrations in BL-P were 16.1 and 11.5 ng/mL, respectively. In 30 cases, BL-C: BL-P THC concentration ratios ranged from 0.0 to 2.6 (mean: 0.62; standard deviation: 0.61; median: 0.38). The inactive metabolite THC-COOH was identified in all 30 cases and in all BL-C, BL-P and UR. Mean and median THC-COOH concentrations in BL-C were 57.0 and 37.5 ng/mL, respectively. Mean and median THC-COOH concentrations in BL-P were 61.2 and 32.0 ng/mL, respectively. In the 30 cases where this metabolite was detected, BL-C:BL-P concentration ratios ranged from 0.23 to 3.86 (mean: 1.07; standard deviation: 0.70; median: 0.89). 11-OH-THC was found in 4 BL-C and 6 BL-P specimens. It was not found in UR specimens. Mean and median 11-OH-THC concentrations in BL-C were 14.8 and 10.5 ng/mL, respectively. Mean and median 11-OH-THC concentrations in BL-P were 11.3 and 9.5 ng/mL, respectively. In those 6 cases with THC-OH, the BL-C:BL-P concentration ratios ranged from 0.00 to 1.64 (mean 0.90; standard deviation: 0.74; median:1.17).

Discussion and Conclusions: Our study shows that had toxicology not included cannabinoids, 40% of cases (12/30) based on blood toxicology and 56% of cases (15/27) based on urine toxicology would have mistakenly been deemed as having negative toxicology. Cannabinoids were the only drugs detected in 30% of accidental deaths, 30% of homicides based on blood toxicology and 67% of homicides based on urine toxicology, 71% of natural deaths, 0% in suicides based on blood toxicology and 33% of suicides based on urine toxicology. These results clearly suggest that in order to arrive at a more complete and accurate cause and manner of death, cannabinoids should be included routinely in every type of postmortem toxicology case. Finally, BL-C:BL-P concentration ratios for THC-COOH appear to exhibit a possible trend in relation to PMI.

Key Words: Cannabinoids, Postmortem Redistribution, Autopsy Specimens

**POSTER
PRESENTATIONS**

POSTER 1 – POSTER 300

P001

Analysis of Gamma-hydroxybutyric Acid (GHB) in Urine Samples Using Liquid Chromatography with Tandem Mass Spectrometry (LC-MS/MS)

Jeffery Hackett¹, Albert A. Elian^{2,*}, and Michael J. Telepchak¹

¹UCT Inc., Bristol, PA, USA; ²Massachusetts Police State Crime Laboratory, Sudbury, MA, USA

Objective: In this presentation, attendees will learn about the extraction of gamma-hydroxybutyric acid (GHB) from urine using anion exchange solid phase cartridges and tandem mass spectrometry. Use of this method will permit analysts to provide data on GHB in urine samples using a novel procedure not previously employed by forensic toxicologists.

Method: In this procedure, GHB extraction was performed by solid phase extraction (SPE) employing a strong anion exchange column (QAX). Each SPE cartridge was conditioned with methanol and deionized (DI) water, (3 mL, and 3 mL, respectively) prior to sample loading. Samples of urine for analysis (50 μ L) were diluted with DI water (5 mL) and an internal standard added (GHB-d6). Following the loading of the sample, the SPE sorbent was washed with DI water and methanol (3 mL of each, respectively). After drying the SPE columns, elution was performed with 3 mL of methanol containing 6% by volume of acetic acid (glacial). The individual eluents were collected, evaporated to dryness, and dissolved in mobile phase (100 μ L) for analysis. Liquid-chromatographic analysis was performed in gradient mode on a biphenyl column (150x2.1mm). The mobile phase consisting of B: acetonitrile (containing 0.1% formic acid) and A: aqueous formic acid (0.1%) was started at 25% B for 0.5 minutes rising to 95% B in 1.9 minutes before returning to 25% B for equilibration and re-injection after 2 minutes. The flow rate was 1.25 mL/minute. Tandem mass spectrometry was performed in negative multiple reaction monitoring (MRM) mode (GHB: m/z 103.02 \rightarrow 57.0, 84.9; GHB-d6: m/z 109.13 \rightarrow 90.0, 60.9, (Data presented)).

Results: The method was found to be linear from 500 to 100,000 ng/mL ($r^2 > 0.999$). Recovery of GHB was found to be greater than 80%. Inter-day and intra-day imprecision of GHB were found to be 6% and 9%, respectively. Matrix effects were determined to be <6%. Analysis of 50 authentic urine samples (stored for 1 year (unpreserved)) revealed that 14 samples contained no detectable endogenous GHB, 33 samples contained GHB at endogenous concentrations 500-5110 ng/mL, (mean concentration= 1007 ng/mL), and 3 samples contained GHB at endogenous concentrations below the lowest calibrator (500ng/mL) included in the method.

Conclusion: The use of this new procedure for the analysis of GHB will be of great use to analysts in the field of forensic toxicological analysis as the concentrations of GHB in urine can now be analyzed by a conventional SPE method i.e. condition, load, wash/dry, and elute for further analysis. This procedure permits the ability of automation to be a viable option for high throughput facilities.

Key Words: GHB, LC-MS/MS, SPE

Simultaneous Analysis of Cardiac Glycosides in Blood and Urine by Thermoresponsive LC-MS-MS**Sanae Kanno**^{*1}, Toshiji Mukai¹, Seishiro Hirano² and Osamu Suzuki³¹St. Marianna University School of Medicine, Kawasaki, Japan; ²National Institute for Environmental Studies, Tsukuba, Japan; ³Hamamatsu University School of Medicine, Hamamatsu, Japan

Objectives: Cardiac glycosides (CGs) are widely used for treatment of heart failure. However, CG administration should be made carefully because safe dose ranges are narrow. The simultaneous detection of some CGs using conventional reversed-phase high performance liquid chromatography (HPLC) is difficult because CGs have a wide range of polarity and molecular weight. Recently, a new thermoresponsive column, composed of poly(*N*-isopropyl acrylamide) (PIPAAm) on the surface of silica beads, was developed for HPLC. PIPAAm exhibits thermally reversible hydrophilic/hydrophobic alteration. Thus, adjusting column temperature can easily control separation and elution. In this study, a thermoresponsive polymer column was applied to simultaneous analysis of four CGs in human blood and urine by LC-MS-MS.

Materials and Methods: A method was developed for the following CGs: deslanoside, digoxin, methyl digoxin, digitoxin and digitoxigenin (IS). The analytical column was a PIPAAm hydrogel-modified thermoresponsive column (150 mm X 2.1 mm i.d.). The mobile phase was 2.5 mM ammonium formate buffer (pH 3.4)/methanol (85:15, v/v), with a flow rate of 0.2 mL/min. The capillary temperature was 200°C, collision voltage 15 V, with detection in positive ion mode, SRM detection. The temperature gradient was 50°C with a 1 min hold, to 10°C at 6°C/min. Analytes in blood or urine were extracted by SPE and used for validation data.

Results: As the column temperature changed from 50°C to 10°C over 8 min, five CGs were well resolved by HPLC. With these conditions, we analyzed CGs simultaneously by LC-MS-MS. Validation data as a function of recovery rate, linearity (0.5-25 ng/mL), accuracy and precision (1-5 ng/mL) were generally satisfactory. Detection limits were 0.2-0.3 ng/mL. The method was applied to analysis of methyl digoxin and its main metabolite digoxin in biological matrices obtained from a deceased person in an actual autopsy case.

Conclusion: The thermoresponsive LC-MS-MS method yielded satisfactory results for simultaneous analysis of four CGs. This technique seems to extend the possibility for simultaneous analysis of compounds of different properties, such as hydrophobic precursors and hydrophilic metabolites in biological samples.

Key Words: Poly(*N*-isopropylacrylamide), Cardiac Glycosides, Thermoresponsive

P003

Confirmation of Propoxyphene and Norpropoxyphene in Urine by Laser Diode Thermal Desorption (LDTD)

Patrice Tremblay^{*1}, Pierre Picard¹, William Murphy², Stefany DeOliveira² and Claire Collins²

¹Phytronix Technologies Inc, Québec, P.Que, Canada; ²Calloway Labs, Woburn, MA, USA

Objectives: Propoxyphene is a centrally acting narcotic analgesic agent. Detection and quantification of Propoxyphene and Norpropoxyphene (its metabolite) in urine is traditionally performed by LC/MS/MS or GC/MS analysis. The novel technology of the LDTD system initiates thermal desorption of analytes by use of an infrared laser, generating neutral molecules in the gas phase that have been deposited onto a specially designed 96-well plate. The desorbed sample is transported by a carrier gas (air) through a transfer tube to a corona discharge region to be ionized and then introduced into the mass spectrometer. We propose to validate a confirmation method for Propoxyphene and Norpropoxyphene in urine at a concentration ranging from 12.5 to 12800 ng/mL.

Materials and Methods: A calibration curve, quality control material, and patient specimens are spiked with Internal Standard containing Propoxyphene-D₅ and Norpropoxyphene-D₅. Solid Phase Extraction (SPE) is performed with elution using a basic solution. An automated liquid handling system is used to deliver 2 µL of eluate from the SPE process directly onto the individual wells of a specially constructed 96-well plate (Phytronix LazWell). The LDTD-APCI-MS/MS analysis: Laser Diode Thermal Desorption coupled with triple quadrupole mass spectrometer (API 4000 from ABSciex) was used for instrumentation.

Results: The calibration curves show excellent linearity with $r^2 > 0.99$, and the limits of detection and quantification were established to be 25 and 50 ng/mL for both analytes while the upper limit of linearity was set at 128,000 ng/ml for both compounds. To establish accuracy, 40 patient specimens were sent to a reference laboratory for GC/MS analysis, tested in-house by LDTD, and the results compared. All samples within the reportable range correlated quantitatively within $\pm 20\%$. All negative samples correlated qualitatively. Samples provided for proficiency testing by the College of American Pathologists (CAP) were also analyzed by LDTD to further establish accuracy. Results were all within the acceptable CAP published range. The within-run and between-run imprecision was evaluated (with 40 authentic urine specimens) to be less than 6.3 % for both analytes. The wet stability was evaluated to within 4-days and the Lazwell plate (dry sample) stability to be 3-days. Finally, the carryover limit was set at 50,000 ng/mL and no interferences from common medications were observed. Therefore, this LDTD-MS/MS method is now validated and in use in production in replacement of the LC-MS/MS method, for authentic human urine samples in quantifying propoxyphene and Norpropoxyphene.

Conclusions: LDTD technology provides unique advantages in developing an ultra fast method for analysis of Propoxyphene and Norpropoxyphene in urine. This method has demonstrated, both during validation and in production, accurate, precise and stable results at a speed 37-time faster than the GC-MS method.

Key Words: High Throughput, LDTD-MS/M, Propoxyphene

Confirmation of Methadone and EDDP in Urine by Laser Diode Thermal Desorption (LDTD)-Mass Spectrometry

Patrice Tremblay^{*1}, Gregory Blachon¹, Pierre Picard¹, William Murphy², Stefany DeOliveira² and Claire Collins²
¹Phytronix Technologies Inc, Québec, P.Que, Canada; ²Calloway Labs, Woburn, MA, USA

Introduction and Objectives: The limitations of traditional GC-MS analysis of methadone and its metabolite EDDP in urine include lengthy run-time, risk of carryover, and costs associated with derivatization and column replacement. By installing a LDTD ionization source on a Triple Quadrupole MS system (LDTD-MS/MS) an ultra fast instrumental system was developed that avoids these limitations and provides additional advantages. We propose to validate this method for the confirmation of methadone and EDDP in urine. To demonstrate accuracy, authentic patient samples as well as proficiency test samples from the College of American Pathologists were tested using the LDTD-MS/MS and compared to the results obtained from multiple laboratories utilizing GC/MS analysis.

Materials and Methods: In this method, internal standards (methadone-d9 and EDDP-d3) were added to urine specimens, which were buffered and extracted using solid phase extraction (SPE). Using an automated liquid handling system, eluate from the SPE process was spotted directly into the wells of a specially constructed 96-well plate and dried.

Results: The analysis of both drugs over the calibration range (30-9,600 ng/mL) was found to exhibit excellent linearity with $R^2 > 0.99$. The within-run imprecision (QC at 2,132 ng/mL for methadone and at 2,956 ng/mL for EDDP, n=24) was evaluated to be <5 %, while the between-run evaluated with 24 specimens tested on 3 different runs showed bias of <13.5 % for methadone and <19.1 % for EDDP. No carryover and no interferences from common over-the-counter medications were observed. The wet stability was evaluated within 4 days and the LazWell plate (dry sample) stability to be 3 days. Finally, 40 urine specimens, covering a wide range of concentrations and including negative samples, were run in GC-MS and in LDTD-MS/MS for comparison. All samples were matching within ± 20 %.

Conclusions: The LDTD-MS/MS approach provides fast, accurate and precise results within 8 seconds per sample thereby increasing the throughput as compared to the GC-MS (15 min/run) by a factor of 112-times. Moreover, the reduction in sample analysis time greatly improved sample throughput. Furthermore, the analysis was performed without the need for chemical derivatization thereby reducing costs and exposure to hazardous materials.

Key Words: High Throughput, LDTD-MS/MS, Methadone

Direct and Automated Analysis of Dried Blood Spots Coupled with Liquid Chromatography-Mass Spectrometry**Julien Déglon***^{1,2}, Aurélien Thomas^{1,2}, Estelle Lauer¹, Patrice Mangin¹, and Christian Staub^{1,2}¹Unit of Toxicology, CURML, University Hospitals of Geneva, Switzerland; ²Swiss Center of Applied Human Toxicology, University of Geneva, Switzerland

Objectives: Over the past decade, dried blood spot (DBS) sampling has emerged as a powerful alternative approach for clinical and pharmaceutical analysis compared to conventional venipuncture procedure. The DBS process affords numerous advantages that range from better shipment/storage logistics to a less invasive and more ethical sampling procedure. Due to these advantages, this alternative sampling mode has been successfully introduced for various biomedical applications, including newborn screening, therapeutic drug monitoring (TDM) programs, clinical investigations, and epidemiological or surveillance studies. However, the lack of automated sample preparation requires manual off-line extraction, making this procedure cumbersome in analytical laboratories. To bypass this limitation, we recently developed a home-made automated process allowing for the on-line extraction of multiple DBS samples directly into a conventional LC system with subsequent MS/MS detection. Called “on-line DBS”, this procedure allows for the simultaneous analysis of 30 DBS without any sample pretreatment.

Method: Before analysis, DBS samples (5 µL) were punched out and set into the home-made prototype to be automatically extracted into the analytical system. The developed prototype was based on a rotative plate machined to host multiple wells where filter paper can manually be placed. Next, an automatic clamp that contains two pistons was programmed to sequentially ensure the lock of the well positions. This system setup allowed for thirty DBS samples to be successively analyzed. The selective desorption of the analytes from the filter paper was carried out by the organic mobile phase prior to loading on the RP-LC column. After their separation in a gradient elution mode, the analytes were detected using a tandem mass spectrometer (MS/MS) operating in MRM mode with ESI source [1].

Results: Among the different biomedical approaches tested, the automated on-line DBS concept was fully validated based on international criteria and applied to the pharmacokinetic study of flurbiprofen (FLB) and its metabolite 4-hydroxyflurbiprofen (OH-FLB) and the evaluation of cytochrome P450 2C9 activity in human volunteers [1]. After obtaining excellent results from the FLB pharmacokinetics study, this method was successfully applied to other clinical and toxicological applications including TDM, target screening, and biomarkers identification.

Conclusion: In addition to selective and sensitive MS/MS detection, the on-line DBS procedure gave superior results in the rapid identification and quantification of pharmaceuticals, combining the advantages of a patient-friendly sampling process with a simple and automated analytical method.

References:

1. Automated system for on-line desorption of dried blood spots applied to LC/MS/MS pharmacokinetic study of flurbiprofen and its metabolite. Déglon et al. *J Pharm Biomed Anal.* 2011, 54(2), 359-67.

Key Words: Dried Blood Spots, Direct LC-MS/MS Analysis, Automated On-Line DBS

Rapid Isolation of Tetrahydrocannabinolic Acid A From *Cannabis Sativa* Using Flash Chromatography

Ariane Wohlfarth^{1,*}, Hellmut Mahler² and Volker Auwärter¹

¹Institute of Forensic Medicine, University Medical Center, Freiburg, Germany; ²Northrhine-Westphalia Forensic Institute, the Landeskriminalamt NRW - Crime Investigation Authority, Duesseldorf, Germany

Introduction: (-)- Δ^9 -Tetrahydrocannabinolic acid A (THCA) is the most abundant cannabinoid in cannabis and the non-psychoactive biogenetic precursor of (-)- Δ^9 -tetrahydrocannabinol (THC). THCA rapidly decarboxylates to form THC when heated and under alkaline conditions. For our studies, we required some hundred milligrams of pure THCA. Since previously published methods either use toxic solvents or were rather time-consuming we decided to develop a more simple and rapid isolation procedure. The new procedure should not use harmful solvents and should yield THCA with high purity (> 98 %, THC < 1%) in a milligram range.

Methods and Materials: Pre-extraction: 740 g marijuana were frozen, pulverized and extracted by occasional shaking with 3 L ethanol at 4°C for 96 h. After filtration, the extract was treated with 20 g activated carbon at 4°C for 72 h. The sample was subsequently refiltered prior to being concentrated under vacuum using a rotary evaporator at 30°C.

Flash chromatography: Two flash chromatography systems that could be used independently from each other were developed to separate THCA out of the crude cannabis extract. In both systems UV absorption at 209 and 270 nm were monitored.

System 1: normal phase silica column (120 g) and cyclohexane and acetone as mobile phases - both spiked with the modifier pyridine (0.1%). Gradient elution was performed over 15 minutes. After the chromatographic run the THCA-containing fractions were pooled, extracted with hydrochloric acid to eliminate pyridine and evaporated to dryness.

System 2: reverse phase C18 column (150 g) combined with 0.1% formic acid and methanol as mobile phases. The gradient was run over 20 minutes. After pooling the THCA-containing fractions, methanol was removed in a rotary evaporator. THCA was re-extracted from the remaining aqueous phase with methyl tert-butyl ether. The organic phase was finally evaporated under high vacuum conditions.

Quantitation and proof of purity: Purity was determined by HPLC-DAD analysis. Additionally, the THC concentration was measured. NMR analysis definitely identified the white powder as THCA. GC-MS analysis served for further confirmation.

Results: Loading 1800 mg cannabis extract on the normal phase column (120 g cartridge) yielded 623 mg THCA with a purity of 99.8 % and a THC concentration of 0.09 %. Loading 300 mg cannabis extract on the reversed-phase column (150 g cartridge), which has the advantage of being reusable up to 20 times, yielded 51 mg THCA with a purity of 98.8 % and a THC concentration of 0.67 %.

Key Words: (-)- Δ^9 -Tetrahydrocannabinolic Acid A, Isolation, Flash Chromatography

P007

Analysis of Amphetamines and Cannabis by Head-Space APCI/ITMS

M. Yamada^{*1}, T. Yokokura¹, T. Shishika¹, H. Morokuma¹, M. Hashimoto¹, Y. Hashimoto², H. Inoue³

¹Hitachi High-Technologies Corp., Hitachinaka, Ibaraki, Japan; ²Hitachi Ltd., Central Research Lab., Kokubunji, Tokyo, Japan; ³National Research Institute of Police Science, Kashiwa, Chiba, Japan

Partially supported by “R&D Program for Implementation of Anti-Crime and Anti-Terrorism Technologies for a Safe and Secure Society”, Special Coordination Fund for Promoting Science and Technology of the Ministry of Education, Culture, Sports, Science and Technology of the Japanese Government.

Introduction: For rapid screening of amphetamines and cannabis, direct analysis of sample by head-space atmospheric pressure chemical ionization (APCI) / ion trap mass spectrometry (ITMS) is studied. The system directly and continuously sends the head-space gas in the sample vial to an APCI ion source without using a syringe, unlike the conventional head-space GC/MS methods. Since there is no GC separation, the system can detect the drugs in 5 min. MS/MS analysis is applied to achieve higher selectivity and sensitivity.

Methods: One half (0.5) milliliter of water or urine samples was spiked with the following drugs, Methamphetamine, Amphetamine, MDMA, and MDA, into a 10-ml vial containing K₂CO₃ (0.6g), then tightly sealed. Helium at 10 ml/min was introduced into the vial through a stainless steel tube, and the head-space from the vial was directly introduced to ion-molecule reaction part of the APCI ion source through a heated capillary tube. Drug molecules were protonated at the ion source, and the ions were sent to the mass spectrometer and analyzed under MS/MS mode. For detecting cannabinoids (THC, CBD, and CBN) from cannabis resin and leaf, one half milliliter of water with the sample was poured into the vial, and was analyzed by the same procedure.

Results: Intensities of the product ions from the drugs rapidly increased just after the helium was introduced. The intensities reached the highest levels after 3–5 min, and then decreased. The lower limit of detection (LOD) was estimated from the signal of the highest peak and the noise from water blank sample (S/N=3). LODs of the amphetamines in urine ranged from 0.005-0.1 µg/ml. The signal variation (RSD) due to different sample matrix effect was within 30%. One milligram of cannabis resin and leaf was enough for detection of cannabinoids.

Conclusion: We developed the head-space APCI/ITMS method for rapid screening of amphetamines and cannabis. The time for screening one sample was less than 5 min. The system would be helpful for rapid on-site drug screening of urine samples.

Key Words: Urine, Mass Analysis, Rapid Screening

P008

Synthesis of an Isotopically Labelled Internal Standard for THCA-A by Reaction of Δ^9 -THC-D₃ with Magnesium Methyl Carbonate (MMC)

Nadine Roth*, Ariane Wohlfarth and Volker Auwärter

Institute of Forensic Medicine, University Medical Center Freiburg, Germany

Introduction: Δ^9 -Tetrahydrocannabinolic acid A (THCA-A) is the main cannabinoid component in fresh hemp material and the non psychoactive precursor of Δ^9 -Tetrahydrocannabinol (Δ^9 -THC). While smoking a cannabis cigarette or baking cookies, THCA-A is partially converted into the psychoactive Δ^9 -THC via decarboxylation. Not all THCA-A is decarboxylated and some may be ingested. Hence, THCA-A is a promising candidate for use as a marker for cannabis use.

Objective: For reliable quantification of THCA-A by LC-MS/MS or GC-MS/MS, an isotopically labelled internal standard is required. At present such an internal standard is not commercially available. Therefore we synthesized THCA-A-D₃, starting from Δ^9 -THC-D₃. Our strategy was based on a paper of *Mechoulam et al.* (1969). The authors describe the introduction of a carboxyl-group using MMC. Before using the rather costly Δ^9 -THC-D₃, the procedure was evaluated using purified Δ^9 -THC, which was isolated from fresh plant material. In preliminary experiments synthesis conditions (amount of MMC, hydrolysis temperature) were varied systematically to optimize yield and purity of the product. Using these optimized conditions (10-fold molar excess of MMC and hydrolysis at RT), we synthesized THCA-A-D₃ by reaction of Δ^9 -THC-D₃ with MMC.

Materials and Methods: Δ^9 -THC-D₃ was heated with 10-fold molar excess 2M MMC in DMF at 120°C for 3 h. To avoid oxidation of Δ^9 -THC-D₃ to cannabinol (CBN), synthesis was performed under an inert gas atmosphere (N₂). To prevent hydrolysis of MMC prior to the reaction, the inert gas had to be dried. For pressure compensation a balloon was used. After hydrolysis with diluted hydrochloric acid at ambient temperature and extraction into methyl *tert*-butyl ether, products were identified by GC-MS. Preparative HPLC was employed to separate the synthesis product from unchanged starting material.

Results: Yield of carboxylation was approximately 10% (in reference to amount of Δ^9 -THC-D₃), in accordance with our first experiments with Δ^9 -THC and the data of *Mechoulam et al.* Due to the relatively low yield, a recycling process was adapted. Therefore, separation by preparative HPLC did not only involve purification of the product, it also comprised the recovery of Δ^9 -THC-D₃ for reuse in another synthesis cycle. The EI-MS spectrum of THCA-A-D₃ shows a difference of $m/z = 3$ for all fragments containing the deuterated terminal methyl group of the pentyl side chain. The most abundant fragments after derivatisation with MSTFA were as follows: THCA-A (m/z): 487, THCA-A-D₃ (m/z): 490. Isotope purity was estimated to be > 99% by relative abundance of the molecular ion.

Conclusion: We established a two-step synthesis for THCA-A-D₃. This compound will be used as an internal standard for the reliable quantification of THCA-A by LC-MS/MS or GC-MS/MS in blood, urine and hair samples.

Key words: THCA-A, Δ^9 -THC-D₃, Cannabis Consumption Marker

P009

Identification of Xenobiotics in Human Plasma/Serum Using Automated Sample Preparation, Standardized High-Performance-Liquid Chromatography, High Resolution Mass Spectrometry and Platform-Independent Libraries

Thomas Grobosch*, Christoph Köhler and Torsten Binscheck

Institute of Toxicology, Clinical Toxicology and Poison Information Centre, BBGes, Oranienburger Str. 285, D-13437 Berlin, Germany

Objectives: The aims of this study were to develop a fully automated on-line extraction screening method (XLC-QqTOF) for xenobiotics and to employ platform-independent low and high resolution mass spectral reference libraries to form a comprehensive report.

Materials and Methods: The XLC-QqTOF consisted of a Symbiosis Pico system (Spark Holland, The Netherlands) and a QStar[®] Elite QqTOF mass spectrometer (AB Sciex, Foster City, CA, USA). Five weak ion exchangers (WCXs, pH 6) and four reversed phase (pH 9) sorbents were tested for solid phase extraction. Ten high performance liquid chromatography (HPLC) columns were analyzed, gradient elution and solvent management optimized. QqTOF detection parameters were adjusted for molecular masses ranging from 101 to 950 Da in positive time of flight (TOF) mass spectrometry (MS) and TOF MS/MS mode using information dependent acquisition. The analyzed samples/data files were evaluated by the software SmileMS (GeneBio, Geneva, Switzerland) using low mass resolution spectra libraries (e.g. iMethod[™] Forensic MS/MS, AB Sciex) and high mass resolution spectra (QqTOF, in-house library).

Results: Waters Oasis WCX (pH=6) and a 150 x 2mm, 5 μ m Luna pentafluorophenyl column (Phenomenex) yielded the best chromatography results in terms of peak symmetry and intensity. The mobile phases consisted of 1% formic acid in water (v/v) and methanol at a flow rate of 0.3 mL/min. Time of analysis was 30 min, including sample pre-treatment (5 min) and comprehensive reporting (5 min). Mass accuracies were $\leq \pm 5$ ppm and retention time CVs $< 5\%$ (six month period). More than 100 intoxications (clinical toxicological investigations of plasma/serum samples) were analyzed and parent drugs and metabolites were successfully identified using low (> 1200 entries) and high mass resolution spectra (> 400 entries; indomethacin, paracetamol, metformin, naproxen, sotalol and THC, THC-OH, THC-COOH), when drug concentrations were > 50 μ g/L.

Conclusion: The developed method provides easy sample preparation, robust chromatography, QqTOF detection, platform-independent comprehensive reporting for both multi-targeted and general unknown screening of xenobiotics in human plasma/serum samples.

Key Words: Systematic Toxicological Analysis (STA), On-line SPE, XLC-QqTOF

Proof of Concept for a Rapid and Simple Method for the Analysis of Amphetamines and Psychotropic Drugs in Urine Using High Temperature Vaporization and Diffusion Solid Phase Microextraction Technique**Hiroshi Fujii**^{*1}, Kenji Hara², Masayuki Kashiwagi², Aya Matsusue², Brian Waters² and Shin-ichi Kubo²¹Narcotics Control Department, Kyushu Regional Bureau of Health and Welfare, Ministry of Health, Labour and Welfare, Fukuoka, Japan; ²Department of Forensic Medicine, Faculty of Medicine, Fukuoka University, Fukuoka, Japan

Objectives: The screening of drugs in urine often requires a rapid and sensitive method to quickly and easily determine if drugs are present or not. Examples of sample preparation methods for drug analysis in urine include liquid-liquid extraction (LLE) using organic solvents and headspace-solid phase microextraction (HS-SPME). Usually HS-SPME is done in a closed system, which does not allow heating to temperatures higher than 100°C. This makes it difficult to vaporize the high molecular weight and hydrophilic drugs into the headspace. Opening the closed system by piercing a syringe needle into the vial septum allows for heating to higher temperatures and thus for vaporizing those drugs and making them accessible for HS-SPME and GC-MS analysis. This rapid and simple high temperature vaporization and diffusion SPME technique, without using organic solvents, was applied to the analysis of amphetamines and psychotropic drugs.

Materials and Methods: Drug-free urine was spiked with methanolic solutions of amphetamines and the following psychotropic drugs for a final concentration of 5 µg/mL: methylphenidate, phenobarbital, mazindol, flunitrazepam, nimetazepam, nitrazepam, triazolam and brotizolam. Urease was added to dissolve any urea generated from the heating of the sample, to increase the pH to over 9, and to depolarize the drugs. 0.1mL aliquots were transferred into vials. The SPME fiber was inserted into the vial and the vial heated to temperatures between 210 and 320°C from 1 to 10 min. At the same time, a second needle was inserted into the vial to release the pressure and allow water vapor to evacuate. The lower temperature of the SPME fiber actuated the adsorption of the vaporized drugs onto the fiber. A GC-MS in selected ion monitoring (SIM) mode with short narrow-bore capillary column (DB-5, 10m, diameter 0.1mm, film thickness 0.4µm) was used for analysis.

Results: When HS-SPME method was performed on blank urine spiked with the psychotropic drugs by heating at 270°C for 10min for adsorption to the fiber, the S/N ratios in SIM mode were ≥ 10 . An actual urine sample from a methamphetamine abuser was extracted by LLE and quantified by GC-MS. The methamphetamine and amphetamine concentrations were 1.5 and 0.5µg/mL, respectively. The sample was evaluated with the HS-SPME method to gauge the method's limit of detection with heating at 270°C for 1min for adsorption to the fiber. The S/N ratios of methamphetamine (m/z58) and amphetamine (m/z44) were 2337 and 150, respectively. These results indicate that the HS-SPME method in comparison to LLE appears promising for screening for amphetamines and psychotropic drugs, while avoiding the use of organic solvents for extraction, and reducing extraction and analysis time from over 30 to fewer than 20 min. It is believed that this type of simple and rapid sample preparation method could be beneficial to laboratories that utilize GC-MS as a screening instrument.

Conclusion: High temperature vaporization and diffusion solid-phase microextraction appears promising to screen for amphetamines and psychotropics in urine.

Key Words: Drug Analysis, Solid Phase Microextraction Technique, High Temperature Vaporization

Determination of Cocaine and Cocaine Metabolites in Single Hairs by the MALDI LTQ Orbitrap XL Instrument – Preliminary Results**Frank Musshoff**^{*1}, Kerstin Strupat² and Tabiwang Arrey²¹Institute of Forensic Medicine, University Hospital, Bonn, Germany; ²Thermo Fisher Scientific, Bremen, Germany

Introduction: Conventional hair testing procedures involve several steps: washing, extraction, clean-up and analysis by chromatographic techniques. The analysis of segments with lengths of 1-3 cm produces average concentrations for these time periods, but with poor resolution of time. Matrix-assisted laser desorption/ionization (MALDI) mass spectrometry imaging (MSI) as a complementary technique could be very helpful for drug detection in such complex biomatrices for forensic or clinical purposes.

Materials and Methods: In a preliminary test, 4 single hairs from the same individual were analyzed for the presence of cocaine by use of the MALDI LTQ Orbitrap XL instrument. Hair strands were fixed on a sample plate using double sided adhesive tape and an α -cyano-4-hydroxycinnamic acid (CHCA) matrix was manually spotted onto the hair strains. Fourier transform mass spectrometric full scans were obtained moving from the hair root region towards the hair tip.

Results: After washing, hair number one, cocaine (exact mass 304.15433) was identified mostly from the root of the hair and then towards the hair tip. This was confirmed by analysis of a second single hair. Drug concentrations determined by conventional LC-MS/MS based on a hair strand were as follows: cocaine 3.3 ng/mg and benzoylecgonine 0.7 ng/mg. Using this technique, we found time-related information concerning the behavioural pattern of the consumer with high resolution of time. Based on the analytical findings, cocaine was not administered during the whole period of time, but there were two particular periods where cocaine was used, one of them 3 months prior to sampling and the other one 6 ½ to 9 months before. In addition to cocaine, we were able to detect cocaine metabolites with masses 290.13868 (benzoylecgonine/norcocaine), and 318.16998 (cocaethylene). We obtained negative results in two further single hairs of the same subject analyzed under the same conditions.

Conclusion: These preliminary results confirm the applicability of MALDI-MSI for determination of drugs and pharmaceuticals in hair samples in forensic toxicology. The high chronological resolution allows enhanced interpretation concerning the periods of drug administration. However, the results with 2 negative hairs have also demonstrated that hair analysis of single hairs can lead to misinterpretation. Different growth rates have to be considered, but especially the phenomenon of different stages (anagen, catagen, telogen). An analysis of a single hair cannot be recommended in routine testing. Further investigations on this approach are necessary.

Key Words: Hair, Cocaine, MALDI LTQ Orbitrap, Single Hair

Development of an ELISA for Detection of Tapentadol in Oral Fluid and Blood

Warren C. Rodrigues*, Guohong Wang, Christine Moore, Catherine Castro, Philip Catbagan, and James Soares
Immunoanalysis Corporation, Pomona, CA, USA

Introduction and Objectives: Tapentadol (Nucynta™) is a centrally acting analgesic and a μ -opioid receptor agonist, synthesized as a structural analog to tramadol with abuse potential and addiction similar to hydromorphone. To date there are no enzyme linked immunosorbent assay (ELISA) screening methods reported for tapentadol in oral fluid. Oral fluid is a useful alternative matrix to urine, due to observed collection and adulteration difficulty. This study describes the first tapentadol ELISA method using oral fluid and blood.

Materials and Methods: Oral fluid was collected with the Quantisal™ device, which collects a fixed volume and is diluted with a stabilization buffer in the device. The ELISA method employs competitive binding between enzyme conjugate and free analyte in the sample for a fixed amount of antibody binding sites, proportional to their concentration in the mixture. Tapentadol specific polyclonal antibodies were raised through rabbit immunization with tapentadol antigen. The immunoglobulin G (IgG) fraction was purified from the rabbit serum and coated on microtiter plates. The enzyme conjugate consisted of tapentadol labeled with horseradish peroxidase. The sample volumes used were 10 μ L for oral fluid and 25 μ L for blood. The assay is colorimetric and absorbance was measured at dual wavelengths of 450 and 650 nm using a plate reader.

Results: The limit of detection (LOD) of the assay was 100 pg/mL and the recommended cut-off was 25 ng/mL for oral fluid and blood (1:10 sample dilution). The cutoffs were designed based on the linearity of the dose response curves shown in the figure below to achieve at least two standard deviations between calibrators around the cutoff.

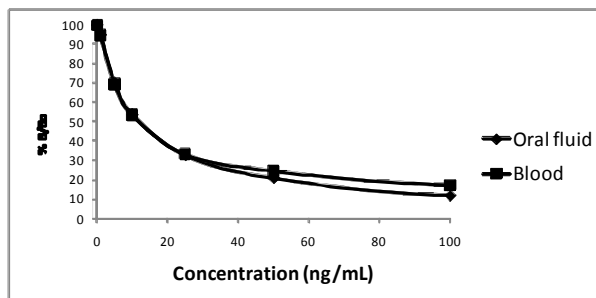

Validation: Intra-day ($n=8$) and inter-day ($n=80$) imprecisions were $<10\%$. No cross-reactivity was detected with *N*-desmethyltapentadol, tramadol, *N*-desmethyltramadol, *O*-desmethyltramadol or compounds from other drug classes when screened at 10,000 ng/mL. The assay was further validated with 34 confirmed negative oral fluid and 22 blood specimens fortified with tapentadol. No false positives or negatives were observed at the 25 ng/mL assay cut-off.

Conclusions: This method is highly sensitive and specific for the detection of tapentadol in oral fluid and blood. Since oral fluid is becoming an important toxicological matrix, this method would be useful to pain management laboratories to monitor tapentadol usage with oral fluid or blood.

Key Words: Tapentadol, Oral Fluid, ELISA

A Novel ELISA Screen for Detection of Sufentanil in Human Body Fluids

Warren C. Rodrigues*, Guohong Wang, Catherine Castro, Philip Catbagan and James Soares
Immunoanalysis Corporation, Pomona, CA, USA

Introduction and Objectives: Sufentanil citrate marketed under the brand name Sufenta™, is a synthetic opioid analgesic drug, which is 5 to 10 times more potent than its analog, fentanyl. It is used for pain management over short periods of time. Sufentanil also has sedative effects, which makes it useful as an intravenous anesthetic. Though mostly administered intravenously, it is also being introduced in the form of patches at 20 and 100 ng. Moderate adult doses for major surgical procedures are about 2-8 µg/kg, then supplemental doses of 10-50 µg are given. The drug has an elimination half-life of 164 minutes in adults. The magnitude and duration of CNS and cardiovascular effects may be enhanced when it is administered to patients receiving barbiturates, tranquilizers, other opioids, general anesthetic or other CNS depressants. Sufentanil is a Schedule II controlled substance, that can produce drug dependence of the morphine type and therefore has the potential for being abused. The goal of this study was to provide toxicologists with a novel ELISA screening method for detection of sufentanil in urine and blood.

Results: The limit of detection (LOD) of the assay is 10 pg/mL in both urine and blood. The urine cut-off of the assay is 5 ng/mL and blood cut-off is 0.5 ng/mL (1:10 dilution of sample).

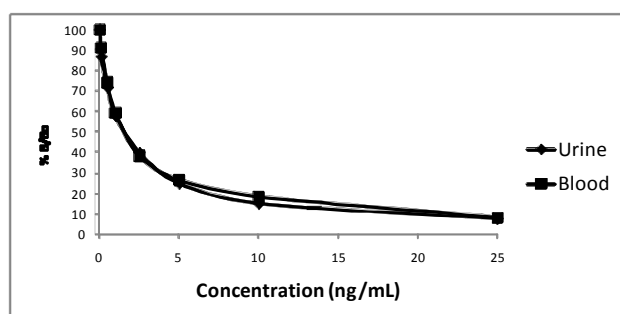

Drug	Conc (ng/mL)	ng/mL of Sufentanil	% CR
Alfentanil	5	1	22
Fentanyl	500	0.5	0.1
Norfentanyl	500	0.5	0.1
Despropionyl Fentanyl	500	0	ND*

D = not detected

Validation: The intra and inter-day imprecisions by ELISA were found to be <10%. The assay is highly specific for sufentanil and shows very low cross-reactivity with its analogous drugs, fentanyl or norfentanyl. There is a 22% cross-reactivity with alfentanil, due to similarities in structure. There was no cross-reactivity observed with other therapeutic drugs and drugs of abuse. The assay was further validated with 25 confirmed negative urine specimens fortified with sufentanil at varying concentrations above and below the cutoff of 5 ng/mL. No false positive or negative results were observed.

Conclusions: The described method is highly sensitive and specific for the detection of sufentanil in urine and blood, with some cross-reactivity with alfentanil as well. This method could be potentially applied to the detection of sufentanil as part of a pain management panel or postmortem toxicological screen.

Key Words: Sufentanil, Pain Management, ELISA

Development of an ELISA for Detection of Diphenhydramine in Urine and Blood

Warren C. Rodrigues*, Guohong Wang, Christine Moore, Catherine Castro, Philip Catbagan, Michael Vincent and James Soares
Immunoanalysis Corporation, Pomona, CA, USA

Introduction and Objectives: Diphenhydramine (DPH) is an over-the-counter first generation antihistamine, commonly marketed under the trade name Benadryl™. Even though it is one of the oldest antihistamines, it is more effective and fast acting than some of the latest prescription drugs, hence its widespread usage. Due to its interactions with an array of other medications, combining DPH with other drugs can have hazardous results. The suggested dosage for adults is in the range of 25-50 mg every 4-6 hours, not to exceed 50-100 mg. The half-life of DPH is about 2-9 hours. Some of the dose (<30%) is excreted as acetyl metabolites and the rest is excreted unchanged as the parent drug. Despite being an effective antihistaminergic agent, DPH has side effects including drowsiness, motor impairment, rapid heartbeat, blurred vision, etc, which makes taking the medication and driving, dangerous. The risk is further increased when DPH is taken concomitantly with alcohol, hence the need to have a screening method for detection of DPH in DUI cases.

Results: The detection limit (LOD) of the assay is 100 pg/mL. The cut-off for urine is 10 ng/mL and blood is 1 ng/mL (1:10 dilution of sample).

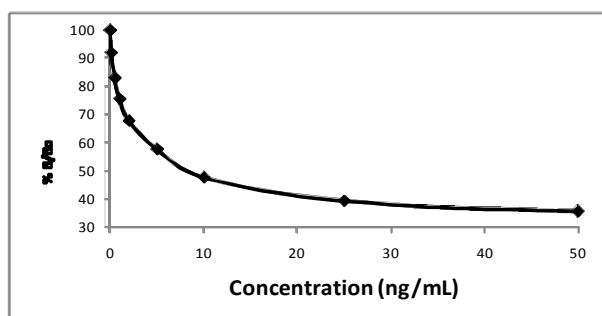

Drug	Conc (ng/mL)	ng/mL of DPH	% Cross-reactivity
Brompheniramine	500	4	1
Chlorpheniramine	500	2	0.5
Doxylamine	1000	5	0.5
Amitriptyline	250	49	19
Clomipramine	100	24	24
Imipramine	250	29	12
Doxepin	250	40	16
Cyclobenzaprine	10	25	250

Validation: The intra and inter-day imprecisions were found to be <10%. The assay is highly specific for diphenhydramine and does not cross-react with other OTC antihistamines. There is an unavoidable cross-reactivity with a few drugs from the tricyclic antidepressant class, due to similarities in structure. However, false positives due to any of these can be eliminated at the confirmation stage. The assay was further validated with blood samples obtained from the LA County Coroner's office and confirmed by GC-MS. There was only one false positive obtained, due to cyclobenzaprine, which has a high cross-reactivity of 250% with the assay.

ELISA	GC-MS	
	+	-
+	20	1
-	0	4

Sensitivity: $20/20 \times 100 = 100\%$
 Specificity: $4/5 \times 100 = 80\%$
 Accuracy: $24/25 \times 100 = 96\%$

Conclusion: The described method is sensitive, specific and precise for the detection of diphenhydramine in urine and blood. This method can be applied to the detection of DPH in the toxicology field as part of a DUI panel.

Key Words: Diphenhydramine, Antihistamine, ELISA

High Sensitive Detection and Analysis of Abused Codacet® (Acetaminophen-Codeine) by Surface-Ionization Methods

Mareta Mukharbekovna Ibragimova¹, Saida Sunnatovna Iskhakova², **Usman Khasanov**^{*2}, Makhmud Mukhametjanovich Shakhitov¹, and Dilshadbek Tursunbaevich Usmanov²

¹Forensic-Medicinal Expertise Bureau, Tashkent, Uzbekistan; ²Arifov Institute of Electronics, 100125 Tashkent, Uzbekistan

Objectives: Unique selectivity and high efficiency of Surface Ionization (SI) of nitrogen bases attracts great attention to this new way of ionization to develop highly selective and sensitive methods and devices based on SI for express analysis of physiologically active organic compounds [1]. The results of detection and analysis of codacet in users' blood and urine by Surface-Ionization Mass Spectrometry (SI/MS) and Atmosphere-Pressure ThermoDesorption Surface-Ionization Spectroscopy (APTDSIS) will be presented.

Materials and Methods: The SI-MS experiments were performed with a modified static magnetic sector mass spectrometer (MX-1320). Oxidized textured tungsten wire with diameter of 200 µm was used as a thermoemitter. The thermoemitter temperature was regulated within a range of 600-1200 K. Sample exposure to the emitter was formed by substance evaporation from a Knudsen cell at 50-120°C. For the APTDSI experiments, an "Iskovich" device was used [1]. The emitter temperature was 700 K, and the air flow was 50 L/h. The evaporator temperature was increased linearly at a rate of 10°C/s from room temperature to 500°C. The TLC studies were conducted on a chromatographic plate TOXLAB and the GC/MS studies by HP-6890. For EI/MS, electron energy was 70 eV, the emission carrier 0.8mA. The chromatographically pure codeine (UNDP/UNIDO), acetaminophen (GlaxoSmithKline, purity 99,9%) and commercial Codacet® (Dr. Abidy I.R. Pakistan) were used. The blood and urine samples of Codacet users underwent a butanol- chloroform extraction [2]. The high selectivity of the SI method allows analysis of the extracts without preliminary chromatographic separation.

Results: The SI/MS studies showed that the SI mass spectra of codeine and acetaminophen significantly differ from those of electron impact. In the SI mass spectrum, dissociative ions of m/z 144, 146 and m/z 108 for codeine and acetaminophen, respectively. The mass spectrum of Codacet consists of a superposition of the mass spectra of its components. The APTDSIS spectra have characteristic maximums corresponding to sublimation temperature of codeine and acetaminophen molecules from the evaporator surface $T_{\max} = 130^{\circ}\text{C}$ and $T_{\max} = 190^{\circ}\text{C}$, respectively, while in the APTDSIS spectra of Codacet both of these maximums are observed. The ionization efficiency of codeine and acetaminophen is 80 C/mol and 6 C/mol, respectively, with the linear range of the concentration dependence 2.0 – 3.0 orders of a magnitude, which allows not only their identification in bio-samples according to characteristic temperature of sublimation, but also determination of their amounts at the 0.1 pmol level. We also have comparative results between traditional TLC and GC/MS with electron ionization.

References:

[1] U. Kh. Rasulev, U. Khasanov, V. V. Palitsin, J. Chromatography A 2000, 896, 3.

[2] U. Kh. Rasulev, U. Khasanov, T.K. Islamov, M.M. Shakhitov, D.T.UsmanovV, Problems of Forensic Sciences, vol.XLIII, 2000, 237-242.

Key Words: Surface Ionization Mass Spectrometry, Atmosphere-Pressure Thermo Desorption Surface-Ionization Spectroscopy, Codacet

Feasibility of Surface-Ionization Methods for Detecting Trace Amounts of Antidiabetic Preparations

Mareta Mukharbekovna Ibragimova¹, Saida Sunnatovna Iskhakova², Latif Tulyaganovich Ikramov¹, **Usman Khasanov**^{*2}, Ukur Khasanovich Rasulev², Makhmudjan Mukhmetjanovich Shakhitov¹ and Dilshod Tursunbaevich Usmanov²
¹Forensic-Medicinal Expertise Bureau, Tashkent, Uzbekistan; ²Arifov Institute of Electronics, 100125 Tashkent, Uzbekistan

Objectives: Surface ionization spectroscopy provides unique selectivity and high efficiency for drug analysis and may be suitable for identification and quantitative forensic drug analysis. Antidiabetics poisoning is encountered during forensic casework. Surface-ionization mass spectrometry (SI/MS) and atmospheric-pressure thermodesorption surface-ionization spectroscopy (APTDSIS) were investigated for analyzing antidiabetic formulations that were oral sulfonylurea, biguanide and thiazolidinedione derivatives.

Materials and Methods: Drug standards and post-mortem blood and urine specimens were extracted by liquid-liquid extraction. Antidiabetic SI/MS and APTDSIS characteristics are detailed in the table below. Due to high polarity and thermal instability of sulfonylurea derivatives we observed that fragmentary ions predominated while quasi-molecular ions $[M-H]^+$ were less abundant for SI/MS analysis. The biguanide and thiazolidinedione molecules are relatively thermally stable and therefore the $[M-H]^+$ ions were observed in the SI/MS mass spectra with 100% and 30% intensity, respectively.

Substances	SI/MS		APTDSIS		
	MW a.m.u.	Base ions (m/z)	Detection limit (pmol)	Ionization efficiency (C/mol)	Linear range
Glibenclamide	494	98	~5.2	~ 21.7	~2.3
Gliclazide	323	110	~1.7	~ 56.8	~2.7
Glipizide	445	98	~5.6	~ 19.6	~2.2
Glimepiride	490	112	~2.8	~34.3	~2.5
Gliquidone	527	98	~2.5	~26.4	~2.4
Metformin	129	128	~6.3	~38.7	~2.7
Rosiglitazone	356	121	~0.3	~263.0	~3.5

Results and Discussion: The APTDSIS spectra of preparations and bio-sample extracts were measured with “Iskovich-1”; Iskovich-1 operating principles are described in [1]. The thermodesorption profiles were characteristic of compounds with low volatility; temperature maximums (T_{max}) were 220–320°C. The ionization efficiency was from 19 C/mol to 263 C/mol with the linear range of the concentration dependence 2.0–3.0 orders of a magnitude. Identification and quantification of antidiabetics in bio-specimens via SI/MS and APTDSIS were demonstrated. Limits of detection via SI/MS and APTDSIS were 100 times lower than TLC and equivalent to HPLC for post-mortem blood and urine analysis.

References:

1. Rasulev U.Kh., Khasanov U., Palitsin V.V. *J. Chromatogr. A.* 2000, 896, 3.

Key Words: Surface Ionization Mass Spectrometry, Atmosphere-Pressure ThermoDesorption Surface-Ionization Spectroscopy, Antidiabetics

Development and Validation of an LC-MS/MS Method for the Detection and Quantification of Designer Drugs, Amfetamines, Cocaine, Opiates and Opioids in Blood and Serum

Nadine Jochum, Markus Hopf and **Andreas Ewald***

Institute of Legal Medicine, Saarland University, Building 42, D-66421 Homburg (Saar), Germany

Objectives: The most frequently requested drugs in our laboratory have been analyzed by GC-MS using two different methods. Our aim was to develop an alternative fast LC-MS/MS method for the simultaneous quantification of designer drugs, cocaine, opiates and opioids in blood and serum.

Materials and Methods: Blood/serum samples were spiked with an internal standard solution containing amfetamine D₅, metamfetamine D₈, benzylpiperazine D₇, MDA D₅, MDMA D₅, MDEA D₅, MBDB D₅, methylecgonine D₃, benzoylecgonine D₃, cocaine D₃, cocaethylene D₃, morphine D₃, codeine D₃, dihydrocodeine D₆ and methadone D₃. Proteins were precipitated with acetonitrile. After centrifugation the supernatant was injected into the Thermo Fisher (TF) TSQ Quantum Ultra LC-MS/MS system. Extraction was achieved using an ion exchange/reversed phase turbulent flow column (TF Cyclone MAX, 0.5 x 50 mm) and separation was performed via a reversed phase column (TF Hypersil Gold, 50 x 2.1 mm, particle size 5µ) using gradient elution with 0.1 % formic acid in water and in acetonitrile, respectively. Identification was based on multiple reaction monitoring (ESI⁺). The runtime was 10 min. Validation was carried out according to the guidelines of the Society of Toxicological and Forensic Chemistry (GTFCh).

Results: The Table below shows some of the validation results. The CVs for intra-assay and inter-assay imprecision ranged from 3.02 % to 21.59 % and from 3.01 % to 10.38 %, respectively. The recovery was greater than 82 % for all analytes and no significant carry over or matrix effects were observed.

Analyte	Limit of detection [ng/mL]	Linearity range [ng/mL]	Transitions	
Amphetamine	3.0	15-500	136/91	136/119
Methamphetamine	2.4	15-500	150/91	150/119
MDA	6.7	15-500	180/133	180/163
MDMA	1.0	15-500	194/105	194/163
MDEA	1.8	15-500	208/133	208/163
MBDB	2.1	15-500	208/147	208/177
BDB	5.8	15-500	194/147	194/177
Benzylpiperazine	1.5	15-500	177/65	177/91
mCPP	2.2	15-500	197/118	197/154
TFMPP	3.0	15-500	231/118	231/188
Cocaine	0.55	1.5-50	304/82	304/182
Benzoylecgonine	10.0	30-1000	290/105	290/168
Methylecgonine	6.6	15-500	200/82	200/182
Cocaethylene	0.23	1.5-50	318/82	318/196
Morphine	1.3	7.5-250	286/165	286/201
Codeine	2.7	7.5-250	300/165	300/215
Dihydrocodeine	2.2	7.5-250	302/199	302/201
Methadone	2.4	15-500	310/223	310/265

Conclusions: This method successfully replaced the two GC-MS methods in our laboratory. The turbulent flow chromatography proved to be simple, fast and time efficient, so it is a good alternative to GC-MS methods.

Key Words: Turbulent Flow Chromatography, LC-MS/MS, ESI

Development and Validation of a Novel Homogeneous Immunoassay for the Detection of Tapentadol in Urine

Guohong Wang*, Kim Huynh, Warren Rodrigues, Rehka Barhate, Christine Moore, Michael Vincent, and James Soares
Immunoanalysis Corporation, Pomona, CA, USA

Introduction and Objectives: The objective of this project was to validate a new high throughput homogeneous enzyme immunoassay (HEIA) for the rapid detection of tapentadol in human urine. Tapentadol is a new and potent opioid analgesic that was approved by the FDA in 2008 for relief of moderate to severe acute pain in patients 18 years and older. Tapentadol is 18 times less potent than morphine and the exact mechanism is unknown. However, its analgesic efficacy is believed to be two mechanisms of action, one as a μ -opioid agonist and the other as the inhibition of norepinephrine reuptake. Since the drug is fairly new to the commercial market, to our knowledge there is no commercially available immunoassay screening method for this drug. For this reason, it is valuable to develop and validate a tapentadol HEIA to detect tapentadol in urine.

Methods: A homogeneous immunoassay was developed and validated for the detection of tapentadol in urine at a screening cutoff of 200ng/mL. Performance validation included cross reactivity of structurally related and unrelated compounds, intra-day and inter-day precision, stability, drug recovery, and parallel studies with authentic tapentadol confirmed positive and negative urine specimens.

Results: The reportable range was 25 to 1000ng/mL for tapentadol. The HEIA cross reacts 25% with its primary metabolite, Tapentadol-O-glucuronide and 2% with its secondary metabolite, N-desmethyl-tapentadol. The intra-day and inter-day coefficients of variation (% CV) for the qualitative and semi-quantitative assay were both less than 1% and 15%, respectively. The HEIA was validated with a total of 191 urine samples previously analyzed by LC/MS-MS with tapentadol concentrations range from 50 to 500,000ng/mL. The sensitivity, specificity and accuracy of the assay were found to be 97%, 98% and 98%, respectively, when the immunoassay cutoff concentration for tapentadol was set at 200ng/mL.

		LC-MS/MS (50 ng/mL)	
		P	N
HEIA (200 ng/mL)	N	• 2	• 115
	P	• 72	• 2

Conclusion: A high throughput HEIA has been developed for the detection of tapentadol in human urine which correlates well with LC-MS/MS. This is the first report of a homogeneous immunoassay for tapentadol.

Key Words: Tapentadol, Urine, Homogeneous Immunoassay

Mix-mode TiO-C₁₈ Monolith Spin Column Extraction and GC-MS Analysis for the Simultaneous Assay of Organophosphorus Compounds, Glufosinate and Glyphosate in Human Serum and Urine

Takeshi Saito^{*,1}, Akira Namera², Hiroshi Oikawa³, Shota Miyazaki³, Akihiro Nakamoto⁴ and Sadaki Inokuchi¹

¹Department of Emergency and Critical Care Medicine, Tokai University School of Medicine; ²Department of Forensic Medicine, Graduate School of Biomedical Sciences, Hiroshima University; ³GL Sciences Inc.; ⁴Scientific Investigation Laboratory, Hiroshima Prefectural Police Headquarters, Japan

Objectives: The simultaneous extraction of lipophilic organophosphates, glufosinate (GLUF) and glyphosate (GLYP) is particularly challenging. However, water-soluble organic phosphates are strongly adsorbed on a TiO₂ column. Therefore, we have prepared a mix-mode TiO-C₁₈ monolith spin column, and in this paper, we utilize it in a method for the extraction of organophosphates, GLUF and GLYP.

Methods: The organophosphates fenitrothion (MEP), malathion and phenthoate (PAP) were selected for this study. All of the targeted compounds, together with the internal standards (MEP-d₆ and DL-2-Amino-3-phosphonopropionic acid), were extracted from both serum and urine utilizing the mix-mode TiO-C₁₈ column.

Results: Recovery of organophosphates from serum and urine spiked at concentrations 0.1, 1, 7.5, and 25 µg/mL, ranged from 12.7% to 49.5%. The recovery of GLUF and GLYP from serum and urine spiked at concentrations 0.5, 3, 30, and 90 µg/mL, ranged from 1.9% to 7.9%. The intra and inter-day accuracy and imprecision (expressed as relative standard deviation, %RSD) evaluated at four quality control levels were within 96.7-107.7% and 4.0 - 13.8% respectively. Detection and quantitation limits for organophosphates in serum and urine were 0.1 and 0.1 µg/mL, and 0.1 and 0.5 µg/mL for GLUF and GLYP, respectively. The validated method was successfully applied to a clinical GLUF poisoning case.

Conclusion: Both the extraction and derivatization times of the presented method and previous methods were compared. In this new method, the sample preparation process prior to injection into the GC-MS, takes approximately 15 min. This presents a one-third reduction of the extraction time as compared to previous methods.

Key Words: Organophosphates, Glyphosate, TiO-C₁₈ Monolithic Spin Column

A Validated Method for Simultaneous Screening and Quantification of 31 Drugs of Abuse in Whole Blood by Fully Automated SPE and UPLC-QTOF/MS

Petur Weihe Dalsgaard^{1,*}, Andrej Jaroslav Rode¹, Brian Schou Rasmussen¹, Marie Kjærgaard Bjørk¹, Diana Ina Petersen², Kathrine Åsberg Madsen², Bente Gammelgaard², and Kirsten Wiese Simonsen¹

¹Section of Forensic Chemistry, Department of Forensic Medicine, Faculty of Health Sciences, University of Copenhagen, Copenhagen, Denmark; ²Department of Pharmaceutics and Analytical Chemistry, Faculty of Pharmaceutical Sciences, University of Copenhagen, Copenhagen, Denmark

Objective: An ultra performance liquid chromatography quadrupole time of flight mass spectrometry (UPLC-QTOF/MS) method for detection of 31 common drugs of abuse in whole blood was developed and validated. The method is used for screening and quantification of common drugs of abuse in whole blood received from autopsy cases and living persons. The detected compounds were: alprazolam, amphetamine, benzoylecgonine, bromazepam, cathine, cathinone, chlordiazepoxide, cocaine, codeine, clonazepam, 7-aminoclonazepam, diazepam, nordiazepam, flunitrazepam, 7-aminoflunitrazepam, ketamine, ketobemidone, 3,4-Methylenedioxyamphetamine (MDA), 3,4-Methylenedioxymeth-amphetamine (MDMA), methamphetamine, methadone, morphine, 6-monoacetylmorphine, nitrazepam, 7-aminonitrazepam, oxazepam, temazepam, tramadol, O-desmethyltramadol, zolpidem and zopiclone.

Method: Blood samples (0.200 g) were extracted with an in-house developed fully automated SPE system (Tecan Freedom EVO 200 equipped with a SPE station using 96-well Phenomenex Strata X-C mixed mode cartridges). Target drugs were quantified using a Waters ACQUITY UPLC[®] system (Waters Acquity HSS C18, 1.8 μm , 2.1 mm x 150 mm column with a 15 min gradient using 5 mM ammonium formate, adjusted to give pH 3 using formic acid and acetonitrile containing 0.1% (v/v) formic acid) coupled to a Waters SYNAPT[®] G2 (ESI⁺, Resolution mode, and MS^E (low energy 4 V, high energy 10-40 V ramping) data acquisition). The use of deuterated internal standards for most compounds verified that the accuracy of the method was not influenced by matrix effects.

Results: Extraction recoveries were 24%–75% for all analytes. Lower limits of quantification were from 5 to 10 $\mu\text{g}/\text{kg}$.

Conclusions: We present a fully validated UPLC-QTOF/MS method for 31 common drugs of abuse in whole blood with a run time of 15 min and using only 0.200 g of whole blood.

Key Words: Drugs of Abuse, UPLC-QTOF/MS, Automated SPE

Simultaneous Determination of Dimethyltryptamine and β -Carbolines in Plasma Samples by LC-MS/MS

Carolina Dizioli Rodrigues Oliveira^{*1}, Guilherme Gonçalves Okai¹, José Luiz da Costa², Rafael Menck de Almeida¹ and Mauricio Yonamine¹

¹Faculty of Pharmaceutical Sciences, University of São Paulo, São Paulo, SP, Brazil; ²Forensic Toxicology and Chemistry Laboratory, Criminalistic Institute of Sao Paulo, SP, Brazil

Introduction: Ayahuasca is a psychoactive plant beverage initially used by shamans in religious rituals practiced by indigenous peoples in the Amazon region. It is prepared by infusing the pounded stems of *Banisteriopsis caapi*, which contains β -carbolines, alkaloids that are potent monoamine oxidase (MAO) inhibitors, together with the leaves of *Psychotria viridis*, which contains the psychedelic agent *N,N*-dimethyltryptamine (DMT). The enzyme MAO normally degrades DMT in the liver and gut. However, the inhibition of MAO by β -carbolines allows the oral activity of DMT, enabling it to reach its site of action in the central nervous system. The synergistic interaction of these alkaloids is the basis of the psychotropic action of ayahuasca. In Brazil, the use of ayahuasca within religious ceremonies is protected by law and it has been incorporated into rituals of syncretic religious groups. Some of these groups established themselves in the United States and European countries, attracting international research interest in the effects of ayahuasca.

Objective: The aim of this study was the development of a method for simultaneous determination of DMT and β -carbolines: harmine (HRM), harmaline (HRL) and tetrahydroharmine (THH) in human plasma by liquid chromatography-tandem mass spectrometry (LC-MS/MS).

Method: A sample solution containing plasma (1.0 mL), borate buffer (pH 9.0, 3.0 mL) and the internal standard DMT-d₆ (100 μ L of a solution at 1.0 μ g/mL) was loaded onto a C18 cartridge. The cartridge was washed with deionised water and further with a solution of acetonitrile/water (1:9). After drying the cartridges under full vacuum for 7 min, the elution of analytes was performed with methanol. The LC mobile phase consisted of a mixture of methanol with 0.1 % formic acid and aqueous solution of 0.1 % formic acid and 5 mmol/L ammonium formate. The LC system was coupled to a 3200QTRAP mass spectrometer using electrospray ionization (ESI-Turbo V) in positive ion mode and multiple reaction monitoring (MRM). Matrix effect was evaluated by comparison of responses given by the injection of extracts added with analytes and direct injection of standards. For specificity tests, blank samples from different non users of ayahuasca were tested.

Results: The LOQs obtained for all analytes were below 0.5 ng/mL. By using the weighted least squares linear regression (weighting factor $1/x^2$), the accuracy of the analytical method was improved at the lower end of the calibration curve (from 0.5 to 100 ng/mL; $r^2 > 0.98$). The inaccuracy and imprecision (concentrations: 1.5, 30, 75 ng/mL) of the assay fall within the generally accepted criteria for bio-analytical assays (<15%). No interference endogenous compound was found. Also, no significant matrix effect was found after the use of solid phase extraction. The method was applied to a plasma sample of a volunteer collected after 3 h of ingestion of 200 mL of ayahuasca. The concentrations found were: DMT 13.7 ng/mL, HRM 5.5 ng/mL, HRL 4.2 ng/mL and THH 63.7 ng/mL.

Conclusion: The developed method can be useful to estimate doses administered to animals and humans for further pharmacological and toxicological investigations of ayahuasca exposure.

Key Words: *N,N*-Dimethyltryptamine, Plasma, LC-MS/MS

Production of Identical Retention Time and Mass Spectrum for Δ^9 -Tetrahydrocannabinol and Cannabidiol Following Derivatisation with Trifluoroacetic Anhydride

Rebecca Andrews and Sue Paterson*

Toxicology Unit, Imperial College London, St. Dunstan's Road, London W6 8RP, England, UK

Objectives: During method development for the analysis of cannabinoids from a single 30-mg hair sample using two-dimensional gas chromatography-mass spectrometry (2D GC-MS) with negative chemical ionization (NCI), it was observed that the use of the derivatizing reagent trifluoroacetic anhydride (TFAA) produced identical retention time and mass spectrum for the trifluoroacyl derivatives of Δ^9 -tetrahydrocannabinol (Δ^9 -THC) and cannabidiol (CBD). This derivatizing reagent coupled with 1,1,1,3,3,3-hexafluoroisopropanol (HFIP) is required to achieve the necessary sensitivity for analysis of 11-nor- Δ^9 -tetrahydrocannabinol-9-carboxylic acid (THC-COOH) in hair using GC-MS with NCI. The purpose of this work was to highlight the unsuitability of the use of TFAA for detection by GC-MS of Δ^9 -THC and CBD, by conducting a simple experiment to compare the characteristics of trimethylsilyl (TMS) and trifluoroacyl derivatives of THC and CBD.

Methods: Initial observations were made using 2D GC-MS with NCI. However, the work presented here was carried out on a standard GC-MS setup with electron impact ionization (EI) as it was the most effective way to illustrate the observations. In brief, aliquots of methanolic standards of Δ^9 -THC and CBD were derivatized separately with *N*-methyl-*N*-(trimethylsilyl)trifluoroacetamide (MSTFA) and TFAA-HFIP. The standards were heated at 70°C for 30 minutes. For the trifluoroacyl derivatives, it was necessary to remove the excess TFAA-HFIP and reconstitute in toluene prior to analysis.

Results: The trifluoroacyl derivatives of Δ^9 -THC and CBD displayed the same retention time and mass spectrum (m/z 327.0, 410.1, 367.1, 342.0, 395.1). Conversion of Δ^9 -THC to CBD occurs by means of a Lewis-acid-catalyzed process due to the acidic properties of TFAA. This was not observed with the TMS derivatives.

Conclusions: The common approach to the derivatization of Δ^9 -THC in biological samples is to analyze for the TMS derivatives. However, the original purpose of this work was to develop a method for the simultaneous analysis of the major cannabinoids from a single 30-mg hair sample. In order to achieve the required sensitivity for THC-COOH, it was necessary to use GC-MS with NCI detection and the derivatizing reagent TFAA-HFIP. The work here highlights that the use of this derivatization is not recommended when detection of Δ^9 -THC and/or CBD is of interest due to the production of identical retention time and mass spectrum for both compounds. This results from the conversion of CBD to Δ^9 -THC in the presence of a Lewis acid.

Key Words: Δ^9 -Tetrahydrocannabinol, Cannabidiol, Trifluoroacetic Anhydride

P023

WITHDRAWN

Validated LC/MS Methods for the Determination of *Amanita Phalloides* Toxins in Human Urine**Barbora Merová**^{*1}, Marie Staňková² and Peter Ondra¹¹Institute of Forensic Medicine and Medical Law, Medical Faculty, Palacký University, Olomouc, Czech Republic; ²Institute of Forensic Medicine, University Hospital, Ostrava, Czech Republic

Supported by the Ministry of Health of the Czech Republic (IGA NS10269-3)

Objectives: *Amanita phalloides*, commonly known as the death cap, is one of the most poisonous toadstools and it is widely distributed across Europe. *Amanita phalloides*, as well as several other members of the genus *Amanita* and some *Conocybe*, *Galerina* and *Lepiota* mushroom species, contain deadly toxic amatoxins (bicyclic octapeptides), which were first isolated in 1941 by H. Wieland. From those, the most toxic are α -amanitin and β -amanitin, which inhibit the RNA polymerase II. The second main group in *A. phalloides* represents phallotoxins (bicyclic heptapeptides), of which phalloidin is the most important. Phallotoxins are not resorbed from a digestive tract, so they are not important for oral poisoning. Nevertheless, intravenous administration of phalloidin has the same effect as amatoxins. We describe rapid and sensitive LC/MS methods for the identification or determination of α -amanitin and β -amanitin in biological materials.

Methods: Solid phase extraction was used for isolation of the toxins from urine. Strata X-CW columns (30 mg, 1 mL) were conditioned with 1 mL of methanol and 1 mL of 0.1 mol/L hydrochloric acid. A 1.0 mL aliquot of urine was loaded onto the SPE column. The column was rinsed with 1 mL of acetate buffer (pH 4.5). The toxins were eluted from the column by 1 mL 5% formic acid in methanol. The eluent was evaporated using nitrogen at 40 °C. The dry residue was dissolved in 0.1 mL of mixture methanol:water and 5 μ L were injected. The experiments were carried out using an LC/MS 2010A quadrupole system (Shimadzu, Japan) and an LC/MS ion trap system (LC Dionex, USA and MS Thermo Scientific, USA) equipped with ESI ion source in positive ion mode. Chromatographic separation was performed on a Synergi RP Polar column (100 x 2 mm, 2.5 mm) in gradient elution with acetate buffer (pH 3.2) and acetonitrile.

Results: Recovery was over 90 % for α -amanitin and β -amanitin. Linearity ranged from 0.002 to 10 μ g/mL for both substances. The LOD (S/N 3) was 0.0006 μ g/mL and LOQ (S/N 10) was 0.002 μ g/mL for both compounds using quadrupole system. LOQ (S/N 10) was 0.01 μ g/mL for both compounds using the ion trap system. The intra-assay imprecision varied from 1.96 to 7.87 % and in the inter-assay imprecision from 1.2 to 9.4 % for α -amanitin. The intra-assay imprecision for β -amanitin varied from 0.42 to 8.26 % and in the inter-assay imprecision from 0.47 to 9.8 %. The inaccuracy ranged from -0.68 % to -8.95 % for α -amanitin and -2.7 % to -8.9 % for β -amanitin. The application of these methods has been demonstrated through the analysis of biological materials from intoxicated patients.

Conclusion: It is very important to quickly distinguish the intoxication caused by *Amanita phalloides* in clinical and forensic toxicology. The LC/MS methods for α -amanitin and β -amanitin determination in human urine using either a quadrupole or an ion trap were developed. The isolation procedure for α - and β -amanitin is suitable for phalloidin as well as for muscarine (*A. muscaria* and *A. pantherina* toxin). These methods are applicable to identification or determination of the toxins in blood, gastric or intestinal content, feces as well as in organs.

Key Words: Amatoxins, Phallotoxins, LC/MS

P025

Detection and Analysis of 30 Compounds in Oral Fluid via Ultra High Pressure LC-MS-MS without Solid Phase Extraction

Emilee L. Borgmeier, Jessica M. Marsh, Heather L. Workman, **Erica A. Guice***
Western Slope Laboratory, Troy, MI, USA

Objectives: In the fields of pain management and addiction control, there is a need for an efficient and reliable oral fluid testing method for a multitude of commonly prescribed and illicit drugs. Oral fluid testing has become more desirable in the last decade because it provides a less invasive, accurate alternative to urinalysis should a urine specimen be unobtainable. Use of saliva as a testing matrix is also advantageous because there is decreased potential for sample adulteration. In recent years, methods for analysis of oral fluid have been published utilizing the Ultra High Pressure LC technology and solid phase extraction (SPE) as a sample preparation technique. Avoiding SPE would save hours of preparation, increase efficiency and reduce cost. We present a validated method developed to test 30 commonly prescribed and abused compounds in oral fluid without utilizing SPE in sample preparation.

Materials and Methods: Saliva samples were prepared for analysis by removing existing protein with acetonitrile spiked with internal standards. Samples were vortexed and then centrifuged at 220 x g for 10 minutes. The supernatant was removed, filtered and injected onto the UHPLC/MS/MS. Saliva samples were fortified with alprazolam, amphetamine, benzoylecgonine, cocaine, codeine, diazepam, dihydrocodeine, EDDP, fentanyl, hydrocodone, hydromorphone, α -hydroxyalprazolam, MDMA, methadone, methamphetamine, 6MAM, morphine, nordiazepam, norhydrocodone, noroxycodone, oxazepam, oxycodone, oxymorphone, PCP, phentermine, propoxyphene, and Δ^9 -THC. Mobile phases of water (A) and methanol (B) were used, each with 2.5mM ammonium formate and 2.5mM ammonium acetate. All samples were run on a Pinnacle DB 1.9 μ m 100 x 2.1mm column (Restek) with an Ultra Shield UHPLC Pre-Column (Restek) and Acquity Inline Filter (Waters).

Results: Using this method, we have been able to improve separation and resolution, especially among the isobaric compounds tested for in the saliva matrix. The linearity of all compounds was at least 0.995 (R^2). A series of 30 injections gave a %RSDs of under 20%. The lower limits of detection (LLOD) and quantitation (LLOQ) are superior to our previous method, with most detected at less than 5ng/mL. In conclusion, a new method was developed to test 30 compounds in the saliva matrix using UHPLC/MS/MS technology that saves time and expenses in sample preparation, and is specific, robust and applicable to the pain management and addiction management treatment industries.

Key Words: Saliva, Advanced Toxicology, UPLC/MS/MS

Certification of Reference Materials: Purity Analysis of Morphine-3 β -D-Glucuronide by Quantitative NMR, Enzymatic Hydrolysis LC-MS/MS Assay, and Mass Balance Purity Factor

Huahua Jian*, Martha Liu, Uma Sreenivasan and Isil Dilek
Cerilliant Corporation, Round Rock, Texas, USA

Introduction: Many drugs are rapidly and extensively metabolized to their glucuronide conjugates for excretion. Detection and quantitation of drug glucuronides is an essential part of forensic and toxicologic analyses. Test results have potential social, legal and clinical significance. The purity value assigned to these reference materials therefore has a critical impact on the quality of analytical results. As a class, glucuronides tend to be polar, hygroscopic, difficult to manufacture and handle, and they can be challenging to analyze and certify. Method of certification is critical and depends on the material to be tested.

Objective: A comparative evaluation of different approaches to certification of drug reference materials. Morphine-3 β -D-glucuronide (M3G) was used as an example to demonstrate drug glucuronide purity analysis by different methods.

Materials and Methods: M3G was synthesized at Cerilliant Corporation. The purity of M3G was determined by three different methods: 1) Quantitative ^1H NMR (qNMR) analysis by comparison to a NIST-traceable universal reference standard; 2) Hydrolysis of M3G by glucuronidase enzyme followed by assay using LC-MS/MS traceable to a morphine reference standard; 3) Mass balance/purity factor analysis by adjusting for chromatographic purity, residual water, residual inorganic and residual volatile organic content.

Results: M3G was synthesized and certified for use as the reference material with chromatographic purity of 99.5%. The certification results are as follows: 1) Primary component purity by qNMR is 90.6%; 2) Assay by enzyme hydrolysis is 89.3%; 3) Residual water content is critical for mass balance/purity calculation as M3G is hygroscopic and handling can influence results (by any method). Each technique has advantages and disadvantages related to certification of reference materials that are in general difficult to produce and handle. qNMR is a powerful tool for quantitation provided key considerations are factored into sample preparation, weighing and solubility. qNMR provides a purity value but does not present details on residual impurities such as water content which can be important for a reference material over time. LC-MS/MS of the parent drug after hydrolysis can provide comparison to a known reference standard.

Conclusion: The different approaches to certification of M3G are applicable to a variety of reference standards. The method of certification of a reference material must take into consideration sample handling, stability, hygroscopicity, chromatographic properties and availability.

Key Words: qNMR, Glucuronide, LC-MS/MS

A Combined Method for the Analysis of Barbiturates and 11-nor-9-carboxy- Δ^9 -THC in Urine by LC/MS/MS

Heather Workman, **Erica A. Guice***, and Matthew Montgomery
Western Slope Laboratory, Troy, MI, USA

Introduction and Objectives: Many laboratories are discovering the efficiency and ease of running larger advanced toxicology panels by liquid chromatography/tandem mass spectroscopy (LC/MS/MS) as opposed to the traditional screen then confirm model. Forgoing complicated sample preparation involving solid phase extraction (SPE) for a dilute and shoot methodology is another industry trend. The vast majority of the compounds in our 54-analyte advanced toxicology panel are run using positive mode; however, barbiturates and 11-nor-9-carboxy- Δ^9 -THC perform better in negative mode. Traditionally, these analytes would require separate sample preparation and two separate instrument runs. We developed an assay to combine five common barbiturates and a THC metabolite into one effective panel with minimal sample preparation.

Materials and Methods: Urine samples were centrifuged at 220 x g for 5 minutes before being hydrolyzed. The samples were then diluted with a 50:50 water:methanol mixture spiked with the internal standards 11-nor-9-carboxy- Δ^9 -THC- d_9 and pentobarbital- d_5 from Cerilliant. Barbiturates tested were: butabarbital, butalbital, pentobarbital, phenobarbital, and secobarbital. Samples were run utilizing electrospray ionization and negative MRM mode on a MicroMass Ultima coupled to an Alliance 2795 HPLC Autosampler. Separations were performed using a Pinnacle® DB C18 column 5 μ m 150mm x 2.1mm. The mobile phases consisted of water and acetonitrile with an ammonium hydroxide modifier. The run time was 10 minutes.

Results: Sample preparation was simple and efficient. Separation of the analytes was adequate. The linearity for all compounds was at least 0.995 (R^2), with a calibration range for the barbiturates of 0-5000 ng/mL, and 0-80 ng/mL for 11-nor-9-carboxy- Δ^9 -THC. A series of 30 injections gave a %RSD of under 16%. The lower limits of quantitation varies for the barbiturates between 10-100 ng/mL, while the LLOQ for 11-nor-9-carboxy- Δ^9 -THC was 3 ng/mL. No ion suppression studies were performed at this time. The results were comparable to our previous methods that involved running each compound class independently.

Conclusion: In conclusion, we were able to successfully combine two commonly run negative mode assays into one efficient panel with low limits of quantitation.

Key Words: Toxicology, Barbiturates, THC

Development of an Advanced Toxicology Method Utilizing Turbulent Flow Technology

Matthew W. Pentis*

Western Slope Laboratory Troy, MI, 48083 USA

Introduction: Advanced toxicology testing, specifically pain management and addiction testing, faces numerous challenges. First, many isobaric drugs (e.g. opiates) are difficult to separate and detect by liquid chromatography-tandem mass spectrometry (LC/MS/MS). Second, column life often is sacrificed when laboratories use simple “dilute and shoot” sample preparation techniques for urine. In addition, laboratories constantly are concerned about maintaining or improving lower limits of quantification (LLOQ) and detection (LLOD) as reported results depend on precise and valid quantifications at or near the LLOQ. Finally, an all-inclusive method to test for various drug classes would be of great benefit to the community. Here, we introduce a new LC/MS/MS method utilizing turbulent flow technology to test for several drug classes with only one TurboFlow HPLC column. This method yields improved separation, sensitivity and efficiency while retaining column life.

Objective: To obtain accurate and precise data through development of a new method utilizing turbulent flow technology to quantify multiple drug classes using only one TurboFlow column in < 10 min per sample with a LLOQ < 50 ng/mL for all compounds.

Materials and Methods: Urine samples were centrifuged, transferred to a 2 mL vial, hydrolyzed with 2.5% β -Glucuronidase Type HP-2 (approx 300 units of activity), incubated at 40°C for 1 h, and fortified with internal standards. Samples were then injected without further cleanup onto one turbulent flow column on a Thermo Scientific TLX^{MD} system with ammonium acetate, ammonium formate, and ammonium hydroxide in water. Next, analytes were transferred to an analytical column. Mobile phase consisted of water (pH 6.20) and methanol (pH 7.27) with ammonium formate and ammonium acetate at a gradient over three minutes to 98% organic followed by an isocratic elution for four minutes. Analytes were detected with an Applied Biosystems API QTRAP 2000 mass spectrometer utilizing positive electrospray ionization and multiple reaction monitoring. Compounds investigated include 4 amphetamines, 11 opiates/opioids (including propoxyphene), 6 benzodiazepines, 12 commonly-prescribed prescription medications, 11 tricyclic antidepressants and cocaine. Six internal standards were utilized for analyte quantification.

Results: Adequate separation and resolution was achieved with the advanced toxicology panel by the described method. Isobaric compounds were chromatographically resolved: specifically, hydrocodone/codeine, oxycodone/noroxycodone, methamphetamine/phentermine, and morphine/hydromorphone/norhydrocodone were all adequately resolved. All compounds demonstrated acceptable repeatability ($n = 30$, < 10% RSD) and linearity ($R^2 > 0.995$). 6 month injection repeatability yielded < 10% RSD for all compounds. LLOQ and LLOD were improved from our previous method (without turbulent flow technology) for all compounds and LLOD ≤ 5 ng/mL were achieved for most analytes.

Conclusion: A novel advanced toxicology method utilizing only one TurboFlow column was developed. The method is rapid, quantifying multiple drug classes in less than 10 min. The method has proven to be robust, sensitive, specific, and applicable in urine.

Key Words: Turbulent Flow, Pain Management, Urine

P029

Enterprise LIMS Data Exchange in Clinical, Toxicology, and Public Health Laboratories

Conor Ward*

ChemWare, Inc., Raleigh, NC, USA

Introduction and Objectives: One yardstick for the effectiveness of a LIMS (Laboratory Information Management System) implementation is the degree to which donor test requests, test results, and billing information are securely and seamlessly exchanged between disparate healthcare data systems and partners. This presentation reviews the myriad of enterprise systems and applications with which modern laboratories must integrate, and describes technology solutions for getting these systems to speak a common language.

Methods: Even in many highly automated laboratories, most demographic- and results-related data are still routinely captured by pen and paper, transcribed into computers by hand, and delivered to recipients by phone and fax. This is despite the fact that well-defined data exchange standards have existed in the healthcare industry for over twenty years. A typical clinical laboratory may need to connect with ten different submitter clinics, each of which uses a different electronic medical record (EMR) system for electronic test submission. That same laboratory must also exchange demographic and results information with reference laboratories, hospitals, medical review officers (MROs), and public health agencies, deliver secure results via the web, and send billing information to third party medical billing partners. In this presentation, we describe practical implementation examples and review the costs and benefits associated with integrated data exchange solutions across the healthcare enterprise. We will focus on laboratory automation improvements in:

- Electronic test request processing and reporting with hospitals, doctors and others in the healthcare industry;
- Screening analyzer and confirmation instrument integration;
- Remote collection site integration through a secure web portal;
- Electronic charge and billing information exchange with accounting systems and third-party billing partners.

Results and Conclusion: Standardization provides an opportunity to minimize the risks and high maintenance costs associated with customized “point” solutions. Additional benefits of an enterprise-wide data exchange solution include reduced operating expenses, fewer data entry and transcription errors, faster specimen processing and resulting turnaround, increased laboratory testing capacity, and the ability to shift labor to areas of the operation where scientists and clinicians can add more value.

Key Words: LIMS, Data Exchange, Laboratory Automation

P030

Urine Barbiturate Analysis Using an Improved SPE Protocol and LC/MS/MS; Achieving Chromatographic Resolution of Isobaric Amobarbital & Pentobarbital

Michael Rummel*, Matthew Trass, Seyed Sadjadi, Jeff Layne, Sky Countryman, and Erica Pike
Phenologix (Applied Applications Group), Phenomenex, Torrance, CA, USA

Objectives: Barbiturates are a notoriously difficult class of compounds to analyze in drugs of abuse testing panels. These neutral and fairly polar compounds are difficult to retain on conventional solid phase extraction (SPE) sorbents, limiting the wash strength and subsequent matrix clean-up. Additionally, two of the commonly screened barbiturates, pentobarbital and amobarbital share the same mass transitions meaning full chromatographic resolution is necessary for LC/MS/MS analysis. Achieving full resolution is a difficult task as the two barbiturates differ only in the position of a methyl group. Therefore, the goal of this work was to develop a streamlined SPE extraction for barbiturates in urine that removed potential matrix contaminants and a LC/MS/MS method that resolved pentobarbital, amobarbital, butalbital, secobarbital, and phenobarbital. Much emphasis was placed on the sensitivity and reproducibility of the method over a linear range from 40-125% of the cutoff concentration set at 300 ng/mL.

Methods: Solid phase extraction was performed using a 100 mg/6 mL Strata-X-Drug N polymer-based sorbent. The Strata-X-Drug N sorbent does not require conditioning resulting in a method that allowed for direct sample loading, initially reducing the number of steps of conventional SPE. The pre-treated sample was loaded directly by applying a light vacuum to solvate bed and frits. The vacuum was then turned off and samples were allowed to gravity flow through the sorbent. 2 washes were then applied; 2 mL of 0.1 N HCl followed by 2x 2 mL of methanol:0.1 N HCl (30:70). The sorbent was allowed to dry for 10 minutes at full vacuum to remove any excess wash solvent that may have been present. The extracted barbiturates were eluted with 2 mL of ethyl acetate:isopropanol (85:15) which was evaporated to dryness under a stream of N₂ at 50 °C. Samples were reconstituted in 1 mL of 10 % acetonitrile and injected onto a Kinetex Core-Shell 2.6 µm C18, 50 x 2.1 mm HPLC column using a shallow gradient of 10-45% acetonitrile over 10 minutes.

Results: Extracted urine calibration curves established method linearity over 120 ng/mL, 300 ng/mL, and 375 ng/mL concentrations (n=3 at each concentration), while recovery values were measured to evaluate extraction performance. For all five of the barbiturates, correlation coefficients ranged from 0.989-0.998, absolute recovery ranged from 89.7-102.6%, and RSD values from 0.96-6.70%. Inter-assay accuracy and imprecision (3 different days) ranged from 99.06 – 102.07% and 4.91-6.39% respectively. Method LLOQ was set at 10ng/mL with a S/N ratio of > 100 for all analytes.

Conclusions: In addition to the aggressive and streamlined extraction procedure, the LC/MS/MS results using the Kinetex 2.6 µm C18 column provided excellent separation of all barbiturates. More importantly, resolution of the structural isomers, pentobarbital and amobarbital, was achieved. These two compounds have been historically difficult to analyze using LC/MS/MS because of their identical m/z values and chemical composition.

Key Words: Drugs of Abuse, SPE, LC/MS/MS, Barbiturates, Phenobarbital, Butalbital, Pentobarbital, Amobarbital, Secobarbital

The Application of HILIC Stationary Phase in Analysis of Anticonvulsants in Whole Blood by Means of NPLC-MS/MSWojciech Lechowicz^{*1} and Dawid Nieć²¹Institute of Forensic Research, Kraków, Poland; ²Jagiellonian University, Kraków, Poland

Objectives: Chemistry of Hydrophilic Interaction LIquid Chromatography (HILIC) stationary phase gives the opportunity of applying polar (aqueous) mobile phases suitable for mass spectrometric detection. Based on the analysis of anticonvulsants, some aspects of HILIC column properties are enlightened.

Materials and Methods: The method for the detection and quantitation (positive Multi Reaction Monitoring mode (MRM)) of carbamazepine (237→220; 237→194), oxcarbazepine (253→208; 253→180), pregabalin (160→142; 160→97), gabapentin (172→154; 172→137), vigabatrin (130→71; 130→113), tiagabine (376→247; 376→278), clonazepam (316→270; 316→241), levetiracetam (171→154; 171→126), lamotrigine (256→211; 256→109), phenytoin (253→225; 253→182), felbamate (239→117) by Normal Phase Liquid Chromatography Mass Spectrometry (NPLC-MS/MS) is presented. Extraction of these drugs was performed using Oasis® HLB columns (Waters) followed by separation on SeQuant ZIC®HILIC 150 x 4.6 mm column (Merck) and mass detection in ESI (Quattro Micro Mass Spectrometer, Waters) mode. Two internal standards, clonazepam-D4 (320→274) and trimipramine (295→100) were used for quantitation. Isocratic conditions for separation (80:20 acetonitrile (ACN):water with addition of formic acid 0.1% v/v) applied.

Results: Based on experimental data a mathematical equation was formulated for the prediction of retention times of the analytes. The method was validated. Matrix effects were investigated using continuous infusion of standards during blank blood sample analysis. No suppression or enhancement of the signals was detected. Stability of retention times was better than 1% for all analytes. This finding is in opposition to opinions of poor reproducibility of retention times on HILIC columns. Limits of quantitation were set to therapeutic levels of appropriate drugs. Inaccuracy and imprecision for LLOQ and ULOQ were <25%. The calibration curves were linear within those ranges ($R^2 > 0.960$). Very high therapeutic blood concentrations of some anticonvulsants required the dilution of samples.

Discussion and Conclusions: The increase of ACN content in the mobile phase caused an enhancement of signal intensity along with an increase of retention times. This is opposite to the behavior of compounds if classical reversed phase C-8 or C-18 columns are utilized. This phenomenon is very important for cases of poorly ionizable analytes. The benefits of using HILIC columns in forensic toxicology are the reduction of matrix effects and an enhancement of the analyte's signal intensities. This type of chromatographic column is suitable not only for polar compounds but also for compounds with moderate polarity.

Key Words: HILIC, Anticonvulsants, Blood

P032

Quantitative Analysis of Carboxy-THC in Urine Using UPLC[®]-MS/MS

Rob Lee^{1,*}, Jane LeCount², Allan Traynor² and Michelle Wood¹

¹Waters Corporation, MS Technologies Centre, Manchester, England, UK; ²Concateno, London, England, UK

Introduction: Cannabis is the most widely used illicit substance in the world and long-term use can lead to dependency. Cannabinoids are one of the most commonly detected classes of illegal drugs; consequently their analysis is of key importance in both forensic and workplace testing. The aim of this research was to develop a UPLC-MS/MS method for the quantitation of carboxy-THC in human urine.

Methods: To ensure complete hydrolysis of any conjugate to the free acid, the urine samples were first hydrolyzed. Deuterated d₃ carboxy-THC internal standard was added to 0.5mL of urine along with 15μL 10M sodium hydroxide and the samples were incubated for 30 minutes at 70°C. Following acidification with 85μL glacial acetic acid the samples were prepared by liquid/liquid extraction using a hexane/ethyl acetate (9:1 v/v) mixture. The extracted analytes were separated on a Waters ACQUITY UPLC system using an ACQUITY UPLC BEH C18 column (1.0 x 50mm, 1.7μm) eluted with 5mM ammonium acetate containing 0.05% formic acid and methanol as mobile phases, and a chromatographic run-time of 7.0 minutes. Carboxy-THC was detected using a Waters XEVO TQ MS in MRM mode with electrospray ionization in positive mode. The parent ion was 345.2 and the product ions were 193.2 and 299.1 for quantifier and qualifier respectively. Seventy five authentic human samples were analysed by this UPLC-MS/MS method and results were compared to those obtained with GC-MS.

Results: The developed method was evaluated for intra-day and inter-day accuracy, precision, linearity, recovery, matrix effects and extracted sample stability. Over a five day study the r² values for linearity from 1 to 500ng/mL were all above 0.995. The intraday quality control coefficient of variance was less than 5% while the inter-day values were less than 7% (all values obtained were within 3% of target). Recovery ranged from 60 to 71% and matrix effects ranged from -26% to -9%. For the 75 authentic samples there was excellent correlation between the UPLC-MS/MS results and previous results by GC-MS with correlation (r²) values of above 0.95. The limit of detection for the assay was determined to be 1ng/mL.

Conclusions: This work presents a sensitive and reliable method for analyzing carboxy-THC in urine.

Key Words: Carboxy-THC, Urine, UPLC[®]-MS

Analysis of Amphetamines and Ephedrines in Urine using Solid Phase Extraction and Direct Mass Spectrometry

Hiroyuki Inoue*¹, Hiroaki Hashimoto², Yukiko Nakazono¹, Hajime Miyaguchi¹, Kenji Kuwayama¹, Kenji Tsujikawa¹, Tatsuyuki Kanamori¹, Yuko T. Iwata¹ and Hirofumi Fukushima¹

¹National Research Institute of Police Science, Kashiwa, Chiba, Japan; ²Hitachi High-Tech Control Systems Corporation, Mito, Ibaraki, Japan

Objectives: As recreational drug use increases, it is necessary that rapid and reliable methods for drug urinalysis are available. In this study we describe, direct mass spectrometry (MS) coupled with counter-flow introduction atmospheric pressure chemical ionization (CFI-APCI) for the rapid screening of amphetamines and ephedrines in urine after solid phase extraction.

Materials and Methods: Urine (0.5 mL) was spiked with amphetamines (methamphetamine, amphetamine, 3,4-methylenedioxymethamphetamine [MDMA] and 3,4-methylenedioxyamphetamine [MDA]), ephedrines (ephedrine, methylephedrine and norephedrine) and methamphetamine-*d*₅ as an internal standard before mixing with 0.5 mL of 0.1 M HCl. The sample was poured onto preconditioned Oasis MCX cartridges (Waters Corporation, Milford, MA) and washed with 1 mL of 0.1 M HCl and 1 mL of acetonitrile. Analytes were eluted with 1 mL of acetonitrile containing 5% ammonium hydroxide. A portion of the eluate (100 µL) was spotted onto a glass-microfiber filter and introduced to a Hitachi DS-1000 ion-trap mass spectrometer equipped with a CFI-APCI ion source.

Results: Immediately after introduction of the glass-microfiber filter to the instrument, large increases in total ion current were observed in MS full scan mode. Tandem MS analysis revealed characteristic product-ion mass spectra for identification of the analytes. For example, collision-induced dissociation of the protonated molecule of methamphetamine (*m/z* 150) produced characteristic product ion fragments of *m/z* 119 and 91. Solid phase extraction recoveries from urine with the Oasis MCX cartridge were 81.5–96.5% at 0.5 µg/mL and 91.8–98.8% at 10 µg/mL for all seven analytes. The lower limits of detection were estimated to be in the range of 0.15–1 µg/mL (signal-to-noise > 3 on MS/MS traces).

Conclusion: This method would be useful for the rapid screening of amphetamines and ephedrines in urine as analysis times were less than 1 minute, and continual analysis could be performed every 2 minutes.

Key Words: Amphetamines, Ephedrines, Urine, Direct Mass Spectrometry

Benefit From the Use of Deconvolution Reporting Software (DRS) and the Forensic Toxicology DataBase Library Combined with Retention Time Locking (FT-DBL-RTL) in Toxicological Screening with GCMS in a Forensic Laboratory**Wenche R.Brede**^{*1}, Kjell Aarstad¹, Kolbjørn Zahlsten²¹St.Olavs University Hospital, Trondheim, Norway; ²SINTEF, Materials & Chemistry, Trondheim, Norway

Objectives: Gas chromatography - mass spectrometry (GCMS) is a frequently used technique in laboratories performing toxicological screening for pharmaceuticals, toxins and drugs of abuse in biological samples. However, it is a challenge to identify unknown compounds in complex samples with co-eluting substances and low analyte-concentrations. Deconvolution Reporting Software (DRS) can extract spectra from interfering and overlapping peaks. The extracted spectra can subsequently be matched to a reference spectrum database. The present study investigates the benefit from the use of DRS and the Forensic Toxicology Database library combined with retention time locking (FT-DBL-RTL).

Materials and Methods: In the present study 167 forensic blood samples were treated by acidic (0,75M NaH₂PO₄ pH 3,0) and alkaline (0,75M Na₂CO₃ pH 11,0) liquid-liquid extraction (LLE) (dichloromethane/isopropanol) from 1 mL blood. Samples were injected and analysed on two identical GCMS instruments, Agilent GC 6890 and MSD 5973 with electron ionization (EI). The columns were J&W Scientific, Agilent, HP5-30m and DB5-15m for the conventional and the deconvolution method, respectively. Both columns had a 0,25mm diameter and 0,25µm film thickness. In both methods the conventional Chemstation Problem Based Matching (PBM)-software were used making search against libraries NIST05 and PMW_TOX possible.

Results and Conclusions: By the use of deconvolution methodology, FT-DBL-RTL, 355 compounds were identified on the DB5-15m column, compared to 226 compounds by use of the conventional method with an HP5-30m column. The identified compounds were anaesthetics, analgesics, antiepileptics, anxiolytics, hypnotics, sedatives, antipsychotics, centrally acting muscle relaxants and antidepressants. Compounds like caffeine or nicotine are not included. By use of the deconvolution methodology on both columns comparing samples with different results between deconvolution and conventional methodology (77 of 167 samples), 273 compounds were identified on a DB5-15m column and 224 compounds were identified on an HP5-30m column. The benefit of the shorter column was most pronounced at low concentrations. No differences were observed in the number of identified compounds between column lengths when using the conventional method on both columns. The deconvolution methodology, FT-DBL-RTL, and the use of a 15m column reduced the time of analysis from 24 to 14 minutes compared to the conventional method. The total time, instrument-and reporting time, was reduced from 39 to 17 minutes.

Key Words: Deconvolution, GCMS, Forensic Blood

Evaluation of Solid-Phase Extraction Cartridges for the Quantification of THC-COOH in Urine Using Gas Chromatography-Mass Spectrometry

Huey Sze Leong*, Ngak Lee Lee, Yi Ju Yao and Chi Pang Lui

Analytical Toxicology Laboratory, Illicit Drugs & Toxicology Division, Applied Sciences Group, Health Sciences Authority, Singapore

Objectives: To evaluate two different types of solid-phase extraction (SPE) cartridges for the extraction of 11-nor- Δ^9 -tetrahydrocannabinol-9-carboxylic acid (THC-COOH) in urine.

Materials and Methods: A polymeric mixed mode cationic sorbent, Phenomenex Strata™ X-C and a silica mixed mode anionic sorbent, Varian Bond Elut® Certify II cartridges were compared. The extracts were analyzed using gas-chromatography-mass spectrometry (GC-MS) in selected ion monitoring (SIM) mode. Method validation parameters included linearity, accuracy, repeatability (intra-day precision), reproducibility (inter-day precision), extraction efficiencies, stability, robustness and specificity.

Results: Linearities of up to 2000 ng/mL were obtained with correlation coefficients of $r^2=0.9949$ for Bond Elut® Certify II and $r^2=0.9995$ for Strata™ X-C. Limit of detection (LOD) and quantification (LOQ) were 2 ng/mL and 5 ng/mL, respectively for both cartridges. Accuracy was 98.8 – 115.8% and 100.6 – 105.3% at three concentrations (15, 100 and 500 ng/mL) for Bond Elut® Certify II and Strata™ X-C, respectively. Inter-day imprecision ranged from 2.1 - 3.1% and 2.9 - 6.6% for Bond Elut® Certify II and Strata™ X-C, respectively. Intra-day imprecision was less than 2.0% for Bond Elut® Certify II and less than 2.3% for Strata™ X-C cartridges. Extraction efficiencies of 67.2 – 74.2% and 75.9 – 82.4% at three concentrations (15, 100 and 500 ng/mL) were obtained for Bond Elut® Certify II and Strata™ X-C, respectively. The SPE methods were found to be robust and specific. Each SPE method was also compared to our current liquid-liquid extraction (LLE) procedure which uses hexane/ethyl acetate (7:1) as the extracting solvent. Good correlations, $r^2>0.970$ and $r^2>0.980$ were obtained (n=90) for Bond Elut® Certify II and Strata™ X-C, respectively.

Conclusion: Both cartridges were found to be equivalent in terms of extraction efficiencies, precision and sensitivity. Hence, they are suitable for the quantitative analysis of THC-COOH in urine.

Key Words: THC-COOH, Urine, SPE Cartridges

Simple Urine Screening for the Determination of Selected Benzodiazepines by Direct Injection LC/ESI-MS

Constantinos Pistos, Sevasti Karampela, Ioanna Vardakou, Ioannis Papoutsis, Artemisia Dona, **Sotiris Athanasis*** and Chara Spiliopoulou

Laboratory of Forensic Medicine and Toxicology, Medical School, University of Athens, Athens, Greece

Objectives: The aim of this study was the development and validation of a Liquid Chromatography Mass Spectrometer (LC/MS) method for the simultaneous determination of selected benzodiazepines in human urine with limited sample preparation allowing for its direct application as a screening method replacing existing immunoassays.

Materials and Methods: Diazepam, nordiazepam, flunitrazepam, 7-aminoflunitrazepam, flurazepam, bromazepam, clonazepam, midazolam, nitrazepam, alprazolam, temazepam, oxazepam, prazepam, medazepam and triazolam were selected for determination. Oxazepam-d5 was used as the internal standard. Chromatography was performed using an LC/MS 2010EV system consisting of an LC 20AB pump equipped with a DGU 20A₅ degasser, SIL 20AC autosampler and a 2010EV single quadrupole mass spectrometer with electrospray ionization (ESI) source operated in the positive mode. SIM acquisition mode was chosen for the determination of all analytes. Chromatographic separations were achieved on an X'Terra C8, analytical column (250 mm x 2.1 mm i.d., 5µm) using a gradient program and a mobile phase of 0.05% formic acid /acetonitrile. The flow rate ranged between 0.25 – 0.4 mL/min, the column temperature was set at 30 °C and the injection volume was 10 µL.

Results: All benzodiazepines were successfully separated allowing for their detection at low levels without interferences from the matrix. The main advantage of the proposed methodology is use of a low sample volume, 0.5 mL, and the simple preparation procedure that allows diluted urine samples to be filtered through a Millex-HV Durapore membrane (0.45µm) then directly injected into a single quadrupole mass spectrometer. The run time was 20 min using a gradient LC programme and the tested linearity ranged from 50 – 1000 ng/mL ($r^2 > 0.99$). LOD and LOQ were calculated to be 16.7 and 50 ng/mL, respectively. Inaccuracy was found to be less than 9.4% while imprecision was less than 5.5% for all compounds. The method was further applied in real samples and proved to be suitable for a simple initial screening of these analytes during the investigation of clinical or forensic cases, replacing the existing immunoassay methods for benzodiazepines and offering higher selectivity and sensitivity.

Conclusion: A direct injection LC/MS method was developed and validated for the screening of selected benzodiazepines in urine. The main advantage of the proposed methodology was the lack of an extraction step, as diluted urine samples were filtered then directly injected into the LC/MS system. Chromatographic run time was less than 20 min. The linearity, accuracy and precision results prove the suitability of the method for the investigation of Clinical and Forensic Toxicology cases. The above method may be validated for quantitative analysis of real samples.

Key Words: Direct Injection; Benzodiazepines; LC/MS

P037

Method Optimization for the GCMS Determination of Amphetamines and Amphetamine-like Derivates in Urine Using On-line Trifluoroacetylation

Péter A. Fábrián*, Előd Hidvégi, Gábor P. Somogyi.

National Institute of Forensic Toxicology, Budapest, Hungary

Objectives: The aim of this work was to develop and optimize a previous method by modifying the extraction and GCMS analysis parameters to achieve a faster, more economical and reliable procedure.

Materials and Methods: We originally used a one step alkaline liquid-liquid extraction with toluene to determine amphetamine, methamphetamine, MDA, MDMA, MDEA and ephedrine from urine. Methoxyphenamine was used as internal standard. The extraction procedure was as follows: 250 μ L potassium hydroxide and 0.7 g sodium sulphate was added to 3 mL urine and extracted with 3 mL toluene. Toluene was evaporated at 60 °C to approximately 100 μ L and a 1:5 split injection was introduced to the GCMS via on-line trifluoroacetylation (1 μ L sample combined with 1 μ L MBTFA). The injection port was maintained at 270°C, initial oven temperature of 90 °C was held for 1 min, with ramps of 20°C/min to 200 °C, and 30°C/min to 290°C, with a final hold time of 5 minutes.

Retention times, peak areas and in certain instances RSD% of the peak areas were monitored during method optimization. In optimizing the method, we examined if the amount of urine or solvent could be reduced, evaluated evaporation of the extraction solvent to dryness, and investigated off-line derivatization. GCparameters including column flow, split flow ratios and the number of ions monitored in each group were optimized.

Results and Conclusion: The results of the modification steps showed that reducing the amount of toluene and evaporating the solvent to dryness, combined with decreasing the split flow rate and on-line trifluoroacetylation with less ions monitored per compound group and an improved oven temperature resulted in a more efficient determination of the investigated compounds. The optimal parameters are as follows: sample volume : 3 mL urine, extraction solvent: 1 mL toluene, split flow rate: 1:4, GC oven temperature program: 100°C for 1 min, 30°C/min to 190°C, 20°C/min to 280°C and 40°C/min to 320°C, hold for 2 min. These settings provided 171-463% increased peak areas at 300 ng/mL and reduced GC/MS analysis time by 4 minutes (from 13 to 9) compared to the original method. Linearities were investigated between 50 and 2000 ng/mL and the r^2 for amphetamine (0.999), phentermine (0.999), ephedrine (0.997), methamphetamine (0.999), pseudoephedrine (0.996), PMA (0.998), MDA (1.000), PMMA (0.999), MDMA (1.000) and MDEA (0.995) exceeded laboratory requirements (>0.995). Changing the amount of urine (3 ml) and column flow rate (0.8 ml/min) did not improve results.

In addition, this method could also be used to analyze other amphetamines such as PMA, PMMA and amphetamine-like derivatives phentermine and pseudoephedrine.

Key Words: Optimization, MBTFA, Amphetamines, GC/MS

P038

Analysis of Drugs of Abuse by GC-MS in Dried Blood Spot Sample Matrix

Kaarina Langel, Hannu Uusivirta, Kari Ariniemi and **Pirjo Lillsunde***

National Institute for Health and Welfare, Mannerheimintie 166, FI 00300 Helsinki, Finland

Objectives: The easy sampling and handling of dried blood spots (DBS) makes them an interesting alternative to traditional blood sampling. DBS samples have been used in clinical settings for decades but very few applications are published for drugs of abuse. The objective of this study was to develop a quantitative method for analysing 23 drugs of abuse from DBS samples with gas chromatography mass spectrometry (GC/MS). The drugs analysed include amphetamines, opiates, cocaine, cannabis, zopiclone, and benzodiazepines.

Methods: DBS (100 μ L of spiked or case blood) containing the analytes were cut into smaller pieces and 500 μ L of saturated borate buffer (pH 10) and 2 mL of butyl acetate (BuAc), with deuterated internal standards, were added. The samples were mixed and centrifuged, and the solvent was divided for two separate analyses (A and B). The fractions were evaporated to dryness at 75 $^{\circ}$ C, reconstituted in 30 μ L BuAc:ACN 1:1 and derivatized with 10 μ L MTBSTFA/MSTFA (fraction A/B). GC conditions were as follows: splitless injection mode. Fraction A: GC-NCI/MS with DB-5HT column (30.0m x 320 μ m x 0.10 μ m) injection port temperature 300 $^{\circ}$ C; helium as carrier gas; column temperature 160 $^{\circ}$ C (0.7 min) increased to 330 $^{\circ}$ C at 50 $^{\circ}$ C/min (0.4 min). Fraction B: GC-EI/MS with DB-5MS column (15.0m x 250 μ m x 0.25 μ m); injection port temperature 300 $^{\circ}$ C; oven temperature 120 $^{\circ}$ C increased to 213 $^{\circ}$ C at 30 $^{\circ}$ C/min, at 40 $^{\circ}$ C/min to 240 $^{\circ}$ C, at 30 $^{\circ}$ C/min to 289 $^{\circ}$ C and at 50 $^{\circ}$ C/min to 330 $^{\circ}$ C; hydrogen carrier gas. Total run times for fractions A and B were 4.5 min and 7.8 min, respectively.

Results: The linear concentration range ($R^2 > 0.98$) in ng/mL was 5-100 for THC and buprenorphine, 5-250 for lorazepam, 5-500 for alprazolam, clonazepam and THC-COOH, 10-1000 for codeine, morphine, methadone, zopiclone, midazolam and nitrazepam, 20-2000 for amphetamine, methamphetamine, MDA, MDMA and nordiazepam, 20-1000 for phenazepam, 50-1000 for cocaine, 50-5000 for diazepam, temazepam and tramadol, and 50-1250 for oxazepam. The intra- and inter-day imprecision and inaccuracy were tested at three concentration levels and they were within the required limits (<15% and <20% at LOQ). Extraction recoveries were >75% for all but THC (41%), THCCOOH (32%), morphine (50%), and buprenorphine (50%).

Conclusion: This sensitive and simple analysis method enables determination of 23 drugs of abuse and medicinal drugs from a low volume DBS sample by GC-MS. The drugs found in whole blood were also found in DBS.

Key Words: Blood Spot, Drugs, Analysis

Protein Adduct Based Biomarkers of Chemical Warfare Agents: Characterization of HN-2 and HN-3 Adduction of Model Peptides

Vanessa Thompson* and Anthony P. DeCaprio

Department of Chemistry and Biochemistry and International Forensic Science Research Institute, Florida International University, Miami, FL, USA

Introduction and Objectives: Covalent reaction products (*i.e.*, “adducts”) are formed when electrophilic xenobiotics bind to nucleophilic residues on amino acids in biological proteins. Adducts that are stable may be used as biomarkers of past, long-term, or cumulative exposure to xenobiotics of interest. Previous research has demonstrated that the three most important protein nucleophiles are cysteine (Cys), lysine (Lys), and histidine (His), making them good targets for xenobiotic binding. The chemical warfare agents (CWA) HN-2 and HN-3 are classified as blister agents, which cause tissue blistering along with ocular and respiratory damage. The use of protein adducts as biomarkers of exposure to these compounds can, in theory, allow for detection long after urinary metabolites and/or the parent compounds have been excreted from the body. The aim of this work was to characterize adducts of HN-2 and HN-3 to Cys-, Lys-, and His-containing peptides in an *in vitro* model system. Adduct formation was analyzed by means of tandem mass spectrometry (LC-MS/MS).

Methods: Various experiments were performed to assess 1) the kinetics of adduct formation with each model peptide, 2) the relationship between CWA concentration and resultant adduct stoichiometry, 3) chemical structure of the adducts, and 4) the stability of adducts over time. All experiments were performed using samples at pH 7.4 and incubated at 37°C to mimic physiological conditions. Analysis was performed on an Agilent 6490 triple quadrupole LC-MS/MS with UHP 1290 Infinity UHPLC using a ZORBAX Eclipse Plus C-18 Rapid Res HD (10 mm x 2.1 mm, 1.8 µm particle size) column. Gradient elution with water and acetonitrile containing 0.1% TFA as the mobile phases was employed.

Results: HN-2 and HN-3 adduction occurred with all three model peptides within 20 minutes of incubation at 37°C. MS/MS data and isotopic ratios demonstrated that adduction occurred via the loss of chlorine on one of the 2-chloroethyl chains and subsequent adduction to each nucleophilic site. For both HN-2 and HN-3, adduction was observed when the ratio of mustard-to-peptide was 50:1 or higher. When comparing the relative reaction rates of the three model peptides, Cys adducts were found to form more rapidly than those with Lys and His. Peptide adducts formed were stable over four weeks when incubated at 37°C.

Conclusion: Previous research has demonstrated that adduction of HN-2 and HN-3 occurs on proteins such as serum albumin and metallothionein. The present study confirms earlier observations that HN-2 and HN-3 can form adducts to free thiol groups and also demonstrates that these agents may bind other nucleophilic residues (specifically Lys and His) on proteins. These alternative sites of binding may provide additional useful biomarkers of exposure to these compounds. Future work will assess *in vitro* and *in vivo* binding of HN-2 and HN-3 to hemoglobin and serum albumin as potential exposure biomarkers.

Key Words: Nitrogen Mustards, Biomarkers, Protein Adducts

High Mass Accuracy LC-MSMS Instrumentation with Improved Identification Software to Screen Compounds of Forensic Interest

Anastasia Chasapi¹, **Olivier Philippe**^{1,*}, Roman Mylonas¹, Alexandre Masselot¹, Nicolas Budin¹, Pierre-Alain Binz^{1,2}
¹Geneva Bioinformatics (GeneBio) SA, Geneva, Switzerland; ²Swiss Institute of Bioinformatics, Geneva, Switzerland

Objectives: Liquid chromatography tandem mass spectrometry (LC-MSMS) combined with a library search is a qualitative screening method increasing in popularity in various fields such as clinical toxicology, forensic toxicology and food testing. Although identifying compounds with gas chromatography mass spectrometry (GC-MS) and processed via spectral library search has been a widely adopted approach for many years, LC-based approaches provide access to a broader set of analytes. Classical algorithms have performance limitations due to the variability of generated spectra by LC-MSMS and the poor molecular coverage of libraries. However, the algorithm implemented in SmileMS efficiently overcomes these difficulties. Here we show the additional advantage of using high mass accuracy signals from full scan MS1 spectra to provide increased confidence in identifications from LC-MSMS data.

Materials and Methods: MS1 scans and MSMS product ion scans from compounds of interest were acquired with high mass accuracy on a AB Sciex TripleTOF 5600 (Foster City, CA, USA). The extracted MSMS spectra were submitted to SmileMS in high and low precision mode, using a stringent mass filter on the molecular ion m/z while searching a high and a low mass accuracy library. Extracted ion chromatograms (XICs) of the corresponding MS1 precursors m/z and their first isotopes were generated for the molecules identified. Consolidated isotopic ratios were calculated and compared with theoretical values to validate the hits. Identifications were also performed without using the molecular ion mass filter. This mode allowed for the identification of metabolites and other compounds absent in the library but similar by spectral similarity metrics only. Similar analyses were carried out with patient sample data acquired on an AB Sciex 3200 QTRAP, a low mass accuracy instrument.

Results: The combination of high mass accuracy precursor m/z filter, high mass accuracy scoring and high mass accuracy MS1 isotopic profiles displayed the highest specificity. The MSMS-based results were generally confirmed with the MS1 data. A tolerance of 0.01 Da on precursor m/z , a tolerance of 0.04Da on fragments, a filter of 0.002Da to generate XICs and a tolerance of $\pm 2.5\%$ in isotopic ratio were conservative values for the 5600 dataset. The positions on the XICs where the MSMS spectra identified the corresponding compound constituted an informative observation together with the consolidated isotopic profile matches, to validate and sometimes exclude hits obtained from the MSMS data analysis. This contributed to a decrease in possible false positive hits. In a targeted analysis mode, even if a MSMS score is not available (fragmentation not triggered or low quality spectrum), the MS1 data is available to identify a compound. As expected, isotopic profiles obtained from low mass accuracy instruments were less precise and corresponded to a less stringent filter to sort out low quality hits.

Conclusions: We showed that SmileMS can efficiently take advantage of high mass accuracy MSMS data to identify molecules of forensic interest. In addition, the use of MS1 data further reduced the number of remaining false positives. This approach is applicable to all high mass accuracy instruments, such as QqTOFs and LTQ-Orbitraps. It also has the potential to validate identification of similar compounds absent from libraries (metabolites, derivatives, etc).

Key Words: LC-MSMS, Library Search, Accurate Mass

Proof of Concept for Drug Screening Using a High Resolution Accurate Mass System

Alexandre Wang^{*1}, Gregory Newland¹, Witold Woroniecki¹, Jeffery Rivera², and Hua-fen Liu¹

¹AB Sciex, Foster City, California, USA; ²AB Sciex, Concord, ON, Canada

Objectives: We evaluated the use of a fast, high resolution, accurate mass detection system capable of generating time-of-flight mass spectrometry (TOF-MS) data with up to 20 product ion spectra in under one second. We also evaluated the use of a product ion spectra library generated on a hybrid triple quadrupole ion trap system with the data generated from the high resolution accurate mass system.

Methods: Blood samples (250µL) were precipitated with the addition of 750µL of acetonitrile. Samples were then vortexed, centrifuged and the supernatant evaporated, before reconstitution with 500µL of 10:90 acetonitrile:water. Urine samples were diluted with 5 volumes of 10:90 acetonitrile:water. Separation was carried out on a Restek Allure PFP Propyl 50mm x 2.1mm x 5µm column. Mobile phase A consisted of 0.2% formic acid and 2mM ammonium formate in water and mobile phase B consisted of 0.2% formic acid and 2mM ammonium formate in acetonitrile. A linear gradient starting at 10% organic and ending at 90% organic was used with a total flow rate of 0.7mL/min and a total run time of 17.5 min. The drug screening method consisted of a TOF-MS survey scan with Information Dependent Acquisition (IDA)-triggering of up to 20 product ion scans. Total cycle time for the TOF-MS-IDA-Product Ions (20) was approximately one second. The product ions were automatically searched against a library generated on the QTRAP® System.

Results and Conclusion: Positive blood and urine samples were used for the evaluation of the method and library search tool. High concentrations of antidepressants, pain medications or drugs of abuse were observed in the positive samples. The method allows for the positive identification of 1200 drugs and metabolites by using accurate mass along with MS/MS confirmation. With the fast, high resolution, accurate mass system, up to 20 product ion scans were collected in about one second allowing for more analytes to be confirmed even with multiple analytes co-eluting. All product ion scans were searched against the library with more than 1250 product ion spectra generated on the QTRAP® System yielding high purity scores.

Key Words: Drug Screening Library

Direct Screening of “Herbal Blends” for Synthetic Cannabinoids by Matrix-Assisted Laser Desorption Ionization-Time of Flight Mass (MALDI-TOF) Spectrometry

Rossella Gottardo^{1,*}, Anna Chiarini², Ilaria Pierpaola Dal Prà², Catia Seri³, Claudia Rimondo³, Giovanni Serpelloni⁴ and Ubaldo Armato².

¹Department of Public Health and Community Medicine, Unit of Forensic Medicine; ²Department of Life and Reproduction Science, Histology and Embryology Section, University of Verona, Verona, Italy; ³National Early Warning System, Addiction Department, ULSS 20, Verona, Italy; ⁴Department of Anti-Drug Policies, Presidency of the Council of Ministers, Italy

Objectives: Since 2004, a number of “herbal blends” containing synthetic cannabinoid analogues have appeared on the market, mainly through the Internet, as a “legal” alternative to cannabis. Because of their recent introduction, the literature regarding these compounds is limited. At present, the few reported methods for “herbal blends” are primarily based on chromatography coupled to mass spectrometry (GC-MS and LC-MS) [1-3]. Although highly selective, sensitive, accurate and quantitative, these methods lack simplicity, rapidity and versatility, which are important features, particularly in the first screening phase. On the other hand, matrix-assisted laser desorption ionization (MALDI)-TOF mass spectrometry (MS) is simplistic in operation and is high throughput, making it attractive for clandestine drug preparation analysis, as reported in the recent literature. The aim of the present study was to develop a MALDI-TOF/ MS application for the rapid screening of synthetic cannabinoids in “herbal blends”.

Materials and Methods: MALDI-TOF mass spectra were recorded with a Voyager De PROTM MALDI-TOF/MS mass spectrometer (Applied Biosystems, Foster City). Mass spectra were analyzed in the range 100-500 m/z by averaging the data from 50 laser shots. The nominal resolution of the instrument was 10,000 (FWHM). The “herbal blend” leaves were finely ground in a mortar and loaded onto the MALDI plate followed by addition of 2 µL of the matrix/surfactant mixture (α -cyano-4-hydroxy-cinnamic acid/cetyltrimethylammonium bromide). After drying, the sample plate was loaded into the ion source for analysis.

Results: In the present work, MALDI-TOF MS was successfully applied for the qualitative determination of synthetic cannabinoids in herbal blends by direct analysis of the leaves. The matrix more suitable for the analyte ionization was a mixture of α -cyano-4-hydroxy-cinnamic acid, typically used in proteomics, and cetyltrimethylammonium bromide (CTAB), which acted as quenching agent to suppress matrix ionization. The method was applied to the direct screening of 30 commercial “herbal blends” for synthetic cannabinoids, previously analyzed by GC-MS and LC-TOF. Among the samples analyzed (n=34), 25 contained synthetic cannabinoids (namely JWH-018, JWH-073, JWH-081, JWH-250, JWH-210, JWH-019, AM-694). The analytical compounds detected perfectly matched up with previous results obtained with GC-MS and LC-MS on the same samples.

Conclusions: We present a method for high-throughput synthetic cannabinoids analysis in commercial “herbal blends” preparations. Although only qualitative, the accurate mass measurement may be adequate to presumptively identify the compounds, while lacking reference standards, with further confirmation available through fragmentation analysis.

References:

- [1] S. Hudson, J. Ramsey, L.King, S. Timbers, S. Maynard, P.I .Dargan, D.M. Wood, *J. Anal. Toxicol.* 34 : 252-260 (2010).
- [2] N. Uchiyama, R. Kikura-Hanajiri, J. Ogata, Y. Goda, *Forensic Sci. Int.* 198: 31-38 (2010).
- [3] D. Zuba, B. Byrska, M. Maciow, *Anal. Bioanal. Chem.* 400: 119-126 (2011).

Key Words: Herbal Blend, Synthetic Cannabinoids, MALDI-TOF

P043

A Rapid Sample Preparation Procedure Utilizing Hybrid Quadrupole Linear Ion Trap Mass Spectrometry Detection as an Analytical strategy for Controlled Drugs in Blood and Application to Forensic Cases in Ireland

Geraldine Dowling*, Eleanor Dixon, Alan Murphy and Liam Regan

The State Laboratory, Backweston Laboratory Complex, Young's Cross, Celbridge, Co. Kildare, Ireland

Objectives: To show the application of a rapid quantitative confirmatory drug testing method in post-mortem blood in forensic testing and to show the prevalence of the targeted drugs in Ireland. The analytical strategy utilises Evolute CX solid phase extraction cartridges with quantification by hybrid quadrupole linear ion trap LC-MS/MS. Controlled drugs under investigation include morphine, codeine, dihydrocodeine, 6-monoacetylmorphine, methadone, levamisole, phenethylamine, cocaine, benzoylecgonine, cocaethylene, buprenorphine, lignocaine, amphetamine, methamphetamine, benzylpiperazine, pseudoephedrine, ketamine, 3,4-methylenedioxyamphetamine, 3,4 methylenedioxymethamphetamine, butylone, flephedrone, methylenedioxypropylone, mephedrone, methylone and methedrone.

Methods: Blood (100-500 μ L) samples were passed through Evolute CXTM mixed mode solid phase extraction cartridges and the sample aliquots were analysed by hybrid triple quadrupole linear ion trap (QTRAP) mass spectrometry with a runtime of 12.5 min. Multiple reaction monitoring (MRM) as survey scan and an enhanced product ion (EPI) scan as dependent scan were performed in an information-dependent acquisition (IDA) experiment. Finally, drug identification and confirmation was carried out by library search with a developed inhouse MS/MS library based on EPI spectra at a collision energy spread of 35 ± 15 eV in positive mode and MRM ratios. The method was validated in blood, according to the criteria defined in Commission Decision 2002/657/EC. At least two MRM transitions for each substance were monitored in addition to EPI spectra and deuterated analogues of analytes were used as internal standards for quantitation where possible. The validation parameters of linearity, precision, recovery, specificity, decision limit (CC₁) and detection capability (CC₂) were determined. The measurement of uncertainty of the method was also determined.

Results: The method was validated in human blood, according to the criteria defined in Commission Decision 2002/657/EC with minor modifications. CC₁ values ranged from 0.01- 0.06 μ g mL⁻¹ and CC₂ values ranged between 0.01- 0.1 μ g mL⁻¹ for the range of compounds tested. The measurement uncertainty of the method ranged between 18-53%. The linear range of the method was between 0 – 2 μ g mL⁻¹.

Conclusion: A rapid method for the determination of the above compounds has been developed and validated. The method is in routine use for Coroner's investigations in Ireland and the applicability of the method has shown good correlation of results when compared with previously developed GC-MS methods used to analyze the same samples and with International Proficiency Testing Scheme samples.

Key Words: Validation, Blood, Hybrid Mass Spectrometry

P044

Evaluation of Supported Liquid Extraction (SLE) for the Determination of Cannabis and Synthetic Cannabinoid Compounds in Blood

Geraldine Dowling^{1,*}, Lee Williams², Rhys Jones² and Liam Regan¹

¹The State Laboratory, Backweston Laboratory Complex, Young's Cross, Celbridge, Co. Kildare, Ireland; ² Biotage GB Limited, IST House, Distribution Way, Dyffryn Business Park, Ystrad Mynach, Hengoed CF82 7TS, United Kingdom

Objectives: To show a rapid confirmatory drug testing strategy in blood using Isolute SLE + for CP47,497; JWH250; JWH019; CP47,497-C8; HU210; JWH018; JWH200; JWH073; delta-9-tetrahydrocannabinol (THC); 11-nor-9-carboxy THC (THC-COOH); 11-hydroxy THC (THC-OH) and THC-COOH Glucuronide.

Method and Results: Cannabis and synthetic cannabinoid extraction efficiencies were optimised on Isolute SLE+ sorbent technology following the application of buffers to provide effective pH control, ion pairing reagents and water immiscible extraction solvents (hexane, methyl tert-butyl ether, dichloromethane, and EtAc) and the sample aliquots were analysed by hybrid triple quadrupole linear ion trap (QTRAP) mass spectrometry with a runtime of 14 min. Multiple reaction monitoring (MRM) was used as survey scan and an enhanced product ion (EPI) scan as dependent scans were performed in an information-dependent acquisition (IDA) experiment using an Applied Biosystems 5500 QTRAP in two separate injections in positive and negative modes. Finally, drug identification and confirmation was carried out by library search with a developed inhouse MS/MS library based on EPI spectra at a collision energy spread of 50±15 eV. The method was validated in blood, according to the criteria defined in Commission Decision 2002/657/EC. At least two MRM transitions for each substance were monitored in addition to EPI spectra and deuterated analogues of analytes were used as internal standards for quantitation where possible as limited internal standards are available at present. The validation parameters of linearity, precision, recovery, specificity, decision limit (CC_β) and detection capability (CC_α) were determined. The measurement of uncertainty of the method was also determined.

Conclusion: The data in the poster highlights a simple extraction protocol and detection protocol for the simultaneous determination of cannabis and synthetic cannabinoids in blood.

Key Words: Blood, Hybrid Mass Spectrometry, Synthetic Cannabinoids, Cannabis, Supported Liquid Extraction

Analytical Reference Standards: Synthesis and Characterization of \pm -threo-Ritalinic Acid-D₁₀ Hydrochloride

Elizabeth Marek*, Huahua Jian, Uma Sreenivasan, and Isil Dilek
Cerilliant Corporation, Round Rock, Texas, USA

Introduction: Methylphenidate, most commonly known by the Novartis trade name Ritalin, is used to treat attention-deficit hyperactivity disorder, postural orthostatic tachycardia syndrome, and narcolepsy. Methylphenidate was originally sold as a mixture of diastereomers, although it has been shown that the majority of the activity is attributed to the \pm -threo isomer. More recent products such as Focalin® contain only the active \pm -threo isomer. While analytical reference standards of the diastereomeric mixture of methylphenidate and its metabolites are available, standards containing only the active isomer are now desirable to reflect the current directive of using only the active isomer in drug preparations. Therefore it is also desirable to synthesize labeled derivatives of the active isomers of methylphenidate and its metabolites for use as analytical reference standards.

Objectives: To synthesize and fully characterize deuterium labeled \pm -threo-ritalinic acid-D₁₀ HCl, an important metabolite and synthetic precursor of methylphenidate, for use as an analytical reference standard. To determine the feasibility of developing an analogous analytical reference standard for \pm -threo-methylphenidate-D₁₀.

Materials and Methods: \pm -threo-Ritalinic acid-D₁₀ HCl was synthesized in seven steps from pyridine-D₅. The identity of the compound was established through NMR and mass spectrometry. The chemical purity was established through HPLC/UV, Karl Fisher, GC/FID Headspace and ROI. LC-MS/MS studies were performed on this compound to evaluate isotopic purity, deuterium distribution, fragmentation patterns and suitability for use as an internal standard. ¹³C and 2D NMR will be used to determine the location of the deuteriums on the molecule.

Results: During the synthesis of \pm -threo-ritalinic acid-D₁₀ HCl, the crucial reduction of a pyridine moiety to the fully deuterated piperidine proceeded in good yield but LC/MS SIM indicated that the product contained a mixture of 50% D₁₀, 30% D₉ and 10% D₈-D₄. The presence of the D₃-D₀ isomers were not detected. This deuterium ratio was carried through to the final product. Further manipulation of the final product did not result in a change of the distribution of the labeling in the molecule. HPLC analysis indicated a purity of 99% with isotopic purity ratio D₀/D₁₀ = 0% by LC/MS-SIM. Because practical ion monitoring is based on the ratio of D₀/D₁₀, the standard was found to be suitable for use as an internal standard in LC-MS/MS analysis of ritalinic acid and related compounds.

Conclusions: \pm -threo-Ritalinic acid-D₁₀ HCl was synthesized in good yield, sufficient ratio of D₀/D₁₀, and 99% purity making it an extremely useful internal standard for the quantitation of ritalinic acid. Further synthetic work aimed at enriching the deuterium content in the molecule will be completed in order to develop an analytical reference standard of the analogous \pm -threo-methylphenidate-D₁₀.

Key Words: Analytical Reference Materials, Ritalinic Acid, Methylphenidate

Method Development for Enantiomer Separation of Minor Metabolites from Gamma-Hydroxybutyrate using Liquid Chromatography Mass Spectrometry

Kimberly Kaplan^{*,1}, Roman Aranda, IV¹, Lindsey R. Crawley¹, Mark L. Miller¹, Madeline A. Montgomery², and Marc A. LeBeau².

¹Counterterrorism and Forensic Science Research Unit; ²Chemistry Unit, U.S. Federal Bureau of Investigation, Laboratory Division, Quantico, VA, USA

Objectives: Effective protocols for identifying exogenous gamma-hydroxybutyrate (GHB) are limited due to both the endogenous nature of GHB and rapid metabolism of exogenous GHB. Enantiomers of 2-hydroxyglutaric acid (2-HGA) and 3,4-dihydroxy-butyric acid (3,4-DBA) are minor metabolites in the GHB metabolic pathway. Following GHB ingestion, it is possible some urinary enantiomeric metabolite ratios will change. The overall objective of this work is to determine if there are significant changes in the enantiomer metabolite concentrations after GHB ingestion for application to forensic analyses. The first step is to develop the analytical platform for separation of enantiomer metabolite standards.

Materials and Methods: Enantiomer standards D- and L-3,4-DBA sodium salt and L-2-HGA disodium salt were synthesized by Ricerca (Concord, OH). D-2-HGA disodium salt and diacetyl-L-tartaric anhydride (DATAN) were purchased from Sigma-Aldrich. Standards were derivatized using DATAN following a method reported by Struys et al. (2004). Experimental variables such as column type, solvent composition, gradient, duration and temperature of derivatization were investigated as part of the method development. A Waters Alliance HPLC coupled to a Thermo LTQ MS/MS was used for this work.

Results: Gradients with methanol, water, acetonitrile, and 0.1% formic acid achieved the best separations. Baseline resolution between derivatized D- and L-2-HGA standards were attained (Xterra C18 or Fusion RP) and shoulder resolution was observed between derivatized D- and L-3,4-DBA standards (Fusion RP). 2-HGA and 3,4-DBA enantiomers formed deprotonated ions $[M+DATAN-H]^-$ in negative ionization mode at m/z 363 and 336, respectively. The MS/MS major fragments were $[M-H-DATAN]^-$ at m/z 147 for D- and L-2-HGA and m/z 119 for D- and L-3,4-DBA.

Conclusions: This straightforward approach for separating minor GHB metabolites has potential for forensic applications. Enantiomeric separations are possible with conventional materials and equipment (without a chiral HPLC column) for the analyses of small organic acids.

References:

Struys EA, Jansen EEW, Verhoeven NM, Jakobs C. (2004) *Clinical Chem*;50:1391-5.

Key Words: GHB Metabolites, Enantiomer, LC/MS/MS

Proof of Concept for Analysis of 120+ Drugs in Whole Blood Using LC/MS/MS

Greg Newland^{*1}, Shannon Clarke², Melanie Stauffer², Nadine Koenig², Joann Sell² and Dean Fritch³

¹AB Sciex, Foster City, CA, USA; ²Health Network Laboratories, Allentown, PA, USA; ³Analytical Associates, Miami Shores, FL, USA

Objective: The aim of this work is to detect the presence of both acidic and basic drugs in whole blood using library searching for positive identification.

Methods: Sample preparation consisted of two separate extractions for each sample. The first extraction started with a protein precipitation of 100 μ L of the blood sample with acetonitrile followed by solid phase extraction using a Varian Bond Elute Certify cartridge. The second extraction consisted of a liquid/liquid extraction of another 200 μ L of the blood sample with ammonium sulfate and methylene chloride. The two extracts were then combined and dried before reconstitution into 1 mL of mobile phase. 10 μ L of reconstituted extract was injected into a (2.1mm x 50mm x 5 μ m) Ultra Biphenyl column (Restek) on an AB SCIEX QTRAP[®] 5500 coupled to a Shimadzu HPLC. The A and B mobile phases were 0.1% formic acid/2 mM ammonium acetate/2% acetonitrile in water and 0.1% formic acid/2 mM ammonium acetate/10% water in acetonitrile respectively. The gradient was held at 2% B for 0.5 min, ramped up to 98% B for 10 minutes, held at 98% B for 5 minutes, ramped back to 2% B in 0.1 min and re-equilibrate at 2% B for 2.5 minutes. Total analysis time was 17.5 min from injection to injection and over 120 drugs were analyzed in a single injection. Initially, precursor ions were identified and optimal collision energies were established for each compound by infusing the analyte in mobile phase directly into the mass spectrometer. Analytes were then grouped into panels of 10 – 15 compounds for method validation. Neat standards were first injected to determine retention time and relative sensitivities. Next, standards were spiked in antemortem blood and extracted at a series of concentrations to determine the LOD and percent drug recovery for each analyte. Carryover experiments were also conducted by spiking the drugs at concentrations of up to 10,000 ng/mL followed by blank extracts to determine the highest concentration that could be injected with a following blank with drug at less than the limit of detection. The limit of detection was determined by monitoring a single MRM transition for each compound and Information Dependant Acquisition and Enhanced Product Ion Scans were used to collect full scan Product Ion spectra for all compounds with a peak height greater than 5000 cps. Analyst[®] Reporter software was used to do library searches. Following the establishment of the LOD for each analyte, known positive postmortem samples were analyzed blind to the analyst to determine correlation with reference lab results.

Results: All spiked antemortem blood standards had a purity score greater than 70% when compared to library spectra obtained on the QTRAP[®] 5500. 120 postmortem patient samples were analyzed at an independent reference lab, which used a GC ion trap, with good correlation to the results obtained at Health Network Laboratories using LC/MS/MS.

Conclusions: An LC/MS/MS method was created to detect the presence of over 120 compounds in 300 μ L of whole blood in a single injection. Two extractions were combined into a single sample to increase throughput while not sacrificing sensitivity or robustness of the method. Automated library searching and report generation aided in the ability to make this an assay suitable for a clinical researcher forensic laboratory setting.

Key Words: LC/MS/MS, Blood, Screen

Pyrolysis of Fentanyl: Isolating Markers of Smoking Abuse

Rona K. Nishikawa* and Suzanne C. Bell
West Virginia University, Morgantown, WV, USA

Introduction and Objectives: Thermal degradation of the parent drug or other impurities, such as that which occurs during smoking, may lead to the potential production of toxic pyrolytic products and can increase the risk of overdose. The inhalation of these pyrolytic products can be used as characteristic markers in post mortem toxicological analysis. Such information could be of investigative use, as well as for monitoring and for the identification of toxic effects separate from the parent drug. Recent work in our laboratory demonstrated the utility of analytical pyrolysis for studying smoked drugs of abuse. We now include thermocoupler temperature analysis to better control temperature and pyrolysis products to identify possible markers associated with smoked fentanyl HCl and fentanyl transdermal patches (FTPs).

Materials and Methods: FTPs are easily obtained and are consumed by smoking the gel and/or the whole patch due to the increased bioavailability when inhaled. Predicting markers of smoked drugs of abuse are considered by analyzing the temperature at which various pyrolytic products are produced. Recent literature showed that peak temperature variations produce variable prevalent pyrolytic products that can have different toxicological effects. A phenyl-substituted pyridine is of toxicological interest given the structural similarities to a known neurotoxin were thought to have been observed at lower pyrolysis temperatures.

To determine peak temperatures achieved during the smoking process and the rate of temperature increase, a thermocouple system was used during the volatilization of the gel matrix of a FTP. The equipment was designed to mimic realistic smoking practices involved in the “chasing the dragon” technique, where fentanyl is heated on a foil with a common butane lighter. This allowed for a more accurate temperature simulation to offer a greater insight into the more prevalent pyrolytic products that would be produced in typical usage.

A commercial pyroprobe was interfaced to a GC/MS using a heated transfer line and needle assembly. Pyrolytic temperature profiles were optimized at temperatures determined by the temperature study using a thermocouple system. The pyrolytic interface was configured with an adsorbent trap containing Tenax. This trapping mode was used to pre-concentrate gaseous products during the pyrolysis. Flash heating desorbed the trapped materials into the injector port and onto the column. Pyrolysis was carried out in trap mode under reductive and oxidative conditions, using helium and air, respectively. A RTX-5MS (30 m, 0.25 mm ID, 0.50 μ m) GC column was used.

Results and Conclusion: By thermocoupler temperature analysis of the fentanyl smoking process, a more accurate account of the rate of temperature increase and peak temperature is obtained. This allowed for a closer resemblance of the temperature parameters of the pyroprobe and actual smoking process to determine the prevalent pyrolytic products.

Key Words: Pyrolysis, Markers, GC/MS

Simultaneous Solid Phase Extraction and GC/MS Quantitation of Cocaine, Cocaine Metabolites, Standard and Extended Opiates, and Opiate Metabolites from Whole Blood

Greg Jellick^{*,1}, Michael Frontz¹, J. Rod McCutcheon¹ and Paul Whitter²

¹Bexar County Medical Examiner's Office, San Antonio, TX, USA; ²Biochemical Diagnostics, Edgewood, NY, USA

Objectives: Forensic casework often requires the modern forensic toxicology laboratory to perform drug screens for a multitude of drugs and metabolites. In San Antonio, the analysis of cocaine and opiate drug classes represent a significant portion of our casework. Recognizing the need for detection, efficiency, and sensitivity for these two distinct drug classes, we have developed and validated a solid phase extraction (SPE) method that simultaneously accomplishes these tasks using gas chromatography/mass spectrometry (GC/MS).

Materials and Methods: Historically, our lab has extracted and quantitated cocaine, opiates and associated metabolites simultaneously. This was initially accomplished with a liquid/liquid extraction and later a hydrophobic SPE method. Recently we wanted to also effectively detect and quantify the keto-enol analyte oxymorphone. The following method was developed which employs a protein precipitation step, conversion of enol to keto groups, hydroxylation of keto analytes, cation exchange extraction and subsequent derivatization of applicable compounds with TMS.

Protein precipitation with acetone is performed on 1 mL of whole blood calibrators, controls and case samples. The supernatant is transferred and evaporated to near-dryness. The subsequent samples are acidified with 1% HCl then treated with a 10% w/v aqueous hydroxylamine solution. The samples are then allowed to incubate at room temperature after which 5 mL of deionized water is added to each. The samples are extracted with SPE columns (GV-65, Biochemical Diagnostics) in accordance with the manufacturer's instructions. The eluents are dried under an air stream, derivatized with BSTFA-TMS and analyzed by GC/MS with selective ion monitoring.

Results: The above procedure has been in use in our lab for the last year and a half and is currently used to detect and quantify the following drugs: cocaine, benzoylecgonine, cocaethylene, morphine, codeine, 6-monoacetylmorphine, hydrocodone, hydromorphone, oxycodone, and oxymorphone. The last four compounds exhibit the keto group targeted for hydroxylation and subsequent TMS derivatization. While some attain lower, the LOD for most drugs is 10 ng/mL. Calibration curves are prepared at 20-500 ng/mL. The procedure has been performed on postmortem and antemortem blood, urine, bile, vitreous humor, and muscle.

Table 1: Statistical Summary for Selected Analytes

Drug	% Bias	% CV	LOQ (ng/mL)	Linear Range (ng/mL)
Cocaine	-0.12 to -10.10	0.82 to 3.59	1	1-1000
Morphine	+4.00 to -15.35	0.99 to 4.38	20	20-500
Hydrocodone	-6.23 to -11.76	0.49 to 5.75	20	20-1000
Oxymorphone	-0.29 to -13.43	1.06 to 6.62	10	10-1000

Conclusion: In conclusion, what might have been conventionally accomplished in two separate extractions is accomplished here in one. This method has also improved our ability to detect cocaine/opiate drugs and metabolites including oxymorphone at low levels.

Key Words: Keto Analytes, Hydroxylamine, SPE

P050

A Simplified Approach to the Extraction of Amphetamines from Urine Using Supported Liquid Extraction Prior to UPLC-MS/MS Analysis

Rhys Jones*, Lee Williams, Steve Jordan, Gavin Jones.
Biotage GB Limited, Dyffryn Business Park, Cardiff, CF82 7TS, UK

Introduction: Amphetamines are commonly abused psychoactive stimulants, thus, their detection is required in workplace drug testing and forensic investigations of road traffic accidents. Immunoassay cross-reactivity with a number of sympathomimetic drugs requires a specific chromatographic confirmation. We demonstrate a rapid and reliable supported liquid extraction (SLE) sample preparation for ephedrine, amphetamine, MDA, MDMA, methamphetamine and MDEA from urine. In this case, analytes were identified after extraction by UPLC-MS/MS.

Methods: SLE was performed on blank human urine (100 μ L in fixed well plate format) spiked with amphetamines at concentrations from 0.5-50 ng/mL. Various pre-treatment protocols and extraction solvents (methyl tert-butyl ether (MTBE), dichloromethane (DCM), 95/5 DCM/isopropanol and ethyl acetate) were investigated. Extracts were evaporated to dryness, reconstituted in mobile phase and injected onto a Waters Acquity UPLC coupled to a Quattro Premier XE triple quadrupole mass spectrometer. An Acquity UPLC BEH C18 column (1.7 μ , 100 x 2.1 mm id) held at 40 °C with an isocratic mobile phase of 80/20 0.1% formic acid in water and 0.1% formic acid in methanol at 0.43 mL/min was used for chromatographic separation. Positive electrospray ionization in MRM mode was utilized. To demonstrate the applicability of SLE, one ion transition was monitored for each analyte: ephedrine 166.1>133.0; amphetamine 136.0>118.9; methamphetamine 150>90.9; MDA 180.1>105.0; MDMA 194.1>163.0 and MDEA 208.2>163.0.

Results: Pre-treatment protocols with 0.5M NH₄OH showed consistently higher analyte recoveries than 100mM NH₄OAc and H₂O pre-treatments for all extraction solvents. Optimum method performance was observed pre-treating urine with 0.5M NH₄OH in combination DCM as the extraction solvent. Recoveries of greater than 85% and corresponding RSDs of less than 10% were obtained at all concentration levels. Limits of detection based on signal to noise experiments with 100- μ L urine were approximately 500 pg/mL for all analytes. To increase the sensitivity of the assay it was possible to scale up the extraction procedure using larger matrix volumes (500 μ L) in combination with larger column formats. No internal standards were used during method development and these data are not intended to demonstrate a validated analytical method.

Conclusion:

We present a simplified approach for extraction of various amphetamines demonstrating reproducible recoveries >85% and limits of detection of 500 pg/mL from 100 μ L urine in a 96 well assay. Method scale-up to accommodate larger specimen volume is possible to attain lower limits of detection.

Key Words: Supported Liquid Extraction, Amphetamines, Sample Preparation

P051

A Novel Approach to the Simultaneous Extraction of 11-nor-9-carboxy- Δ^9 -THC (THCCOOH) and THCCOOH-Glucuronide from Urine using Supported Liquid Extraction prior to UPLC-MS/MS Analysis

Rhys Jones, Lee Williams*, Adam Senior, Helen Lodder, Steve Jordan, Gary Dowthwaite, Gavin Jones
Biotage GB Limited, Dyffryn Business Park, Cardiff, CF82 7TS, UK

Introduction: Naturally occurring cannabinoids bind to receptors in the brain and cause sensations of relaxation and calm. Widespread, illegal use of cannabis led to the necessity for rapid and reliable methods for the analysis and quantification of the THC phase I metabolite, THCCOOH, in urine. Many methods involve hydrolysis of urine to convert phase II THCCOOH–glucuronide metabolite to THCCOOH prior to confirmation and subsequent quantification. We demonstrate a rapid and reliable supported liquid extraction (SLE) sample preparation for simultaneous extraction of THCCOOH and its glucuronide metabolite (THCCOOH-glucuronide) from urine. In this case, analytes were identified after extraction by UPLC-MS/MS.

Methods: SLE was performed on blank human urine (100 μ L in fixed well plate format) and blank urine fortified with THCCOOH and THCCOOH-glucuronide at various concentrations from 2-80 ng/mL. Two sample pre-treatments were tested: 1) an acidic pH pre-treatment with 1% formic acid; 2) and dilution of the urine (1:1) with the ion-pairing reagent dibutylammonium acetate. Extraction was subsequently achieved with ethyl acetate (1 mL). All samples were analyzed on a Waters Acquity UPLC coupled to a Quattro Premier XE triple quadrupole mass spectrometer. Adequate resolution was achieved on an Acquity UPLC BEH C18 column (1.7 μ m, 100 x 2.1 mm) held at 35°C with an isocratic mobile phase of 20/80 0.1% formic acid aqueous and 0.1% formic acid/methanol at 0.4 mL/min. Positive electrospray ionization in MRM mode was utilized. To demonstrate the applicability of SLE, one ion transition was monitored for each analyte, THCCOOH 345.1>327.2 and THCCOOH-glucuronide 519.1>343.1.

Results: Under acidic pH conditions, considerable interference in the MRM transition for THCCOOH-glucuronide was observed. Our solution was to employ an ion-pairing reagent to neutralize the carboxy moiety of THCCOOH to enable extraction at a pH removing matrix interference. Analyte recoveries of greater than 85% and corresponding RSDs of less than 10% were obtained at various concentrations. Limits of detection based on signal to noise experiments with 100- μ L urine were approximately 2 ng/mL for THCCOOH and 40 ng/mL for THCCOOH-glucuronide. To increase the sensitivity of the assay it was possible to scale up the extraction procedure using larger matrix volumes (500 μ L) in combination with larger column formats. No internal standards were used during method development and these data are not intended to demonstrate a validated analytical method.

Conclusion: We present a simplified approach for extraction of THCCOOH and THCCOOH-glucuronide demonstrating reproducible recoveries >85% and limits of detection of 2 and 40 ng/mL, respectively, from 100 μ L urine in a 96 well assay. Method scale-up to accommodate larger specimen volume is possible to attain lower limits of detection.

Key Words: Supported Liquid Extraction, THCCOOH, Sample Preparation

P052

Extraction of Opioids from Urine Using Supported Liquid Extraction Prior to UPLC-MS/MS Analysis

Rhys Jones*, Lee Williams, Steve Jordan, Gavin Jones
Biotage GB Limited, Dyffryn Business Park, Cardiff, CF82 7TS, UK

Introduction: Opioids provide important sedative and pain relieving effects; however, currently prescription opioids also are highly abused. Analytical methods are needed for the sensitive and specific confirmation of opioids. We demonstrate a rapid and reliable supported liquid extraction (SLE) sample preparation for hydromorphone, morphine, oxycodone, hydrocodone, dihydrocodeine, oxycodone and 6-acetyl morphine (6AM) in urine. In this case, analytes were identified after extraction by UPLC-MS/MS.

Methods: SLE was performed on hydrolyzed and unhydrolyzed human urine (100 μ L in fixed well plate format), spiked with opioid reference standards at various concentrations from 5-50 ng/mL. Various pre-treatment protocols were investigated combined with multiple extraction solvents, methyl tert-butyl ether (MTBE), dichloromethane (DCM), 95/5 DCM/isopropanol and ethyl acetate. Extracts were evaporated to dryness, reconstituted in mobile phase and injected onto a Waters Acquity UPLC coupled to a Quattro Premier XE triple quadrupole mass spectrometer. An Acquity UPLC BEH C18 column (1.7 μ m, 100 x 2.1 mm id) held at 40 °C with an isocratic mobile phase of 80/20 0.1% formic acid in water and 0.1% formic acid in methanol at 0.43 mL/min was used for chromatographic separation. Positive electrospray ionization in MRM mode was utilized. To demonstrate the applicability of SLE, one ion transition was monitored for each analyte: hydromorphone 286.2>185.1; morphine 286.2>201.0; oxycodone 302.2>198.1; hydrocodone 300.2>199.1; dihydrocodeine 302.2>199.1; oxycodone 316.2>241.2; 6AM 328.2>165.1).

Results: Pre-treatment protocols for unhydrolyzed urine with 0.5M NH₄OH showed consistently higher analyte recoveries than 100mM NH₄OAc and H₂O pre-treatments with a variety of extraction solvents. Extraction efficiencies from hydrolyzed urine demonstrated that a variety of pre-treatment and extraction solvent combinations resulted in recoveries greater than 70%. Limits of detection based on signal to noise experiments with 100- μ L urine were approximately 1-5 ng/mL for all analytes. To increase the sensitivity of the assay it was possible to scale up the extraction procedure using larger matrix volumes (500 μ L) in combination with larger column formats. No internal standards were used during method development and these data are not intended to demonstrate a validated analytical method.

Conclusion: We present a simplified approach for extraction of various opioids demonstrating reproducible recoveries >70% and limits of detection of 1-5 ng/mL from 100 μ L hydrolyzed urine in a 96 well assay. Method scale-up to accommodate larger specimen volume is possible to attain lower limits of detection.

Key Words: Supported Liquid Extraction, Opiates, Sample Preparation

Reduction of Lorazepam to Delorazepam During Treatment of Urine Specimens with β -Glucuronidase Enzyme

Shanlin Fu* and John Lewis

Centre for Forensic Science, University of Technology Sydney (UTS), Broadway, NSW, 2007 Australia

Objectives: We previously found that oxazepam, either present in patient urine (largely as its glucuronide) or spiked to blank urine by using a reference standard, could be reduced to nordiazepam (desmethyldiazepam) during treatment of urine specimens with commercial β -glucuronidase enzymes from *Escherichia coli*, *Helix pomatia*, and *Patella vulgata*. Formation of the nordiazepam artefact was positively correlated with incubation temperature, incubation time, oxazepam concentration and enzyme concentration. We also found that temazepam, either present in patient urine (largely as its glucuronide) or spiked to blank urine by using a reference standard, could be reduced to diazepam under similar conditions. We now wish to report that enzyme treatment of urine can lead to artefact formation of delorazepam from lorazepam, another benzodiazepine having close structure similarity with oxazepam and temazepam. All of these benzodiazepines have a hydroxyl group at the C3 position in their structure.

Methods: Urine specimens containing free lorazepam were prepared by adding lorazepam reference material to blank urines at 30 $\mu\text{g/mL}$. Urine specimens from patients prescribed lorazepam were supplied by a toxicology laboratory after sample de-identification. These urine samples were incubated with *H. pomatia* β -glucuronidase enzyme (1500 units/mL) at 50°C for 18h. After liquid-liquid extraction with dichloromethane/isopropanol (9:1) at alkaline pH, the extract was analyzed by liquid chromatography – mass spectrometry (LC–MS) in both scan and product ion scan mode. LC separation was achieved on a C18 column and the eluent was monitored on a triple quadrupole MS instrument operated in positive electrospray ionization mode.

Results: Incubation of β -glucuronidase with lorazepam in blank urine resulted in formation of delorazepam (chlordesmethylidiazepam) artefact. This artefact formation was not observed in the corresponding controls from which enzymes were not present while all other parameters such as incubation time, incubation temperature, and pH condition were matched. Identity of the artefact was elucidated based on careful study of the MS/MS spectra acquired in product ion scan mode. The yield of the artefact was not quantified due to lack of a commercial delorazepam reference standard. Delorazepam was not found from any of the patient urine specimens sourced ($n = 4$) following enzymatic hydrolysis. This may be partly explained by the low concentration of lorazepam present in these samples (ranged 1–3 $\mu\text{g/mL}$).

Conclusions: The findings of our studies show that detection of delorazepam in biological samples following enzyme treatment should be interpreted with care, especially in cases of lorazepam overdose or abuse where urinary lorazepam concentrations might be high.

Key Words: β -Glucuronidase, Lorazepam, Delorazepam

Liquid Handling of Whole Blood in a Fully Automated Sample Preparation Setup

David Wederkinck Andersen*, Brian Schou Rasmussen, Kristian Linnet
Section of Forensic Chemistry, University of Copenhagen, Copenhagen, Denmark

Objective: A fully automated sample preparation procedure including automated pipetting of whole blood from postmortem and living subjects was developed and used in routine analysis. The robotic platform included a balance to ensure a precise and accurate determination of transferred sample mass. All mass measurements, calculations, evaluations and data handling were automated to maintain a fully automated system. The information presented includes data from routine analysis, and demonstrates the reliability of a fully automated offline sample preparation.

Materials and Methods: Sample preparation was performed on a Tecan Evo Freedom 200 platform (Tecan Group Ltd., Switzerland) equipped with a robotic manipulator arm, a liquid handling arm using 1000 μ L conductive disposable tips, and several third party add-ons including a Mettler Toledo XP203S balance (Mettler-Toledo Inc., Columbus, OH, USA) modified with a 96 well plate carrier and a custom made acrylic glass draft shield. Blood samples were transferred from standard test tubes to a 96 well plate placed on the balance. The target weight of the transferred sample was set to 210 mg and the sample was pipetted up to 3 times, if the mass of a transferred sample was below a set threshold of 150 mg.

Results: A special layout of the robotic worktable and the work path of the liquid handling arm were designed and optimized to eliminate any possibility of cross contamination. The spread in the transferred sampled mass did not influence the CV of the analysis, since the concentrations of analytes were calculated with the correction of this mass. Thus, all transferred masses above 150 mg were accepted. Additional pipetting steps were introduced to ensure a more narrow distribution of transferred sample masses. Most samples during routine analysis (74.3%, 811 of 1092) were within the desired target weight ($\pm 10\%$, 189 mg to 231 mg). Only 0.5% (5 of 1092) of the samples could not be handled by the automated system and were either homogenized or diluted. Pooled blank blood used for QC and calibration samples could be pipetted and 96.9% (1190 of 1228) were within the desired target weight ($\pm 10\%$, 189 mg to 231 mg).

Conclusion: The setup was able to handle pipetting whole blood of varying viscosities, even postmortem blood. The introduction of additional pipetting steps reduces the number of samples sent for subsequent sample preparation without a noteworthy increase in time consumption. The procedure demonstrates an ideal platform for automatic blood pipetting in different sample preparation techniques e.g. SPE and protein precipitation.

Key Words: Fully Automated Sample Preparation, Whole Blood, Liquid Handling

Sensitive Determination of Amatoxins Using UPLC-MS-MS

Akira Ishii^{1*}, Mina Nomura¹, Yudai Suzuki¹, Rina Kaneko¹, Tadashi Ogawa², Hideki Hattori², and Hiroshi Seno²

¹Department of Legal Medicine and Bioethics, Nagoya University Graduate School of Medicine, Nagoya, Japan;

²Department of Legal Medicine, Aichi Medical University, Nagakute-cho, Aichi, Japan.

Objectives: Amatoxins, found in mushroom species *Amanita*, *Lepiota* and *Galerina*, frequently cause the most severe mushroom poisoning. These amatoxin compounds, such as α -amanitin and β -amanitin are bicyclic octapeptides. We present a rapid and sensitive determination of α - and β -amanitin, and phalloidin in body fluids using an UPLC-MS-MS system.

Methods: Five hundred μ L unpreserved plasma samples were spiked with α - and β - amanitins, and 2.5 mL of sodium acetate buffer (pH 3.0) and 2 mL of distilled water were added. Samples were applied to a Discovery DSC18 column (SUPELCO), and compounds eluted with 3 mL of methanol. The eluent was evaporated to dryness and reconstituted with 100 μ L of 0.1% formic acid; 10 μ L were injected on the LC-MS system, an ACQUITY UPLC-TQD System (Waters). For separation, an ACQUITY UPLC BEH Shield RP18 column (2.1 x 50 mm, Waters) was used. The elution gradient was 95% A:5% B (solvent A: 0.1% formic acid in distilled water; solvent B: methanol) to 45% A:55% B over 3 min and then to 5% A: 95% B over 1 min. An electrospray ionization interface was used in positive ion mode; ion source and desolvation temperatures were 150 and 450°C, respectively. For MS-MS analysis, the m/z values of the precursor ions were: 919.6, 920.6 and 788.9 for α -, β -amanitin and phalloidin, respectively. Product ions were: 919.6, 920.6 and 616.0, respectively. Other parameters were as follows: cone voltage 50V; collision energy 20V for amanitins, 35V for phalloidin; collision gas Ar.

Results: The highest recoveries were obtained with sodium phosphate buffer pH 3. Baseline separation was attained with the ACQUITY UPLC BEH column. Retention times for α -, β -amanitin and phalloidin were 1.6, 1.75 and 2.5 min, respectively. In our system, appropriate internal standards were not available; thus we quantified the compounds without internal standards. However, absolute calibration curves for both amanitins and phalloidin gave acceptable linearities in the range of 10 and 250 ng/mL without internal standards. Detection limits were about 5 ng/mL for α - and β -amanitins and 1 ng/mL for phalloidin. Intra-day variations (n = 6) were: 11.9, 13.7 and 8.3% (20 ng/mL), and 15.6, 17.4 and 10.3 % (100 ng/mL) for α -amanitin, β -amanitin and phalloidin, respectively; the inter-day variations (n = 6) were: 16.5, 14.6 and 15.6% (20 ng/mL), and 17.2, 17.6 and 15.7% (100 ng/mL), respectively. Matrix effects were as follows: at 20 ng/mL, 8.6% enhancement, 1.1% suppression and 4.5% suppression for α -amanitin, β -amanitin and phalloidin, respectively (n = 5), at 100 ng/mL, 1.4% suppression, 7.6% suppression and 7.7 % enhancement, respectively.

Conclusions: The present method for detection of amanitins in human body fluids is highly sensitive, with all retention times within 4 min.

Key Words: UPLC, Tandem mass spectrometry, Amatoxins

P056

New Tools for the Analysis of Cannabinoids in Blood

Stephan Andreas Baumann*

Agilent Technologies, Santa Clara, CA, USA

Objectives: In the past decade a great deal of research concerning the impact of cannabis use on road safety has been conducted. More specifically, studies on effects of cannabis smoking on driving performance, as well as epidemiological studies, were published. As a result, several countries have adopted driving under the influence of drugs (DUID) legislation, with varying approaches worldwide. While a wide variety of bodily fluids have been used to determine the presence of cannabinoids, blood testing is considered the most reliable indicator of impairment. The objective of this study was to show the advantage of combining new chromatographic techniques such as backflushing and low thermal mass columns to a GC/MS/MS for the robust detection of cannabinoids in blood.

Materials and Methods: Chromatography was performed on an Agilent 7890 GC equipped with a large volume inlet and a low thermal mass (LTM) GC column. A LTM column costs roughly twice the amount of a standard GC/MS column. Therefore a pre-column was used to protect the LTM column from non-volatile contaminants. A pressure control tee connected the pre-column to the LTM column. This permits backflushing. During the analytical run the pre-column was in backflush mode with a constant pressure of 1 psi. The inlet pressure pulse was used to override the backflush mode for the initial 0.75 min. This was enough time to transfer the target compounds to the head of the LTM column. This system was coupled to a 7000B triple-quadrupole mass spectrometer run in electron impact (EI) mode. The incorporation of multiple reaction monitoring (MRM) technology increased the method's specificity by removing isobaric interferences that did not have the same precursor to product ion transition as the target compounds.

Results: The linear dynamic range was 0.1 to 50 ng/mL for Δ^9 -tetrahydrocannabinol (THC) and 11-hydroxy-THC (11-OH-THC), and 1 to 100 ng/mL for 11-nor-9-carboxy-THC (THCA) in whole blood. Two milliliter aliquots of whole blood stabilized with potassium oxalate and sodium fluoride were taken through Bond Elut Certify II SPE cleanup before derivatization and GC/MS/MS analysis. Pre-column backflushing greatly reduced the late eluting matrix that entered the analytical column and subsequently, the MS source. The LTM GC column focused analytes at the head of the analytical column, yielding improved peak shape and resolution. Finally, the selectivity of the triple quadrupole further reduced matrix interferences. The root mean square (RMS) signal-to-noise for THC and 11-OH-THC at 0.1 ng/mL was 175:1 and 46:1, respectively, while signal-to-noise for THCA at 1 ng/mL was 39:1. Final run time was 6 min, with a cycle time of 8 min due to efficient LTM column cooling.

Conclusion: We displayed the advantages of applying backflushing, LTM columns, and a GC/MS/MS run in electron impact mode for the robust detection of cannabinoids in blood at concentrations typically considered chromatographically challenging.

Key Words: Cannabinoids, Blood, Mass Spectrometry

Development of an Analytical Method for the Simultaneous Detection of Abused Drugs, Their Metabolites and Common Adulterants in Blood by Precipitation and UPLC/MS/MS

Luz A. Silva-Torres^{1,2,*}, Bianca Torres-Hernández², Jeanette Janer-Figueroa¹, Margarita Meléndez-Negrón¹, María S. Conté-Miller¹ and Diógenes Herreño-Sáenz²

¹Puerto Rico Institute of Forensic Science, Puerto Rico; ²University of Puerto Rico, Medical Science Campus, Pharmacology and Toxicology Department, Puerto Rico

Introduction: Simultaneous detection of drugs in blood is critical in cases involving poly-drug users to evaluate drug-drug interactions and toxic levels. Street drug preparations may include adulterants like atropine, hydroxyzine, caffeine, papaverine, quinine and others. In this study a selective ultra performance liquid chromatography-mass spectrometry (UPLC-MS/MS) method was developed for the simultaneous determination of common abused drugs, adulterants and their metabolites in blood.

Objectives: Develop a simultaneous detection method for 18 drugs using UPLC/MS/MS technology and a single blood protein precipitation procedure. In addition, optimize the toxicological analysis in poly drug users' cases by reduction of the actual operational costs and increasing the number of drugs detected.

Methods: Drugs were cocaine, codeine, morphine, hydroxyzine, xylazine, alprazolam, propranolol, brompheniramine, diphenylamine, doxepin, methadone, oxycodone, quinine, atropine, 6-monoacetylmorphine, benzoylecgonine, alprazolam and THC. Sample preparation was protein precipitation of 250 uL of blood with cold Acetonitrile (750uL), containing all the internal standards. After drying down and reconstituting with a 1:1 mixture of water and methanol, samples were analyzed. Specific determination of each drug was achieved with retention time similarity to internal standards. Co-eluting compounds were separated by mass spectra. Three MRM transitions, 2 qualifiers and one quantifier, were monitored for each analyte; two transitions were used for each of the deuterated analogues. The instrument conditions were Phase A- 1% Formic Acid; Phase B- Methanol; Weak wash solvent (injector system cleaning) 95% water/5% Acetonitrile; strong 95% Acetonitrile /5%Methanol; Column 100% acetonitrile; target column temperature is 40⁰C; target sample temperature 10⁰C; column ACQUITY UPLC HSS T3, 2.1 x 50 mm, 1.8 μm; flow rate 0.6mL/min, and run time 5 minutes. The Waters Acquity UPLC with TQ detector was employed to analyze 145 postmortem blood samples.

Results: Samples were selected from previously analyzed positive cocaine/benzoylecgonine samples. All samples were analyzed to detect 18 drugs previously mentioned, in a range of 25 to 1,000 ng/mL. The limit of detection (LOD) obtained from this method was 8 ng/mL, and the limit of quantitation (LOQ) 1,000 ng/mL for all compounds, although matrix effect has not yet been fully evaluated. Hydroxyzine was present in 104 samples, lidocaine in 84, diphenhydramine in 51, xylazine in 35, alprazolam in 29, atropine in 25, quinine in 13, brompheniramine in 9, doxepin and morphine in 8, methadone in 7, propranolol in 4, THC in 3 and 6-MAM only in one. Codeine and oxycodone were not found. Some samples contain more than 2 drugs; 7.6% had 2 (cocaine and benzoylecgonine), 17.2% three, 25.5% four, 23.5% five, 13.1% six, 6.9% seven, 2.8% eight and 2.1% nine.

Conclusions: This UPLC/MS/MS method is a suitable technique to analyze 18 abused drugs with a single blood protein precipitation in post mortem cases.

Key Words: Xylazine, UPLC/MS/MS, Hydroxyzine

Development of Rapid LC/MS/MS-Based Methods for Confirmatory Analysis of Opiates and Benzodiazepines

Dwight R. Stoll*¹, Spencer Bonnerup¹, David Christopher Harmes¹, Tomas Liskutin¹, Jonna Berry¹ and Kathryn Fuller²
¹Gustavus Adolphus College, St. Peter, MN, USA; ²Minnesota Bureau of Criminal Apprehension, St. Paul, MN, USA

Objectives: Forensic laboratories strive for the development of high throughput methods, particularly for confirmatory analysis of regulated intoxicants. In this work, we focused on the development of rapid LC/MS/MS methods for the determination of 9 opiates including two glucuronide metabolites, and 16 benzodiazepines, including two amino-metabolites, in blood and urine samples. Currently, forensic laboratories often utilize multiple methods due to the large range of hydrophilicity presented by these groups of compounds (e.g., parent drugs and polar metabolites). Here we aim to analyze both the parent compounds and the important polar metabolites for each drug class in a single analysis (i.e., one method for opiates, and one method for benzodiazepines).

Methods: During method development, we compared retention of the target compounds on two different reversed-phase HPLC stationary phases: a conventional C18 type phase, and a perfluorinated phenyl (PFP) phase. The latter phase exhibited significant cation-exchange behavior for the compounds studied. Furthermore, the PFP column is built upon the increasingly popular core-shell particle morphology which presents significant opportunities to improve the speed of analysis. We found that the PFP column exhibited greater retention than the C18 type phase, but also exhibited different selectivity.

Results: Using a 75 mm x 2.1 mm i.d. PFP column operated at 0.5 mL/min (with 1:1 split to waste) and ammonium formate and acetonitrile mobile phases and conventional HPLC instrumentation, we developed a method that provided excellent resolution of 9 opiates in less than 4 min. We developed a separate method for the benzodiazepines (but with the same PFP column and solvents) and found that all 16 compounds cannot be completely resolved in less than 20 min; however, we developed a gradient elution retention model for these compounds that facilitates the separation with no more than 3 overlapping peaks in an analysis time of 5 min. Validation of these two methods is currently underway for use in casework at the MN BCA laboratory.

Conclusions: Modern core-shell HPLC particle technology provides opportunities to significantly improve the throughput (<5 min analysis time) of confirmatory LC/MS/MS methods for opiates and benzodiazepines using a single column and solvent system, and two distinct methods that involve different gradient elution programs.

Key Words: Opiates, Benzodiazepines, Confirmatory Analysis

Construction of a LC-MS/MS Library for Screening 242 Drugs and Toxic Compounds**Yurong Zhang***, Haiying Ye, Chen Liang, Rong Wang and Chunfang Ni

Shanghai Institute of Forensic Science (Shanghai Key Laboratory of Crime Scene Evidence), Shanghai, China

Objective: Forensic toxicology testing is challenging, since analytes are often unknown, and suspected substances are numerous. Having a library of known ion transitions for comparison during LC-MS/MS screening would aid identification in cases with unknown toxicological histories.

Materials and Methods: Based on our testing experience over years from crime investigation cases in Shanghai, P. R. China, 242 drugs and toxic compounds were chosen as the target substances for this analysis; including antipsychotic drugs (such as benzodiazepines and barbiturates), drugs of abuse (such as opioids, cocaine and amphetamines), insecticides (such as organophosphorus insecticide, carbamate insecticide and synthetic pyrethroids insecticides), herbicides, and rodenticides. Standards were purchased from China National Institutes for Food and Drug Control, Sigma Corporation, Cerilliant Corporation, Shanghai Pesticide Research Institute and prepared in methanol. Standard solutions and extracted samples (blood, urine, gastric content, or water) were injected into a liquid chromatography-electrospray tandem mass spectrometry (LC-MS/MS) system. A method utilizing LC-MS/MS was developed for screening these 242 compounds. Separation was achieved on a C18 column (Waters Xterra[®] MS C₁₈, 3.5 μ m 2.1 \times 150mm) kept at 45°C, with a mobile phase flow-rate of 0.2 mL/min and elution gradient composed of solvent A (2 mM ammonium formate and 0.05 % formic acid in water) and solvent B (2 mM ammonium formate and 0.05 % formic acid in acetonitrile). The runtime was 33 min. The mass spectrometer (Waters Alliance 2695/Quattro Premier XE) was operated in the multiple reaction monitoring (MRM) mode, with 2 transitions per compound.

Results and Conclusion: Based on MRM ratio and retention time, a screening library was constructed, including all 242 compounds. The library is successfully applied to forensic cases. For example, a suspected bottle from the crime scene was washed with chloroform. After evaporation and reconstitution in initial mobile phase, the sample was injected into a LC-MS/MS system. Based on the standards for qualitative determination (the signal/noise ratio of two daughter ions should be more than 10; the retention time error should be within $\pm 2.5\%$; the intensity ratio of daughter ions should be within the allowed error range ($\pm 20\%$), paraquat was found.

Key Words: Unknown Toxicological Analytes Identification, Screening Library, LC-MS/MS

P060

Identification and Quantification of 28 Drugs and Toxic Compounds in Blood, Urine and Gastric Content using LC-MS/MS

Chen Liang*, Haiying Ye, Yurong Zhang, Rong Wang and Runsheng Zhang
Shanghai Institute of Forensic Science (Shanghai Key Laboratory of Crime Scene Evidence), Shanghai, China

Objectives: A LC-MS/MS method was developed for simultaneously screening 28 drugs and toxic compounds in forensic cases.

Materials and Methods: These compounds were morphine, codeine, cocaine, 3,4-Methylenedioxymethamphetamine (MDMA), pethidine, methadone, dextropropoxyphene, diazepam, flurazepam, nitrazepam, flunitrazepam, clonazepam, estazolam, alprazolam, midazolam, triazolam, methaqualone, barbital, phenobarbital, secobarbital, pholcodine, scopolamine, anisodamine, strychnine, brucine, zolpidem, chlordiazepoxide and fentanyl. Morphine-D3, pethidine-D4, diazepam-D5 and aprobarbital were used as internal standards. 0.5 mL of blood (diluted 1:1 with water) or 1.0 mL of urine sample was purified by solid-phase extraction (Oasis HLB). The SPE cartridge was conditioned before use with 1 mL of methanol and 1 mL of purified water. The washing solution and elution solvent were 1 mL of 5% methanol and 1 mL of methanol, respectively. Gastric content (diluted 1:1 with water) was precipitated with acetonitrile, centrifuged, and supernatant injected. Detection was achieved using a Waters Alliance 2695/Quattro Premier XE LC-MS/MS system equipped with an electron spray ionization (ESI), operated in the multiple reaction monitoring (MRM) mode. The method was validated for accuracy, precision, linearity, and recovery.

Results and Conclusions: The absolute recovery of drugs and toxic compounds in blood was greater than 51% with the lower limit of detection (LOD) in the range of 0.02-20 ng/mL. The absolute recovery of drugs and toxic compounds in urine was greater than 60% with LODs in the range of 0.01-10 ng/mL. The LODs of drugs and toxic compounds in gastric content samples were in the range of 0.05-20 ng/mL. This method was applied to the routine analysis of drugs and toxic compounds in postmortem blood, urine, and gastric content samples. In two case examples, diazepam and estazolam (0.12 and 0.37 µg/mL respectively) in the heart blood of a deceased man was detected, and phenobarbital at a concentration of 0.25 µg/mL was detected in the heart blood of a deceased woman.

Key Words: Drugs and Toxic Compounds, Quantification, LC-MS/MS

Inhibition of 1, 4-butanediol metabolism in human liver *in vitro*

Daniel Lenz, Martin Juebner, Annette Wintermeyer, Justus Beike, Markus A. Rothschild, Herbert Kaefenstein, **Katja Bender***

Institute of Legal Medicine, Medical Faculty, University of Cologne, Melatenguertel 60/62, D-50823 Cologne, Germany

Introduction and Objectives: 1,4-butanediol (1,4-BD) is a pro-drug of gamma-hydroxybutyric acid (GHB). Because it is widely used in industry as a solvent, 1,4-BD is easily available. At present it is not controlled by narcotic law in Germany. As a pro-drug of the central nervous system depressing gamma-hydroxybutyric acid (GHB), 1,4-BD is abused for the same reasons as GHB. Furthermore, co-ingestion with ethanol is very common. The conversion of 1,4-BD to GHB is likely catalyzed by alcohol dehydrogenase (ADH), and potentially by aldehyde dehydrogenase (ALD). The purpose of this study was to investigate the degradation of 1,4-BD in cytosolic supernatant of human liver *in vitro*, and to verify involvement of the suggested enzymes by means of gas chromatography-mass spectrometry (GC-MS).

Methods and Results: 1,4-BD and GHB as well as the internal standards 1,5-pentanediol and GHB-d6 were detected as TMS-derivatives. Linearity for 1,4-BD and GHB was up to 5000 μM . The LOQ was 25 μM for 1,4-BD and 2.5 μM for GHB. The target analyte for the determination of kinetic parameters of 1,4-BD was GHB. The inaccuracy (bias) determined at GHB concentrations of 10, 100, and 500 μM was 16.7 %, -3.6 % and 2.6 %. The inter-day imprecision (relative standard deviation) was 9.9 %, 3.1 % and 2.9 %, respectively. Co-ingestion of 1,4-BD and ethanol (EtOH) may cause complex pharmacokinetic interactions in humans, due to competition for their metabolising enzymes. Therefore, the effect of EtOH on 1,4-BD metabolism by cytosolic human liver enzymes was examined *in vitro*. Furthermore, the influence of acetaldehyde (AL), which might inhibit the second step of 1,4-BD degradation by ALD, was investigated as well. The alcohol dehydrogenase inhibitor fomepizole (4-methylpyrazole, FOM) has been discussed in the literature as an antidote to prevent the formation of GHB in one case of 1,4-BD intoxication. In addition to FOM, we tested pyrazole, disulfiram and cimetidine as other possible inhibitors of the formation of GHB from 1,4-BD catalyzed by human liver enzymes *in vitro*.

Conclusions: Our results show that the conversion of 1,4-BD to GHB can be inhibited competitively by EtOH *in vitro* with an apparent K_i of 0.56 ± 0.05 mM (n=5). This indicates that the co-ingestion of 1,4-BD and EtOH may increase the concentration and effects of 1,4-BD *in vivo*. In contrast to these findings, it is noteworthy that AL accelerated the formation of GHB *in vitro*. All antidotes showed the ability to inhibit the formation of GHB. In comparison, FOM showed the highest inhibitory efficiency. Furthermore, the results confirm strong involvement of ADH in 1,4-BD human hepatic metabolism.

Key Words: 1,4- Butanediol, Gamma-Hydroxybutyric Acid, Aldehyde Dehydrogenase

Sublingual Buprenorphine Pharmacokinetics: Gender Differences

David E. Moody^{*,1}, Wenfang B. Fang¹, Jerdravee Morrison¹ and Elinore McCance-Katz²

¹Center for Human Toxicology, University of Utah, Salt Lake City, UT, USA; ²Department of Psychiatry, The University of California, San Francisco, CA USA

Funded in part by grants R01 DA10100 (DEM), R01 DA13004 (EMK) and K24 DA023359 (EMK) from the National Institute on Drug Abuse

Objectives: Buprenorphine is a partial mu receptor agonist used to treat opioid dependence, as an analgesic, and recently as an off-label treatment for pain management. Gender differences are known to exist in the pharmacokinetics of many drugs. Factors may include variances in body composition, body weight, hormonal status, and use of different co-medications. Recently small but significant gender-dependent differences in cytochrome P450 (CYP) 3A-dependent metabolism have been demonstrated. Since buprenorphine N-dealkylation to norbuprenorphine is primarily performed by CYP3A, we asked whether similar gender-dependent differences are factors in the pharmacokinetics of buprenorphine.

Methods: A retrospective examination was made of control (buprenorphine-only) sessions from a number of drug interaction studies between buprenorphine and antiretrovirals. As a previous retrospective study had shown an effect of cocaine on buprenorphine pharmacokinetics based on comparison of opioid-dependent subjects under buprenorphine treatment with and without cocaine metabolite positive urine tests, this study was restricted to subjects who had a cocaine negative urine test prior to participation in the control session. Twenty such males and eleven females were identified while also taking the same maintenance dose of sublingual buprenorphine/naloxone (16/4 mg). Pharmacokinetic data from participants' initial control sessions were sorted by gender and compared using the two-sample t-test.

Results: Females had significantly higher mean AUC and mean C_{max} (ratios of mean of females to mean of males in parentheses) for buprenorphine (1.39, 1.35), norbuprenorphine (1.65, 1.52) and norbuprenorphine-3-glucuronide (1.53, 1.52). AUCs were then adjusted for dose per body weight, dose per surface area, and dose per lean body weight. Mean AUCs relative to dose per body weight and dose per surface area still had significantly higher AUCs for norbuprenorphine; those for lean body weight, however, were no longer significantly different.

Conclusions: Gender-related differences exist in the pharmacokinetics of buprenorphine. Variations in body composition (as measured by weight, surface area and lean body mass) appear to be major factors in these differences; variations in CYP3A-dependent metabolism may also contribute. This gender difference may prove important in explaining gender-dependent variations in response to buprenorphine and potential risk differences between genders.

Key Words: Buprenorphine Pharmacokinetics, Gender Differences

Distribution of Nalbuphine in Putrid Albino Rat Organs by HPLC-UV**Wagdy Abdelmegeed Soliman***

Toxicological and Drugs Laboratory, Forensic Medicine Authority, Tanta, Egypt

Objectives: Nubain (nalbuphine hydrochloride) is a synthetic narcotic agonist–antagonist analgesic of the phenanthrene series. Quantitative nalbuphine residue estimation in albino rat tissues under putrefaction was performed by high performance liquid chromatography with ultraviolet detection (HPLC-UV). A rat model was used to evaluate nalbuphine concentrations in multiple specimens following different periods of putrefaction to predict findings in human tissues.

Methods: Ten male albino rats (120-130 g) were divided into two groups, each group consisting of five rats. The first group was treated with distilled water only as a control. The second group was treated with nalbuphine at LD50 (297 mg/kg) i.v. Rats were sacrificed after three hours and dissected. Specimens collected included liver, kidney, brain and heart blood in separate mackquarting bottles after being minced and mixed. Specimens were stored in a closed cabinet at room temperature and allowed to putrefy for different intervals (days) to study the effect of putrefaction on the disappearance of nalbuphine. Control group organs were subjected to extraction and isolation procedures immediately after scarification. Nalbuphine was extracted from blood and tissues by liquid–liquid extraction using ammonium sulphate and methylene chloride. Nalbuphine was quantified by HPLC-UV using a C18 column and methanol as mobile phase (2 mL/min) with detection at 254 nm [1]. Nalbuphine metabolites were not evaluated.

Results: Rate of disappearance of nalbuphine in multiple specimens from rats treated with 297 mg/kg nalbuphine is summarized below.

Liver 0.3-5 mg/kg 0.3 mg/kg		Kidney 10-20 mg/kg 0.1/0.2 mg/kg		Brain 0.005-0.17 mg/kg 0.004/0.005 mg/kg		Blood 0.2-10 mg/L 0.1/0.2 mg/L		Specimen Linearity LOD/LOQ
Loss %	Content (mg/g)	Loss %	Content (mg/g)	Loss %	Content (mg/g)	Loss %	Content (mg/L)	Period of putrefaction (days)
			40.4		67.9		8.6	Fresh
30.9	5.5	27.9	29.1	24.3	51.3	20.8	6.8	10
71.7	3.8	68.0	12.9	50.0	33.9	53.5	4.0	20
95.6	1.6	87.3	5.1	76.6	15.9	88.2	1.0	30
100.0	0.2	99.0	0.4	97.0	2.0	95.6	0.4	40
	0.0	100.0	0.0	99.2	0.5	100.0	0.0	50
				100.0	0.0			60

Conclusions: Brain and kidney are the most important matrices of toxicological interest, as they displayed the greatest nalbuphine stability at the post-mortem period of 60 days.

References:

[1] Couper, F.J. et al. Journal of Forensic Sciences (1995) 40:87-90.

Key Words: Nalbuphine, Tissue Distribution, Putrefaction, Stability

P064

The uPA^{+/+}-SCID Chimeric Mouse: a Model for *in vivo* Study of Mibolerone Metabolism

Leen Lootens^{*1}, Annelies De Spaey¹, Koen Deventer¹, Philip Meuleman², Geert Leroux-Roels², Peter Van Eenoo¹
¹DoCoLab and ²CEVAC, Ghent University, Belgium

Objectives: Mibolerone, mentioned on the WADA-prohibited list of banned doping substances, was selected for an *in vivo* excretion study with the chimeric mice. Mibolerone is a 17-methylated steroid with a sterane core and an additional methyl group on the C_{7α} position. Mibolerone is not a new drug, it was first synthesized in the 1960's, but its metabolism is now reinvestigated in an *in vivo* 'humanized' animal model, due to ethical concerns for testing in humans. In the past, this chimeric mouse model was proven to be a good model to perform *in vivo* metabolic studies of anabolic steroids, as data obtained in the chimeric mice were relevant to human metabolism. The chimeric model consists of a transgenic uPA^{+/+}-SCID mouse, transplanted with human hepatocytes. This humanized liver has functional phase I and II metabolizing enzymes, important for steroid metabolism. The aim was to investigate mibolerone metabolism in a chimeric uPA^{+/+}-SCID mouse model with a humanized liver.

Methods: Mibolerone was orally administered to 2 chimeric mice with different human albumin concentrations and to 1 non-chimeric mouse (without transplanted human hepatocytes) as a control. Excretion urine samples were collected before and 24 hours after administration via specially designed metabolic cages for small rodents that separate urine and feces. The steroid compounds present in mouse urine were extracted by a liquid-liquid extraction. Pre- and post-administration mouse urine samples were analysed with a GC/MS scan method and an LC/MS-MS open screening method.

Results: An evaluation of the metabolic pattern of mibolerone was done by comparing chromatograms before and after administration. Besides the parent compound mibolerone, several mono- and dihydroxylated metabolites were detected in the post-administration urines. In total 11 compounds were detected in chimeric and non-chimeric mice of which 5 were exclusively detected in the chimeric mouse urine.

Conclusion: Several metabolites were detected after mibolerone administration in the chimeric mouse urine. These metabolites can be incorporated in analytical methods to screen for mibolerone misuse.

Key Words: Mibolerone, GC/LC-MS, Urinary Metabolism

Acute Administration of MDMA Induces Hepatocellular Damage, Oxidative Stress and Lipoperoxidation in Rat Liver

Steven B. Karch*¹, Stefania Bello², Carmela Fiore², Margherita Neri², Cristoforo Pomara² and Irene Riezzo²

¹P.O. Box 5139, Berkeley, California 94705, USA; ²Department of Forensic Pathology, Faculty of Medicine, University of Foggia, Foggia, Italy

Objectives: Liver toxicity is one of the consequences of ecstasy (MDMA) abuse and hepatocellular damage is reported after MDMA consumption. It is characterized by a wide range of variability in clinical manifestations, ranging from asymptomatic liver injury (as confirmed by altered liver function tests) to life threatening acute hepatic failure. In the last few years, the clinical cases of hepatotoxicity, associated or not with the other adverse effects, were increasingly described in the literature. The evidence to date suggests that there is more than one pattern of MDMA liver damage in which different mechanisms may be involved. Consequences of MDMA administration on liver damage in humans and laboratory animals, along with an overview of mechanisms underlying these hepatotoxic effects will be presented and discussed in this study. MDMA undergoes extensive hepatic metabolism that involves the production of reactive metabolites which form adducts with intracellular nucleophilic sites.

Materials and Methods: The aim of the present study was to obtain evidence for the oxidative stress mechanism involved in ecstasy-induced hepatotoxicity in 50 rats after a single 20 mg/Kg i.p. MDMA dose. Reduced and oxidized glutathione (GSH and GSSG), ascorbic acid, superoxide dismutase, glutathione peroxidase (GPx), glutathione reductase (GR) and malondialdehyde (MDA) were determined in rat liver after 3 and 6 hours after MDMA treatment.

Results: The effect of a single MDMA treatment included decrease of GR and GPx activities and GSH/GSSG ratio with an increase of MDA after 3 h from ecstasy administration. The results of this study clearly show that MDMA impairs the antioxidant cellular defense system and induces oxidative stress and lipid peroxidation in rat liver.

Conclusions: It can be postulated that the metabolism of MDMA results in the formation of highly aggressive compounds, causing depletion of the antioxidant defense and produces irreversible hepatic cellular injury, one cause of liver toxicity associated with MDMA administration.

Key Words: MDMA, Hepatotoxicity, Rat Model

Evaluation of *In Vitro* Metabolic Assay Systems for Common Drugs of Abuse**Kevin J. Schneider*** and Anthony P. DeCaprio

Department of Chemistry and Biochemistry and International Forensic Research Institute, Florida International University, Miami, FL, USA

Introduction and Objectives: A number of *in vitro* assays have been developed by the pharmaceutical industry to model *in vivo* enzymatic metabolism of new drug entities. To date, these approaches have not been applied to drugs of abuse. The present study evaluates and compares the efficacy of five such assay systems to identify metabolic profiles of cocaine, methamphetamine, and morphine. The performance of each *in vitro* system is assessed by examining their ability to generate Phase I and II metabolites and by comparing metabolite profiles with those previously described in the literature.

Methods: The five assays tested in this study were those based on 1) human liver microsomes, 2) human liver cytosol, 3) human liver S9 fraction, 4) horseradish peroxidase, and 5) purified human cytochrome P450 3A4 as the primary biotransformation components. Drugs of abuse were incubated individually with each metabolic system under physiological conditions (pH 7.4 sodium phosphate buffer, 37°C) for 0.5 and 24 h. After incubation, acetonitrile was added to precipitate proteins and terminate metabolism, and samples were centrifuged at $100,000 \times g$ for 30 min at 4°C. The supernatant was recovered and diluted for identification of metabolites on an Agilent 6490 triple quadrupole LC-MS/MS with 1290 Infinity UHPLC, Jet Streaming technology, and electro spray ionization.

Results: Incubations with *in vitro* model metabolism systems were able to elicit the formation of multiple non-enzymatic transformation products in addition to oxidative and P450-mediated metabolites for each drug. Specific differences were apparent in the relative ability of each metabolic system to generate the 89 individual metabolites examined in this study. For example, the cocaine N-demethylation products norcocaine and benzoylecgonine were only detected in systems containing P450 enzymes (*e.g.* human liver microsomes). Additionally, 3- and 4-hydroxycocaine were detected in both the microsome and peroxidase systems while 2-hydroxycocaine was only generated by the peroxidase system. In general, the production of metabolites by each system was consistent with human biotransformation schemes reported in the literature, although some evidence for novel metabolites was obtained. Comparisons between 0.5 and 24 h incubations also revealed specific differences between products that were further metabolized (*e.g.* norcocaine concentration decreased from 0.5 to 24 h time point) and those that were not (*e.g.* ecgonine ethyl ester concentration increased from 0.5 to 24 h).

Conclusion: *In vitro* metabolic assays can be useful in comprehensively mapping the Phase I and II metabolism of drugs of abuse and generating reactive intermediates. Incubation time and enzyme components were found to be important variables for the production of target metabolites. These systems can also be useful as a means of generating metabolic profiles for novel or unknown drugs of abuse.

Key Words: Metabolism, Drugs of Abuse, *In Vitro* Assay

P067

Effects of Ethanol on the Toxicokinetics of Methamphetamine in Rabbits

Yujin Wang*, Yun Zhang, Meili Liu

School of Forensic Medicine, Shanxi Medical University, No.56 Xinjian South Road, Taiyuan 030001, China

Objectives: Methamphetamine (MA) is a strong central nervous system stimulant and abuse may occur through smoking, snorting, injecting or oral administration. In China, MA abuse is often accompanied by recreational consumption of ethanol (EtOH). However, it is unclear whether EtOH changes MA toxicokinetics (absorption, distribution, metabolism, and/or excretion). In the current study, the effects of ethanol (EtOH) on MA toxicokinetics and its metabolite amphetamine (AP) were investigated.

Materials and Methods: A single dose of 15 mg/kg MA hydrochloride was intragastrically administered, either alone (MA group; n=8) or in conjunction with 3 g/kg EtOH (MA+EtOH group; n=8) to rabbits. Physiological saline was intragastrically administered to four rabbits as the placebo-controlled group. Plasma and urine samples were collected and analyzed by gas chromatography/mass spectrometry (GC/MS) for MA and AP. Toxicokinetic parameters of MA and AP were determined using WinNonlin. Vital signs were closely monitored for 3h post-dose.

Results and Conclusion: Our results showed that concomitant intake of EtOH with MA caused a significant increase in the plasma MA absorption constant (K_a) and maximum concentration (C_{max}) compared with the MA only group. The mean MA K_a values increased from $0.679 \pm 0.023/h$ to $0.964 \pm 0.033/h$ ($P<0.05$), and the mean C_{max} from 1.408 ± 0.072 mg/L to 1.676 ± 0.135 mg/L ($P<0.05$), whereas plasma MA T_{max} appeared to significantly decrease from 1.620 ± 0.062 to 1.259 ± 0.033 h ($P<0.05$). In contrast, no significant difference was observed on MA clearance. Furthermore, the plasma AP area under the curve (AUC_{0-30h}) and C_{max} increased from 5.281 ± 0.264 mg/h/L to 13.052 ± 0.956 mg/h/L and from 0.315 ± 0.010 mg/L to 0.423 ± 0.042 mg/L, respectively ($P<0.01$), when EtOH was co-administered with MA. Therefore, co-administration of MA and EtOH caused significant acceleration in MA absorption and subsequent metabolism to AP, yet appeared to have minimal MA elimination effects in rabbits. Taken together, our observations suggest potentially aggravating effects of EtOH consumption on MA toxicokinetics.

Key Words: Methamphetamine, Alcohol, Pharmacokinetics, Drug Interaction

Pharmacokinetic Drug-Drug Interactions of MDMA with Methamphetamine in Brain

Yuki Fuchigami*, Rie Ikeda, Mitsuhiro Wada, Naotaka Kuroda and Kenichiro Nakashima
Graduate School of Biomedical Sciences, Nagasaki University, Nagasaki, Japan

Objectives: Adverse reactions have been documented in methamphetamine (MAMP) and 3,4-methylenedioxymethamphetamine (MDMA) Japanese co-abusers. MDMA and MAMP are sometimes co-abused and seized MDMA tablets often contain MAMP. Therefore evaluation of MDMA and MAMP drug-drug interactions are necessary. In this pharmacokinetic (PK) study drug-drug interactions between MDMA and MAMP in brain were evaluated in rats co-administered MDMA and MAMP.

Methods: A MAB6 microdialysis probe (4-mm, polyethersulfone membrane) was implanted in the left striatum (coordinates: A, +0.6 mm; L, +3.0 mm from bregma; H, -7.0 mm from the skull surface) to rats anesthetized with ethylcarbamate (1.5 g/kg, i.p.). After probe implantation male Wistar rats were administered drugs (i.p.) in the following combinations A) MDMA 12 mg/kg + saline (n=3), B) MDMA 12 mg/kg + MAMP 10 mg/kg (n=4) and C) MAMP 10 mg/kg + saline (n=3). The microdialysis probe was perfused with artificial cerebrospinal fluid (aCSF) at a flow rate of 2.0 μ L/min. Preparation of the brain microdialysate specimens and high pressure liquid chromatography-fluorescence detection conditions to determine MDMA and MAMP were according to our previously published method with minor modification [1].

Results and Conclusions: MDMA and MAMP microdialysate concentrations were monitored until 600 min after drug administration. When MAMP was co-administered, we observed the following MDMA PK parameters (C_{\max} : 1702.1 ± 346.9 ng/mL, AUC_{0-600} : 356.4 ± 67.2 \square g·min/mL and CL: 10.3 ± 1.8 mL/min, n=4) significantly increased compared to that with MDMA alone (C_{\max} : 1067.4 ± 247.6 ng/mL, AUC_{0-600} : 195.0 ± 65.9 \square g·min/mL and CL: 20.0 ± 6.4 mL/min, n=3). Additionally, $T_{1/2}$ and mean residence time (MRT) of MAMP co-administered with MDMA were significantly prolonged compared to those of MAMP alone. Our results support reports of adverse reactions after MDMA and MAMP co-administration.

References:

[1] M. Tomita *et al.*, *Biomed. Chromatogr.*, 21, 1016-1022 (2007).

Key Words: MDMA, Methamphetamine, Pharmacokinetic Drug-Drug Interaction

Effect of Co-Administration of MDMA and Methamphetamine on Dopamine and Serotonin Levels in Rat Brain

Rie Ikeda*, Yuki Fuchigami, Miki Kuzushima, Mitsuhiro Wada, Naotaka Kuroda and Kenichiro Nakashima
Graduate School of Biomedical Sciences, Nagasaki University, Nagasaki, Japan

Objectives: 3,4-Methylenedioxymethamphetamine (MDMA) is a psychoactive stimulant abused by young people as a recreational drug. Other compounds, either deliberately added or present as by-products, are often found in MDMA tablets and can unexpectedly interact with each other. However, available information for pharmacodynamic (PD) interaction between the drugs isn't sufficient. The aim of this study was to evaluate the PD effects of interactions caused by concomitants in MDMA tablets on extracellular dopamine (DP) and serotonin (5-HT) by microdialysis in the striatum of rats.

Methods: Male Wistar rats were divided into three groups and i.p. administered drugs after implanting probe as follows i) MDMA 12 mg/kg + saline, ii) MDMA 12 mg/kg + methamphetamine (MP) 10 mg/kg, and iii) MP 10 mg/kg + saline. A MAB6 microdialysis probe (4-mm, polyethersulfone membrane) was implanted in the left striatum (coordinates: A, +0.6 mm; L, +3.0 mm from bregma; H, -0.7 mm from the skull surface) to rats anesthetized with ethylcarbamate (1.5 g/kg, i.p.). The probe was perfused with artificial cerebrospinal fluid (aCSF) at a flow rate of 2.0 μ l/min. HPLC-ECD conditions: Column, EICOM PP-ODS (30 \times 4.6 mm, i.d., 2 μ m); Mobile phase, 1% methanol in 0.1 M phosphate buffer (pH 6.0) containing 50 mg/L EDTA-2Na and 500 mg/L sodium 1-decansulfonate; Column temperature, 20°C; Applied potential, +400 mV; Flow rate, 0.5 mL/min.

Results and Conclusions: The concentration of DA and 5-HT were monitored until 600 minutes after administration of the drugs to the rats. The AUC₀₋₆₀₀ ($\times 10^3$ nM \cdot min) of DA for MDMA, MP, and MDMA+MP groups were 31.5 ± 21.1 , 182.0 ± 31.1 and 243.4 ± 65.7 , respectively. Remarkable contribution of MP for increasing DA level was found. The DA level for MDMA+MP corresponded to the sum of DA levels for MDMA and MP groups. On the other hand, AUC₀₋₆₀₀ ($\times 10^3$ nM \cdot min) of 5-HT for MDMA, MP, and MDMA+MP groups were 3.5 ± 2.0 , 2.8 ± 1.1 and 11.4 ± 8.4 , respectively. The contribution of MDMA and MP for increasing of 5-HT was comparable. These results serve as a warning of the risk of administration of MDMA tablets containing MP for human health.

Key Words: MDMA, Methamphetamine, Pharmacodynamic Drug-Drug Interaction

P070

Development of New Polyclonal Antibodies for the Screening of JWH Synthetic Cannabinoids and Metabolites

Benchikh, ME* Lowry, P, Innocenzi, P, Orsulak, P, McConnell, RI, and Fitzgerald, SP
Randox Laboratories Ltd., Crumlin, United Kingdom

Objectives: Synthetic cannabinoids are a large family of compounds that mimic the psychoactive effects of tetrahydrocannabinol (THC) and bind to the same cannabinoid receptors in the brain. Due to their reported cannabis-like effects when smoked, they have been banned in many countries and are prohibited in elite sport in-competition. Most of these compounds come from the JWH chemical family. Due to the large variety of stealth synthetic cannabinoid drugs available and the increasing rise in their use, immunoassays for the screening of JWH compounds, metabolites and potential metabolites are of interest for applications in test settings. For the development of such immunoassays, we report the development of two polyclonal antibodies for the determination of these compounds.

Materials and Methods: Two haptens were generated and conjugated to bovine thyroglobulin (BTG) as carrier. The resulting immunogens were administered to adult sheep on a monthly basis to provide target-specific polyclonal antiserum. IgG was extracted from the antiserum and evaluated via competitive ELISA. Absorbances were read at 450nm.

Results: Evaluation of these polyclonal antibodies revealed the following specificity profiles: one antibody recognised JWH-018, JWH-073 and JWH-200 (%cross-reactivities 100%, 135.2% and 127.1% respectively) with cross-reactivities for metabolites and potential metabolites ranging from 23.03% JWH-018 4-hydroxyindole to 215.3% JWH-018 6-hydroxyindole. The other polyclonal antibody also recognised JWH-018, JWH-073 and JWH-200 (%cross-reactivities 100%, 291.4% and 874.2% respectively) with cross-reactivity values for metabolites and potential metabolites ranging from 70.57% (3-(1-naphthoyl)1H-indole to 1505.5% JWH-018 N-5-hydroxypentyl. The cross-reactivity values for delta-9 THC, cannabinol and 11 OH delta 9-THC were <1% for both polyclonal antibodies. The antibodies did not detect other common indole-containing molecules and non-JWHCB₁-active molecules.

Conclusion: The data show that these two developed polyclonal antibodies bind to JWH compounds and metabolites. They are valuable for the development of immunoassays for the determination of these compounds in biological samples for application to different test settings.

Key Words: JWH Synthetic Cannabinoids, Antibodies, Immunoassays

JWH 250 Metabolite Identification and Reactive Metabolite Evaluation

Hua-fen Liu^{*1}, Alexandre Wang¹, Weping Zhao² and Mingshe Zhu²

¹AB Sciex, Foster City, CA, USA; ²Dept of Biotransformation, Bristol-Myers Squibb, Princeton, NJ, USA

Introduction: In 2010, the DEA announced temporarily controlling five synthetic cannabinoids: JWH-018, JWH-073, JWH-200, CP-47,497 and CP47-497 C8 homologue; other chemicals that are not yet regulated, including JWH-081 and JWH-250, have emerged to substitute the illegal ones. JWH 250 is one of the major cannabinoid agonists with phenylacetylindoles substructure. It has high binding affinity to CB1 and CB2 receptor with IC50 at 11 nM. The clinical and forensic toxicology community demands a screening method that includes both parent and metabolites. However, little work on metabolite identification has been done. We reported here the identification of JWH 250 metabolite pathway in human and also evaluated if reactive liver toxicity is a concern.

Methods: JWH-250 reference material was obtained from Cayman Chemical Company, U.S. JWH 250 was incubated in human hepatocytes as well as human liver microsomes with and without the presence of GSH and CN for reactive metabolite assessment. The *in vitro* samples were analyzed by an accurate mass LC-MSMS system. The reactive metabolite detection was also confirmed by a combined precursor -272 and neutral loss 129 as survey scan and followed by enhance product ion scan on a QTRAP® 5500 system. Chromatographic separation was performed on a Kinetex C18 2.6 μ 100mm x 3mm column at a flow rate of 0.45mL/min with mobile phase A consisting of 0.1% formic acid and mobile phase B consisting of 0.1% formic acid in acetonitrile. Accurate full scan MS and MS/MS data of metabolites were recorded with information-dependent acquisition (IDA).

Results: The most abundant metabolite in human liver microsomes indicated monooxidation of JWH 250. It was extensively metabolized in human hepatocytes to major mono and dihydroxylated metabolites and glucuronide conjugates. In addition, demethylation, N-dealkylation, carboxylation, monohydroxy metabolites in the side chain, as well as both aromatic rings and glucuronide conjugates of some oxidative metabolites, were detected in the hepatocyte incubations. In the mean time, the sulfonation conjugates of mono, di-oxidation, carboxylation, and demethylation phase I metabolites were also detected in human hepatocytes incubation. No reactive metabolite was observed in either human liver microsomes or hepatocytes. Consequently, liver reactive metabolite toxicity should not be a major concern for JWH 250. These results were confirmed by both accurate mass and QTRAP® technology. The metabolites of JWH 250 identified in the human *in vitro* systems may have higher concentrations than the parent drug in human plasma and/or urine, which may serve as better biomarkers for exposure from JWH250, as well as relevant indicators of toxicity in humans. The metabolite identification results were also applied to human urine screening to identify human subjects who may have consumed K2 spice.

Key Words: Spice, JWH250, Metabolites

Identification of Newly Distributed Designer Drugs, Synthetic Cannabinoids and Cathinone Derivatives in Japan

Nahoko Uchiyama*, Ruri Kikura-Hanajiri, Maiko Kawamura and Yukihiro Goda

National Institute of Health Sciences, Tokyo, Japan

Objectives: Many psychoactive products are globally marketed on the Internet. We have surveyed designer drugs in the Japanese illegal drug market and found that some herbal and chemical products containing new designer drugs were distributed in Japan via the Internet. In this study, we report the identification of newly-distributed synthetic cannabinoids and cathinone derivatives in these products.

Materials and Methods: More than 150 products sold in Japan in the form of herbal mixtures, solids (resins), powders and liquids were purchased via the Internet between April 2010 and March 2011. The products were extracted with MeOH under ultrasonication. After centrifugation and filtration, the methanolic extracts were analyzed using gas chromatography electron impact mass spectrometry (GC-EI-MS) and liquid chromatography electrospray ionization mass spectrometry (LC-ESI-MS). To isolate unknown compounds, the products were extracted with CHCl₃ or MeOH under ultrasonication and evaporated to dryness. After repeated fractionation of the extracts by preparative silica gel thin layer chromatography (TLC) and recycle LC, these compounds were isolated. Structure elucidation of these compounds was performed primarily by nuclear magnetic resonance (NMR) analyses and direct analysis in real time-time of flight (DART-TOF) MS or LC-ESI-quadrupole-TOFMS.

Results and Conclusion: Nine synthetic cannabinoids were identified as newly-distributed designer drugs and classified into three groups; namely phenylacetyl-, naphthoyl- and benzoyl-indoles. The phenylacetylindole group consisted of a novel compound (2-(2-Methoxyphenyl)-1-{1-[(1-methylpiperidin-2-yl)methyl]-1*H*-indol-3-yl}ethanone) and JWH-203. The naphthoylindole group consisted of AM-2201, JWH-019, JWH-122 and JWH-210. The benzoylindole group consisted of AM-694, RCS-4 and RCS-4 *o*-isomer. It is reported that AM-2201, JWH-019, JWH-122, JWH-210, AM-694 and JWH-203 have cannabinoid receptor binding activities. However, biological activities of RCS-4, RCS-4 *o*-isomer and the novel phenylacetylindole have not yet been reported. Cathinone derivatives including naphyrone, buphedrone, 4-methylethcathinone and MPPP (4-methyl- α -pyrrolidinopropiophenone), were also detected in several products. It is of interest that a few products contained both synthetic cannabinoids (potentially having cannabimimetic effects) and cathinone derivatives (potentially having stimulant effects).

Key Words: Synthetic Cannabinoids, Cathinone Derivatives, Designer Drugs

Screening for K2/Spice: Monitoring JWH-018, 073, 081 and 250 and Some Prominent Metabolites by HPLC-MS/MS**G. Brent Dawson**^{*1,2}, Alex Wang¹, and Hua-fen Liu¹¹AB Sciex, Foster City, CA USA; ²Department of Chemistry and Biochemistry, University of North Carolina Greensboro, Greensboro, NC USA

Objectives: To expand a K2/spice screening method to include JWH-81 and JWH-250 metabolites using a quadrupole-linear ion trap, to identify the metabolites and generate a spectral library. Human liver microsomes and hepatocytes were incubated with the parent drugs (JWH-018, 073, 081, 250) to generate phase I and phase II metabolites. This allowed us to predict the structures, precursor and product ions using a metabolite identification software package, and to identify the metabolites based on their product ion mass spectra.

Materials and Methods: A state of the art quadrupole linear ion trap (AB Sciex 5500 QTRAP) and High Performance Liquid Chromatography (HPLC) were used to acquire the metabolite mass spectra. The initial multiple reaction monitoring list was generated from a metabolite identification software package (LightSight®). When the multiple reactions monitoring transition generated a signal above a set threshold, the linear ion trap obtained the product ion spectrum on the metabolite precursor. Once the metabolite identification was confirmed through spectral analysis, the product ion spectra were added to a spectral library.

Results: Multiple metabolites of each parent drug were found including: alkyl chain hydroxylations, demethylations, indole ring hydroxylations, carboxylations and hydrogenations. Positional isomers of the hydroxylated phenyl ring were the most prominent for JWH-250. These metabolites were identified by a mass gain of 16 on the $m/z=121$ peak of the parent with no change in the $m/z=214$ peak of the parent, which was attributed to the carbonyl+indole+alkyl chain groups of the molecule. Also there was no mass shift in the $m/z=144$ peak of the parent, which was attributed to the carbonyl+indole fragment. Positional isomers of alkyl chain and naphthyl ring of JWH-081 were identified similarly by looking for an addition of 16 to the $m/z=127$ for the naphthyl ring or an addition of 16 to the $m/z=214$ peak of the carbonyl+indole+alkyl chain fragment. The glucuronide conjugates of these phase I metabolites were identified in the hepatocyte incubation of JWH-250. When the microsome incubation solutions were spiked into urine samples, metabolites of JWH-018, JWH-73, JWH-081, and JWH-250 could be uniquely identified through the confirmation library search algorithm of the Reporter 3.0.1 plug-in for Analyst® 1.5.1 software.

Conclusion: Many common metabolites of JWH-250 and JWH-081 were identified using the quadrupole linear ion trap. A spectral library of the most common metabolites was generated, and this library was used in a screening method to detect metabolites in urine samples.

Key Words: K2, Spice, Mass Spectrometry

P074

Capabilities of Ultra-High-Pressure Liquid Chromatography – High Resolution/High Accuracy Orbitrap Mass Spectrometry (UHPLC-HRMS) in Structural Characterization of New Amphetamine-Related and Cannabinomimetic Designer Drugs

Flavio Zancanaro, **Giampietro Frison***, Luca Zamengo, Maria Gregio, Chiara Bettin, Rocco Sciarrone
Laboratory of Environmental Hygiene and Forensic Toxicology, Department of Prevention, Azienda ULSS 12 Veneziana,
P.le Giustiniani 11e/2, I-30174 Mestre (Venezia), Italy

Introduction and Objectives: New amphetamine-related designer drugs, as well as synthetic cannabinoids, have recently been appearing more frequently on the recreational drug market. These so-called “legal highs” and “herbal highs” are sold as alternatives to controlled amphetamines and cannabis products. A growing number of countries are including these drugs under their controlled substance legislation because of their potential for addiction and associated health risks. Due to an increasing number of police seizures containing the above products there is a need to promptly characterise and identify these drugs, despite the poor availability of reference standards. This paper explores the analytical capabilities of ultra-high-pressure liquid chromatography coupled with high resolution/high accuracy Orbitrap® mass spectrometry (UHPLC-HRMS) for this purpose, in addition to traditional GC-MS techniques.

Materials and Methods: Methanolic/aqueous solutions of seized tablets or powders were analyzed by means of UHPLC-HRMS using a Thermo Scientific Accela 1250 UHPLC system equipped with a Hypersil Gold PFP analytical column (2.1 x 50 mm, 1.9 µm particle size), coupled to a Thermo Scientific single-stage Exactive HCD MS system, interfaced with an HESI-II source, operating from m/z 50 to 800 and mass resolution of 25.000 (HCD on, 25 eV) or 100.000 (HCD off).

Results: The application of UHPLC-HRMS allowed significant analytical advancements in elucidating elemental composition and structural characteristics of the new designer drugs. For example, the technique permits the accurate mass measurement of MH^+ ionic species at 100.000 resolving power under full scan conditions (experimental mass accuracy was less than 2 ppm for all designer drugs studied), and the study of MH^+ collision-induced product ions obtained in MS/MS experiments. A comparison of experimental and calculated MH^+ isotopic clusters, and the accurate examination of the relative isotopic abundances of the (M+1), (M+2) and (M+3) isotopic clusters (due to the contribution of ^{13}C , 2H , ^{15}N , ^{18}O isotopes), relative to the monoisotopic (M + 0) clusters, were also shown to be of great value.

Conclusions: The combination of the above UHPLC/HRMS applications and traditional GC-MS techniques allowed for the identification of a variety of designer drugs, including; mephedrone, 4-methylmethcathinone, methylenedioxypropylvalerone, methylone, 4-fluoroamphetamine, chlorophenylpiperazine, and the synthetic cannabinoids JWH-018, JWH-073, JWH-200, JWH-250. Based on this analytical approach an UHPLC/HRMS method for the detection of new designer drugs in biological and non-biological samples is under development.

Key Words: Designer Drugs, High-Resolution Mass Spectrometry, Orbitrap®.

An Effective and Rapid Sample Preparation Using DPX-Polar Tips for the Detection of Synthetic Cannabinoids in Urine by LC/MS/MS

Aditee P. Dalvi*, Sean E. Kocur, Louis J. Traficante
Willow Laboratories, Lynn, MA, USA

Introduction and Objectives: Many laboratories extract synthetic cannabinoids (i.e. JWH-018, JWH-073 and their metabolites) from urine by liquid-liquid extraction. We were interested in a solid phase extraction (SPE) method that was quick, easy, efficient and cost effective for day to day operation. DPX (Disposable Pipette Extraction; DPX Labs, SC) tips were chosen for this study. DPX tips are pipette tips with loosely packed sorbent material and include quick procedures for sample preparation. In this application, we validated DPX-Polar tips for synthetic cannabinoid and metabolite extraction with LC/MS/MS analysis.

Materials and Methods: This study was performed with JWH-018, JWH-073 and their metabolites (JWH-018 4-hydroxyindole metabolite, JWH-018 N-pentanoic acid metabolite, JWH-073 4-hydroxyindole metabolite, JWH-073 N-(4-hydroxybutyl) metabolite). 1 mL blank urine was fortified with standards (obtained from Cayman Chemicals; Ann Arbor, MI) to produce calibrators from 25 to 400 ng/mL; 100 ng/mL JWH-018-d9 was included as an internal standard (I.S.). 250 μ L β -Glucuronidase (5,000 units/mL) in 5.1 pH acetate buffer were added. Samples were hydrolyzed at 60°C for 2 hours, centrifuged, then extracted in <3 min per specimen using DPX-Polar column tips with methanol and deionized (DI) water. Instrumental analyses were conducted on an API 3000 Triple Quadrupole Mass Spectrometer (AB Sciex, Foster City, CA) equipped with a 5 μ m Pinnacle DB Biphenyl 50mm x 2.1mm (Restek, Bellefonte, PA) HPLC column. Mobile phases were 0.1% formic acid and 1 mM ammonium formate in (A) DI water and in (B) acetonitrile.

Results: Validation of the LC-MS/MS method was performed in our laboratory using standard procedures for acceptance. Excellent linearity was observed for the studied analytes with $r^2 > 0.99$ over the calibration range 25-400 ng/mL. Within-run imprecision ranged from 5.7 - 11.3%, while inter-day imprecision was 13.5 - 29.3%. Recovery of the analytes from urine, spiked at concentrations between 25 - 400 ng/mL, ranged from 33.1 - 112.6%. There was no carryover at 400 ng/mL and no interferences from other common drugs of abuse. LOQ and LOD were observed to be 25.0 and 6.2 ng/mL respectively.

Conclusion: We concluded that DPX -Polar tips retained and eluted the analytes of interest to give a clean extract for analysis. DPX tip-based extractions kept the LC-column and mass spectrometer cleaner than a "dilute and shoot" method. Case samples displayed a wide range of urinary metabolites. Although 4-hydroxyindole metabolites are documented in the literature to be the most abundant metabolites, we observed measurable JWH-018 N-pentanoic acid metabolite and JWH-073 N-(4-hydroxybutyl) metabolites in a majority of positive samples. Hence, we recommend looking for more than just the hydroxyindole metabolites in urine.

Key Words: LC/MS/MS, Synthetic Cannabinoids, DPX

Method Development for the Identification and Determination of Synthetic Cannabinoid Metabolites in Hydrolyzed Urine by LC/MS/MS

Amanda Rigdon*¹, Ty Kahler¹, Mike Coyer², Paul Kennedy³

¹Restek, Bellefonte, PA, USA. ²Cayman Chemical, Ann Arbor, MI, USA

Objectives: Since synthetic cannabinoids are relatively new, limited research has been performed to determine their urine metabolite profiles. Adding to analysis complexity, many metabolites are mono-hydroxylated isomers of their parent compounds. These metabolites are isobaric compounds that share a similar fragmentation pattern. These isomers are sometimes analyzed as one group, with little to no chromatographic resolution, which makes specific metabolite identification impossible. The objective was to develop an analysis method for the primary metabolites of JWH-018 and JWH-073, and to apply the methods for the analysis of these compounds in authentic samples.

Materials and Methods: The extraction used for all samples employed a high-load, endcapped 500 mg, 6 mL C18 SPE column. SPE resulted in an overall 2x sample concentration. A Shimadzu UFLC_{XR} equipped with a 5 μ m, 50mm x 2.1mm Ultra Biphenyl column (Restek, Bellefonte, PA, USA) was employed for chromatographic separation. Mobile phases were (A) water + 0.05% acetic acid (pH \approx 4.0) and (B) acetonitrile + 0.05% acetic acid. A gradient analysis, with a flow rate of 0.5 mL/min was utilized. The detector was an AB Sciex API 4000 MS/MS operated in ESI positive mode. Three multiple reaction monitoring (MRM) transitions were monitored for each metabolite based on spectra from reference standards (Cayman Chemical, Ann Arbor, MI, USA). Calibration curves ranged from 1-500 ng/mL for all metabolites, and quantification was accomplished using JWH-018 n-pentanoic acid-d4 as an internal standard.

Results: The N-pentanoic acid metabolite of JWH-018 and the 5-hydroxypentyl metabolite of JWH-018 were identified in authentic urine specimens. In addition to these metabolites, two previously undocumented metabolites were observed at substantial levels in the samples. These metabolites are tentatively identified as 4-hydroxypentyl metabolite of JWH-018 and the 3-hydroxybutyl metabolite of JWH-073. Results obtained for authentic samples are listed below (Table 1).

Table 1. Authentic urine specimen results (n=6) and MRM transitions for synthetic cannabinoid metabolites

Metabolite	Observed Level (ng/mL)	Quant MRM	Qual 1 MRM	Qual 2 MRM
JWH-018 n-pentanoic acid	< 1 - 45	372.1/155.2	372.1/127.1	372.1/144.1
JWH-018 5-hydroxypentyl	< 1 - 52	358.1/155.2	358.1/127.1	358.1/230.3
JWH-018 4-hydroxypentyl*	< 1 - 72	358.1/155.2	358.1/127.1	358.1/230.3
JWH-073 n-butanoic acid	< 1 - 14	358.1/155.1	358.1/127.2	358.1/144.1
JWH-073 3-hydroxypentyl*	< 1 - 70	358.1/155.1	358.1/127.2	358.1/144.1

*Tentative identification. Quantification performed using 5-hydroxypentyl and 4-hydroxybutyl metabolites, respectively.

Conclusions: The method presented here resolves 12 metabolites for JWH-018 and JWH-073. This method was used along with a straightforward SPE extraction to identify major metabolites in authentic samples. By using an SPE method rather than liquid/liquid extraction at high pH, the carboxylic acid metabolites of both JWH-018 and JWH-073 were recovered from fortified samples. This preliminary method may be suitable for the determination of JWH-018 and JWH-073 primary metabolites.

Key Words: Synthetic Cannabinoids, JWH-018, JWH-073

P077

Analysis of Synthetic Cannabinoids in Herbal Blends by GC Tandem Mass Spectrometry

Anthony Macherone*, Tom Gluodenis, Rafael Acosta, Ron Honnold
Agilent Technologies, Santa Clara, CA, USA

Objectives: Synthetic cannabinoids represent a new and growing list of scheduled drugs. As these newly introduced compounds become regulated, there is a need for confirmatory analysis. However, obtaining reference standards can be problematic and libraries of mass spectra can be difficult to come by. Unlike other controlled substances, the matrix is not a “pure” drug or simple pill/powder. The botanical matrix that acts as a substrate creates significant data interpretation challenges and therefore a library of mass spectra for GC Gas Chromatography (GC) single quadrupole was developed and validated. To aid with data interpretation an automated Deconvolution Reporting Software (DRS) library was developed. This tool uses a mathematical algorithm to extract spectra, search potential components against a known spectral library and generate a quantitative report for the matched compounds in the sample. An alternative approach is to isolate the targets of interest via tandem mass spectrometry. The process of multiple reaction monitoring (MRM) offers high specificity for each analyte and lower detection limits in a complex matrix. The data from tandem mass spectrometry is significantly easier to interpret and offers higher confidence in the results.

Materials and Methods: JWH-018, JWH-073, JWH-200, JWH-250, CP-47,497 (C7 analogue) and HU-210 were prepared as 5 µg/mL stock solutions. The matrix was prepared by grinding approximately 500 mg of material between two 5 in. x 5in. sheets of sandpaper until a finely divided powder was developed. Both acidic and basic liquid-liquid extractions were employed. Derivatization was achieved via commercially available BSTFA in ethyl acetate. Specific MRM transitions and collision energies were determined through a series of experiments. GC-tandem mass spectrometry facilitated chromatographic resolution and molecular specificity required to identify and quantify each of the analytes.

Results: MRMs for each analyte were found empirically to be: 324.0 -> 254.0 (12V) & 341.0 -> 167.0 (23V); 310.0 -> 254.0 (23V) & 327.0 -> 167.0 (23V); 100.0 -> 56.0 (17V) & 384.0 -> 100.0 (23); 335.0 -> 214.0 (3V) & 214.0 -> 144.0 (17V); 377.0 -> 191.0 (29V) & 377.0 -> 167.0 (33V) for JWH-018, JWH-073, JWH-200, JWH-250, CP-47,497 (C7 analogue), respectively each consisting of a quantitative transition followed by one qualifying transition. The ratio of the qualifying ion to that of the quantifier is used to further confirm positive identification of each analyte in matrix in addition to retention time information and precursor / product ion pairings. In this preliminary study, calibration curves were prepared over the range of 5 to 500 ng/mL and linearity was observed over this range.

Conclusion: Multiple reaction monitoring in GC tandem mass spectrometry offers a unique advantage over single quadrupole selected ion monitoring (SIM) in its ability to differentiate interfering matrix components from that of the analyte. The probability of an interfering ion having the same product ion spectrum is low, thus differentiation of matrix and analyte can be achieved. Through GC tandem mass spectrometry, highly selective and sensitive analytical methods in complex matrices can be developed, assuring positive identification and lowering detection limits far beyond those achieved in single quadrupole mass spectrometry. In this preliminary study, a selective and sensitive analytical method for the analysis of six common synthetic cannabinoids was developed.

Keywords: Spice, K2, GC-MS/MS

Synthetic Cannabinoid Screening Assay in Urine Specimens by LC/MS/MS**Bert Toivola***¹, Guiping Lu¹, Daniel Baker¹ and Patrick Friel²¹Sterling Reference Laboratories, Tacoma, WA, USA; ²Agilent Technologies, Seattle, WA, USA

Objectives: Synthetic cannabinoids are a popular legal alternative to the use of marijuana as a psychoactive drug. Until recently, synthetic cannabinoids were legal in most states and readily available through a variety of outlets. Synthetic cannabinoids are sold as “herbal incense” or “botanical incense” under the generic names of “Spice” or “K2” and more specifically under a variety of proprietary brand names. Spice products consist of herbal material that has been “spiked” with one or more of the following synthetic cannabinoids, JWH-018 and JWH-073. Smoking these products, although labeled “Not for Human Consumption”, produces pharmacologic effects similar to cannabis. A LC/MS/MS assay was validated to screen for the presence of JWH-018 and JWH-073 metabolites in urine specimens.

Methods: Urine samples were prepared for analysis by an initial hydrolysis with beta-glucuronidase (*Helix pomatia*) followed by liquid/liquid extraction with ethyl acetate at pH 10.2. An Agilent Technologies 1200 Series Auto Sampler and Binary Pumps coupled to an Agilent 6410 tandem mass spectrometer were used for the analysis. The LC/MS/MS was operated in the positive ion mode and multiple reaction monitoring was used for quantitation. Reversed phase chromatographic separation was achieved by gradient elution with (A) 0.1 % formic acid in water and (B) 0.1% formic acid in methanol using a 2.7 µm Poroshell 120 SB C-18 3.0 mm x 75mm column. JWH-018 N-pentanoic acid metabolite-d₄ was used as the internal standard for the JWH-018 N-pentanoic acid and JWH-018 5-hydroxyindole metabolite and JWH-073 N-butanoic acid metabolite-d₅ was used as the internal standard for the corresponding JWH-073 metabolites. The linear range of the assay was 0.2 to 500 ng/mL. The positive cutoff concentration was established at 0.5 ng/mL. The %CV (n=7) at the positive cutoff concentration was less than 20%.

Results: A total of 656 samples from various sources, including juvenile and adult probation services, treatment centers and children’s administration, were submitted for analysis. Positive results for one or more of the metabolites were obtained in 121 (18.4%) specimens; 117 (17.8%) of the specimens were positive for the JWH-018 N-pentanoic acid metabolite and 23 (3.5%) were also positive for the JWH-018 5-hydroxyindole metabolite. 98 (14.9%) specimens were positive for the JWH-073 N-butanoic acid metabolite and 3 (0.5%) were also positive for the JWH-073 5-hydroxyindole metabolite. 94 (14.3%) of the specimens were positive for both the JWH-018 N-pentanoic and JWH-073 N-butanoic acid metabolites. All specimens positive for the 5-hydroxyindole metabolite were also positive for the corresponding acid metabolites. The minimum, maximum and median concentrations of the JWH-018 and JWH-073 acid metabolites were 0.5 ng/mL, 322 ng/mL and 5.4 ng/mL and 0.5 ng/mL, 372 ng/mL and 2.9 ng/mL, respectively.

Conclusions: This LC/MS/MS assay is a robust method for the routine screening of urine specimens from subjects suspected of using “herbal incense” or “Spice” products spiked with the synthetic cannabinoids JWH-018 and/or JWH-073.

Key Words: Synthetic Cannabinoids, JWH-018, JWH-073, LC/MS/MS

Dose Dependent Disposition of the CB1 Agonist JWH-018 in the Mouse following Inhalation of the Herbal Incense “Buzz”

Dorra Amira^{1,4}, Justin L. Poklis², Laura E. Wise², Jason M. Wiebelhaus² and Alphonse Poklis^{2,3}

¹Humphrey Fellowship Program; Departments of ²Pharmacology and Toxicology; ³Pathology, Virginia Commonwealth University, Richmond, VA, USA; ⁴Laboratory of Toxicology, Emergency and Assistance Medical Center-Tunis, Tunisia

Supported by the National Institute on Drug Abuse (NIDA) Center for Drug Abuse grant P50DA005274 and the Humphrey Fellowship Program

Objective: To determine the disposition of the synthetic cannabimimetic CB1 agonist, JWH-018 in mice following exposure to smoke from the internet available herbal incense product Buzz. Presently, there are few data concerning the disposition and metabolism of JWH-018 after inhalation.

Methods: Three groups of six C57BL6 mice were exposed to the smoke of 10, 20 or 50 mg of “Buzz” determined to contain 5.4% JWH-018. The method of smoke exposure was as described previously by AH Lichtman et al. *Drug Alcohol Depend.*63:107, 2001. One hour after exposure the mice were sacrificed and blood and tissue specimens were collected. Specimens were extracted with acetonitrile and analyzed by HPLC/MS/MS as described previously by BJ Haggerty et al. *SOFT 2010, Richmond, VA.*

Results: The mean blood, brain, heart, kidney, liver, lung and spleen concentrations of JWH-018 after exposure to the smoke of 10, 20 and 50 mg of “Buzz” in ng/mL (SD) for blood and ng/mg (SD) for tissues were:

	Blood	Brain	Heart	Kidney	Liver	Lung	Spleen
10 mg	2.4 (1.3)	41 (13)	5.6 (4.0)	66 (3.9)	6.6 (3.9)	25 (16)	9.9 (6.8)
20 mg	6.1 (3.5)	30 (18)	30 (10)	48 (16)	26 (11)	228 (95)	26 (18)
50 mg	34 (33)	83 (51)	113 (17)	219 (30)	173 (12)	312 (44)	57 (39)

Conclusions: In general, blood and tissue concentrations of JWH-018 after exposure to Buzz smoke displayed a dose dependent disposition. The greater the dose of JWH-018, the higher the concentrations in tissues. The higher tissue concentrations compared to blood are consistent with JWH-018 having a large apparent volume of distribution. Relatively high kidney values may indicate urine as a major route of elimination. The presence in brain is consistent with the hypothesis that the product has behavioral effects attributable to JWH-018.

Key Words: Cannabimimetic, JWH-018, Herbal Incense “Buzz”.

Identification of the Synthetic Cannabimimetic 3-(1-Adamantoyl)-1-Pentylindole: Another Chapter in the Cat-and-Mouse Game

Stefan Kneisel*¹, Volker Brecht², Folker Westphal³, Sebastian Broecker⁴ and Volker Auwärter¹

¹Institute of Forensic Medicine, University Medical Center Freiburg, Germany; ²Institute of Pharmaceutical Sciences, Albert-Ludwigs-University Freiburg, Germany; ³State Bureau of Criminal Investigation Schleswig-Holstein, Kiel, Germany; ⁴Institute of Legal Medicine, University Hospital Charité Berlin, Germany.

Objectives: Since the end of 2008, more than 20 synthetic cannabimimetics were identified in ‘Spice’ products, demonstrating the enormous dynamic in the field of new emerging designer drugs. We report the identification of a new - and due to its substitution pattern rather uncommon - cannabimimetic found in several ‘herbal incense’ products.

Materials and Methods: Analysis of ‘herbal incense’ products (400 mg each) was performed by GC-MS (Agilent 5973, Full-Scan mode) after ethanolic extraction. Isolation of the unknown compound was achieved by TLC (Silical gel F₂₅₆, 10 x 20 cm) using cyclohexane/diethylamine (90:10 V/V) as mobile phase. Finally, after bands were scraped from the layer, the compound was extracted with ethanol. High resolution tandem mass spectrometry (HR-MS/MS) was performed using an Agilent 6530 Accurate-Mass Q-TOF LC/MS instrument, whereas structure elucidation was achieved by ¹H and ¹³C NMR (Bruker DRX-400, 400.13 MHz & 100.62 MHz).

Results: GC-MS analysis of 3 ‘herbal incense’ products, which were purchased from the same Internet seller, revealed an unknown compound present in a significant amount with a molecular ion of m/z 349. The GC-EI mass spectrum indicated a derivative of JWH-250 methylated in the α position to the carbonyl moiety. This assumption could not be confirmed, since further methylation of the enolic form failed. Therefore, a 1 g fraction was used for isolation of the unknown compound by means of TLC leading to approximately 20 mg of a brown-yellow crystalline substance. HR-MS/MS confirmed the molecular formula of C₂₄H₃₁NO, as well as the basic structure of an aminoalkylindole. Finally, ¹H and ¹³C NMR led to the identification of the compound 3-(1-adamantoyl)-1-pentylindole, a derivative of JWH-018, carrying an adamantoyl moiety instead of a naphthoyl group.

Conclusions: The presence of an adamantoyl moiety as a structural element in the class of aminoalkylindoles is new and so far has only been described in a patent specification (Makriyannis et al. 2005, US patent No. US 6,900,236 B1). Once again, this proves that due to scheduling synthetic cannabinoids, the appearance of compounds with uncommon substituents is maybe triggered. Hence, structure elucidation of unknown compounds and inclusion of new emerging cannabimimetics into routine methods is crucial in forensic analyses.

Key Words: Cannabimimetics, JWH-018 Adamantoyl Derivative

Severe Intoxications After Consumption of Products Containing Synthetic Cannabinoids – Analytical Findings Versus Clinical Symptoms

Stefan Kneisel*¹, Maren Hermanns-Clausen² and Volker Auwärter¹

¹Institute of Forensic Medicine, University Medical Center Freiburg, Germany; ²Poisons Information Center, University Medical Center Freiburg, Germany

Objectives: Since 2008, more than 20 different synthetic cannabinoids of the aminoalkylindole type were identified in ‘Spice’ products. Most have a much higher CB₁ binding affinity compared to Δ^9 -tetrahydrocannabinol (THC), indicating a significantly higher potency. We report on 39 intoxication cases since October 2008 with analytically confirmed consumption of at least one synthetic cannabinoid.

Materials and Methods: Analysis was performed using 1 mL of serum and alkaline liquid-liquid extraction followed by LC-ESI-MS/MS using a Q-TRAP 4000 mass spectrometer. The method screened for 20 synthetic cannabinoids of the aminoalkylindole type. Limits of quantification and detection were set to 0.1 ng/mL, whereas the method proved to be linear between 0.1 and 2 ng/mL. Whenever possible, samples were examined for use of other drugs by LC-ESI-MS/MS multi target screening, immunoassays and confirmatory analyses (GC-MS and/or LC-ESI-MS/MS).

Results: 39 patients (15-33 years old; 31 males, 8 females), which were taken to several hospitals within Germany, reportedly smoked ‘herbal incense’ products. LC-ESI-MS/MS analysis determined the consumption of one or more of the following compounds (number of positive samples): JWH-210 (16), JWH-122 (15), JWH-018 (9), JWH-081 (7), JWH-250 (5), AM-694 (2), JWH-073 (1), JWH-015 (1) and WIN-48098 (1). Among the symptoms reported by the emergency physicians were tachycardia (58 %), severe vomiting (29 %), somnolence (24 %), panic attacks (24 %), agitation (16 %), hallucinations (13 %), hypokalemia (11 %), generalized seizures (8 %) as well as coma (5 %).

Conclusions: In most cases, symptoms were similar to severe cannabis intoxication, but the occurrence of seizures and pronounced hypokalemia is usually not seen, even after high doses of cannabis. Thus, these compounds may be substantially more toxic than cannabis. However, interaction effects must be taken into consideration, since in one-third of the presented cases at least 2 synthetic cannabinoids were detected in the same sample. In other cases, an additional consumption of cannabis (7) and/or amphetamines (3) was confirmed. Symptoms reported emphasize the potential of these compounds for being considerably more dangerous than cannabis.

Key Words: Synthetic Cannabinoids, Intoxication, Aminoalkylindoles

Bioanalytical Quantification of MDPV; a Paranoia Inducing Designer Stimulant

Eric M. Alexy*, Laura M. Labay, and Joseph Corvo
NMS Labs, Willow Grove, PA, USA

Introduction and Objectives: Pyrovalerone is part of the β -ketone family and was first developed in the 1960s for the treatment of chronic fatigue, lethargy and weight loss. While pyrovalerone is a controlled substance in the USA and Europe, its analogue methylenedioxypropylpyrovalerone (MDPV) is not federally controlled and has been sold as a legal drug alternative. On drug user internet sites, MDPV is sold as “Research Chemicals” or “Bath Salts”. Little is known about the pharmacokinetic profile of MDPV although some metabolites have been identified. Pharmacodynamic effects of MDPV appear to be largely dose dependent. Lower doses (5-20 mg) are reported to cause mild CNS stimulation while higher doses are reported to produce effects similar to that of cocaine and amphetamine. Doses greater than 10-15 mg often result in fatigue and panic attacks. Tolerance has been noted and some users recommend pairing MDPV with common CNS depressants such as benzodiazepines, opiates and alcohol. To our knowledge no fatalities have been directly attributed to the sole use of MDPV.

Materials and Methods: At NMS Labs, the presence of MDPV in blood, serum/plasma and urine may be determined by two main analytical techniques - full scan GC-MS and LC-MS/MS. The GC-MS method functions as a qualitative screen and employs a basic extraction followed by analysis on an Agilent 6890GC with a 5975MS detector. A 12.5m, DB35MS column with a temperature ramp from 80°C to 340°C is used. The target ion is 126 with two qualifier ions of 65 and 149 that are acquired in EI mode at 70mV. The limit of detection is 10 ng/mL. The LC-MS/MS method was specifically developed for the quantitative analysis of MDPV and mephedrone, another drug that has been sold as “Bath Salts”. Briefly, 0.2 mL specimen aliquots are mixed with 10% trichloroacetic acid and internal standard (D8-MDPV and D3-mephedrone). Following centrifugation the supernatants are transferred to autosampler vials for analysis. The monitored ion transitions for MDPV are m/z 276.2 to 126.2, and m/z 276.2 to 175.2. The limit of quantification is 10 ng/mL with a linear range of 10-5000 ng/mL.

Case Report: While the number of positive cases to date has been limited, one case history was obtained. A nineteen year old male presented to the emergency department with hallucinations, both visual and auditory, and exhibiting signs of severe paranoia. A review of the medical history shows that the person had been abusing MDPV for about six months prior to this event. A urine specimen that was collected from this patient was submitted for comprehensive toxicology testing. Results of testing showed the presence of 17 ng/mL Delta-9 Carboxy THC by GC-MS and 750 ng/mL MDPV by LC-MS/MS. Surprisingly, the initial GC-MS screening of the specimen produced an acceptable library match for ropivacaine; these compounds share the same target ion of 126 and elute close to each other at 4.351 min. for MDPV and 4.497 min. for ropivacaine.

Conclusions: The case described above demonstrates the need for inclusion of MDPV in routine toxicology investigations and underscores the critical requirement for analytical specificity. The simplicity of the LC-MS/MS extraction, reduced sample requirements and run time, greater specificity, and quantitation are all examples of the advantages of the LC-MS/MS method over the GC/MS method.

Key Words: MDPV, Designer Drug, Bath Salts

Multi-Target Screening for New Designer Drugs by LC-MS/MSLars Ambach*¹ and Wolfgang Weinmann¹¹Institute of Forensic Medicine, Bern, Switzerland

Introduction and Objectives: Since the late 1990s, new designer drugs have appeared on the market beside the classical drugs of abuse. Unscheduled at the time of appearance, they allow suppliers to circumvent existing narcotics legislation. In addition to typical amphetamine and tryptamine derivatives, substances of the cathinone or piperazine class became increasingly popular and are often sold in internet shops as “bath salts”, “plant food” or simply “research chemicals”. Our goal was to develop a multi-target screening (MTS) method for urine and whole blood by liquid chromatography and tandem mass spectrometry (LC-MS/MS) able to detect the most common designer drugs as well as substances that have recently become popular.

Materials and Methods: Instrumentation consisted of a CTC PAL autosampler, an Agilent 1200 series HPLC equipped with a Synergi Polar RP column (100 × 2 mm, 5 μm, Phenomenex) and a QTrap 3200 mass spectrometer (AB Sciex). Chromatographic separation was achieved by gradient elution with mobile phase A: 1 mM ammonium formate + 0.1 % formic acid and mobile phase B: methanol + 0.1 % formic acid, a flow of 0.35 mL/min and a total runtime of 14.5 min. Isopropanol was added post-column at 0.2 mL/min. One MRM transition was used for internal standards and at least two MRM transitions for analytes. For isobaric compounds, three MRMs were used. Whole blood samples were extracted with 1-chlorobutane whereas urine samples were simply diluted prior to injection (“Dilute and Shoot” approach). Injection volume was 20 μL.

The method includes designer amphetamines (2,5-DMA, 3,4-DMA, 3,4,5-TMA, 4-MTA, DOB, DOET, DOM, ethylamphetamine, MDDMA, PMA, PMMA, TMA-6), substances of the 2C family (2C-B, 2C-D, 2C-H, 2C-I, 2C-P, 2C-T-2, 2C-T-4, 2C-T-7), aminoindanes (5-IAI, MDAI), cathinones (4-MEC, butylone, cathinone, flephedrone, mephedrone, methcathinone, methedrone, methylone, naphyrone), piperazines (BZP, mCPP, MDBP, MeOPP, p-fluoro-BZP, TFMPP), tryptamines (5-MeO-DALT, 5-MeO-DMT, AMT, DiPT, DMT, DPT, MiPT), and other compounds (desoxypipradol, ephedrine, ketamine, MDPV, norephedrine, PCP). Several deuterated and nondeuterated substances were used as internal standards (amphetamine-d5, cocaine-d3, DMPP, fenfluramine-d10, ketamine-d4, MDEA-d5, MDMA-d5, mephedrone-d3, PCP-d5).

For library-assisted identification, product ion spectra of each new substance were recorded at collision energies of 20, 35, and 50 eV as well as with collision energy spread (35 ± 15 eV).

Results and Discussion: Selectivity was tested with six blank whole blood and urine samples as well as single solutions of each analyte. The method was selective for each substance. All isobaric compounds were baseline-separated. Extraction efficiency was >60 % for all compounds and the limits of detection were between 2.5 and 10 ng/mL. Thus, the presented method enables us to reliably detect established, as well as new designer drugs, in whole blood and urine.

Key Words: Multi-Target Screening, LC-MS/MS, Designer Drugs

Ion Trap GC-MS/MS Analysis of “Bath Salts” in Biological SamplesJoseph A. Crifasi¹, **Ron Honnold***², Anthony Macherone² and Christopher W. Long¹¹St Louis University Forensic Toxicology Lab, St Louis, MO, USA; ²Agilent Technologies, Santa Clara, CA, USA

Objectives: Confident identification and quantitation of Methylenedioxypropylamphetamine (MDPV) and Naphthylpropylamphetamine (Naphyrone) in blood, urine, vitreous, gastric, and tissue matrices using GC-MS/MS methodology.

Materials and Methods: An Ion Trap Mass Spectrometer with internal ionization EI/MS/MS was used with a GC configured in a traditional capillary column mode to facilitate efficient, reproducible chromatographic separations and characteristic clean spectra to gain definite qualitative and quantitative results. Calibration samples were prepared with MDPV, Naphyrone, an internal standard (Ropivacaine) and extracted with a basic liquid-liquid extraction along with unknown samples and spiked controls. The MS/MS CID voltages were optimized using the Automated Method Development (AMD) tool in the acquisition software.

Results: MDPV, Naphyrone, and Ropivacaine neat standards were used to determine chromatographic retention times, EI full scan spectra, and identify viable precursor ions for MS/MS experiments. All compounds were found to have a characteristic precursor ion of 126 m/z, but during the collision induced dissociation (CID) each generated a unique product ion spectrum. The specific product ion spectra along with retention times were used for compound identification and quantification. The product ions monitored were 84, 124 and 97 for MDPV and Naphyrone; 84, 98 and 56 for the internal standard. The statistical LOD for all matrices was less than 1 ng/mL and the LOQ was determined to be 0.2369 ng/mL for MDPV and 0.2291 ng/mL for Naphyrone in blood, 0.2558 ng/mL and 0.0557 ng/mL in brain and 0.9263 ng/mL and 0.6768 ng/mL in liver, respectively. The LOQ for urine was found to be 0.8411 ng/mL for MDPV and 0.2553 ng/mL for Naphyrone. The calibration range for both analytes was 50 ng/mL to the ULOL at 1000 ng/mL. The imprecision for both intra and inter-assay analysis was determined to be less than 10 % for all sample types. No interfering substances have been identified. Atropine, which has a base ion in the precursor range (m/z=124) was examined for interference. The base ion did not fragment under the method conditions and the atropine peak did not co-elute with the analytes or internal standard. The technical advantage due to the MS/MS precursor through product selective m/z filtering not present in GC/MS predicts that only precursor mass fragments of exactly the same mass as MDPV, Naphyrone, Ropivacaine will never be detected.

Conclusion: Herein is presented a sensitive, selective, and robust method to determine MDPV and Naphyrone using Ropivacaine as an internal standard. The method allows for both designer drugs to be identified in blood, urine, vitreous, gastric, brain and liver tissue matrix by their unique precursor / product ion spectrum and retention times. Matrix interference was mitigated through the MS/MS processes. Two levels of positive controls were used in conjunction with negative controls to assure accurate quantification and rule out false negatives in the unknown biological samples. Low nanogram/mL detection limits were observed for both MDPV and Naphyrone in the various sample matrices. Seven replicates were run at 50 ng/mL with CV(method precision) of 5.4% and 4.2% respectively in urine extracts.

Key Words: Ion Trap MS/MS, Toxicology, MDPV, Naphyrone

Development of a Novel Benzylpiperazine ELISA Assay for Urine and Blood

Warren C. Rodrigues*, Guohong Wang, Philip Catbagan, Catherine Castro, Michael Vincent and James Soares
Immunoanalysis Corporation, Pomona, CA, USA

Introduction and Objectives: Benzylpiperazine (BZP) is a psychoactive stimulant belonging to the piperazine derived designer “party” drugs that produces euphoric effects similar to methamphetamine and ecstasy. Law enforcement agencies have reported ecstasy tablets to contain BZP. A combination of BZP, 3-trifluoromethylphenylpiperazine (TFMPP) and m-chlorophenylpiperazine (m-CPP) have been found to be the primary ingredients in 33% of seized ecstasy tablets. Toxicology laboratories have had limited success in detecting BZP using amphetamine and ecstasy homogeneous assays. There is a need for a BZP specific ELISA screen, since the only tools toxicologists currently have at their disposal are costly GC-MS and LC-MS screening methods.

Materials and Methods: The method employs competitive binding between enzyme conjugate and free analyte in the sample for a fixed amount of antibody binding sites, proportional to their concentration in the mixture. BZP specific polyclonal antibodies were raised by immunization of rabbits with BZP antigen. The immunoglobulin G (IgG) fraction was purified from the rabbit serum and immobilized on microtiter plates for the assay. The enzyme conjugate used consisted of BZP labeled with horseradish peroxidase. The sample sizes used were 10 μ L and 20 μ L respectively for urine and blood. The assay is colorimetric and absorbance was measured at dual wavelengths of 450 and 650 nm. Assay validation was also performed, which included intra-day ($n=8$) and inter-day ($n=80$) precisions, selectivity with compounds related to BZP as well as other drug classes, limit of detection (LOD) and finally authentic specimens were also screened.

Results: The LOD of the assay is 1 ng/mL for urine and blood. The urine cut-off of the assay is 100 ng/mL (1:20 sample dilution) and blood cut-off is 10 ng/mL (1:10 sample dilution). The dose response curves for urine and blood are shown in the figure below.

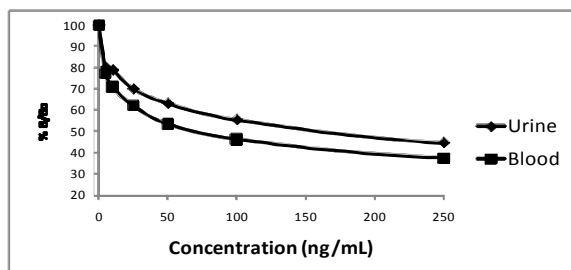

Compound	Conc (ng/mL)	BZP (ng/mL)	% CR
3-TFMPP	100,000	464	0.46
m-CPP	100,000	2083	2.08
4-MeOPP	100,000	5000	5.00
Cathinone	100,000	18	0.02
α -methyltryptamine	100,000	9	0.01
Amphetamine	100,000	157	0.16
MDMA	100,000	152	0.15

Intra and inter-day imprecisions were found to be <10%. The assay is highly specific for BZP and showed a low cross-reactivity with the compounds in the table above. In addition no cross-reactivity was detected with benzodiazepines, tricyclics, opiates, barbiturates, cocaine as well as other drugs of abuse when screened at 100,000 ng/mL. Four matched pairs of postmortem urine and blood specimens obtained from LA County Coroners Lab were screened, from which 2 pairs of urine and blood were positive, 1 pair was negative for both matrices and the last pair screened positive for blood, but negative for urine. These results matched the GC-MS screen provided, except the last urine, which was a false negative in the ELISA.

Conclusions: The described method is highly sensitive and specific for the detection of BZP in urine and blood. This assay would provide a direct method for toxicologists attempting to screen for BZP usage, as well as for postmortem drug screening.

Key Words: Benzylpiperazine, BZP, Designer Drugs, ELISA

P086

Improved GCMS Derivatization Techniques for Analysis of New Designer Drugs: Methylone, Ethylone, Butylone, Mephedrone, and Methedrone

Ryan Carrell*, Isil Dilek, Ning Chang, Uma Sreenivasan, Yunming Ying, Greg Kirkovits
Cerilliant Corporation, Round Rock, Texas, USA

Introduction: As new ‘legal high’ drugs such as methylone, ethylone, mephedrone, butylone and other methcathinone analogs increase in popularity in the international market, toxicologists require certified native and labeled reference materials to accurately identify and quantify the new compounds. There have been problems with use of deuterated internal standards of these drugs due to loss of label in the GCMS fragmentation of the derivatized compound with PFPA and BSTFA.

Objectives: To demonstrate a reliable derivatization technique and an analytical method to resolve butylone, ethylone, methylone, mephedrone and methedrone—and to demonstrate that this method applies to the deuterated analogs for use as internal standards rather than using methamphetamine-D₁₄ or other structurally different compounds.

Materials and Methods: Native and deuterated reference materials of methylone, ethylone, butylone, mephedrone, and methedrone were synthesized as HCl salts and were used to develop the derivatization method with trifluoroacetic anhydride (TFAA). The HCl salts were converted to free base with 0.1M sodium bicarbonate and heated at 60°C for five minutes with TFAA and ethyl acetate. Samples were analyzed directly by GCMS with cool-on-column injection on a DB-5ms narrow-bore (30 m X 0.25 mm, 0.25 µm ID) column. Temperature ramp: 3 min at 150°C, 150°C to 200°C at 10°C/min, 200°C to 210°C at 2°C/min.

Results: Thermally stable TFA derivatives showed increased mass spectral abundance for molecular ion and fragment ions versus the underivatized compound, with preservation of deuterium in the internal standard fragment ions. To demonstrate method robustness, five replicate mixtures of the target compounds were repeatably derivatized. Spectra and chromatography were reproducible with resolution ≥ 3 between analytes. Isotopic distribution data indicated the native ion contribution in the deuterated analogs to be $< 0.10\%$ for each compound, allowing use as internal standards. Moreover, the TFA derivative permits the analyst to distinguish between butylone and ethylone, which have the same fragment ions, but differ in the abundance of two of these ions.

Conclusion: Appropriate derivatizing reagent is essential for correct identification of methcathinone analogs and the use of deuterated internal standards for quantification. For example, this new derivatization method permits mephedrone quantification using the TFA derivative of mephedrone-D₃. Chromatographic conditions were developed to provide optimal peak width (≤ 0.1 min), resolution (≥ 3) and tailing (< 1.0) to adequately separate and analyze the targeted methcathinones. Resolution and tailing are unitless and are calculated by the ChemStation software.

Key Words: Drugs of Abuse, Methcathinone Analogs, Bath Salts

Identification and Differentiation of Methcathinone Analogues by GC-MS

Kenji Tsujikawa*, Kenji Kuwayama, Hajime Miyaguchi, Tatsuyuki Kanamori, Yuko T. Iwata and Hiroyuki Inoue
National Research Institute of Police Science, Kashiwa, Chiba, Japan.

Objectives: Recently, several methcathinone (MC) analogues such as 4-methylmethcathinone (4-MMC), 4-methoxymethcathinone, and 4-fluoromethcathinone (4-FMC), have been identified worldwide. After rapid sample preparation, analysis of authentic standards of these compounds was performed by GC-MS.

Materials and Methods: Nine MC analogues (3 regioisomers of MMCs, 3 regioisomers of FMCs, 4-methoxymethcathinone, *N*-ethylcathinone, and *N,N*-dimethylcathinone) were synthesized as HCl salts in our laboratory and examined in this study. Their freebase solution was prepared by the following method: After dissolving each analyte (100 μ g, as HCl salt) in 900 μ l of distilled water and 100 μ l of 1% ammonia solution, this mixture was extracted with 1 ml of ethyl acetate. A part (250 μ l) of this extract was evaporated under a nitrogen stream and redissolved in same volume of ethyl acetate. These samples were submitted for GC/MS analysis within 1 day. GC/MS analysis was performed by a Shimadzu GCMS-QP5050A equipped with a split/splitless injector (injector temperature: 250°C, injection volume: 1 μ l). Chromatographic separation was performed with a DB-5ms capillary column (30 m X 0.25 mm X 0.25 μ m). The oven temperature was held at 80°C for 1 min, and then raised to 320°C at 15°C/min. The mass spectrometer was operated in EI mode (scan, range: *m/z* 40-500).

Results and Discussion: The MC analogues were partially degraded to their dehydrogenated products when their freebases were analyzed in splitless mode. This thermal degradation was almost completely prevented by split injection. This indicated a shorter residence time in the hot injector prevented the decomposition. Furthermore, evaporating freebases solution of MC analogues under the stream of nitrogen, most of the analytes showed a substantial loss (> 30%), while DMF (2.5 μ L) addition prior to evaporation prevented this loss. GC-MS analysis of the regioisomers of MMCs and FMCs showed resolved peaks with similar mass spectra. These results suggest that seized materials suspected of containing MC analogues should be analyzed by GC-MS in the split mode and without concentration after solvent extraction. GC-MS analysis of authentic standards allows the differentiation of the positional isomers of MMCs and FMCs. In conclusion, our results gave useful information for the forensic analysis of MC analogues.

Key Words: Methcathinone Analogues, Thermal Degradation, Loss by Solvent Evaporation

Bizarre Behavior and Death Following Ingestion of MDPV (“Bath Salts”)

Lauren L. Richards-Waugh, Kristen M. Bailey, Myron A. Gebhardt, **David J. Clay***, Christina L. Newsome-Sparks, Hamada E. Mahmoud, and James C. Kraner
Office of the Chief Medical Examiner, 619 Virginia Street West, Charleston, WV 25302, USA

Introduction and Objectives: The compound 3,4-methylenedioxypropylamphetamine (MDPV) was first synthesized in 1969 as a methylenedioxy analogue of amphetamine. MDPV acts as a monoamine reuptake inhibitor, with actions focusing mainly on norepinephrine and dopamine and some effect on serotonin. It is approximately twice as potent as amphetamine and four times as potent as methylphenidate. MDPV has a chemical structure and pharmacodynamic profile similar to that of MDMA and methcathinone. Products containing MDPV are marketed as “bath salts”, legally available in smoke shops, “head” shops, and over the internet in many states. These products are labeled “not for human consumption”. Recreational users anecdotally report that a typical dose of approximately five to ten milligrams of “bath salts” produces increased energy, sociability, limited (if any) euphoria, mental stimulation, increased concentration, aphrodisiac, and empathogenic effects. High or frequent doses may cause cocaine- or methamphetamine-like highs and can lead to severe and prolonged anxiety, agitation, panic attacks (anxiety, tremor, physical agitation, irritability, dry mouth, increased heart rate), depression, suicidal thoughts, anhedonia, confusion, paranoia, insomnia, and altered vision. Adequate reference ranges for this drug are not yet available.

Case History: Presented here is a fatality of a 47-year-old male who was reported by family members to have been abusing “bath salts” for at least two weeks, exhibiting symptoms of paranoia and insomnia consistent with excessive use of MDPV. The decedent caused a disturbance near his home, reportedly running down the street in only his boxer shorts and a t-shirt while yelling, kicking over trash cans, and carrying his laptop because he believed someone was trying to take it away from him. He assaulted an individual before police arrived at the scene. While attempting to restrain the man, law enforcement noted he was combative and displayed excessive physical strength before suddenly going limp. Emergency medical services found the subject in cardiac arrest and he was later pronounced dead at a local hospital following unsuccessful attempts at resuscitation. MDMA and related products are known to cause significant disturbances of cardiac rhythm, which can result in cerebral vascular accident, ruptured cardiac vessels, and fatal cardiac arrhythmia/arrest.

Results and Conclusion: The decedent’s home and vehicle were searched following the incident. An empty, plastic container bearing the designation “White Girl” was seized from the decedent’s vehicle. Investigation of the decedent’s home revealed overturned furniture, significantly damaged walls, and debris strewn about. Blood and urine samples submitted to the toxicology laboratory, as well as the residue from the plastic container, were positive for MDPV, caffeine and lidocaine. MDPV was quantitated in the blood and urine at concentrations of 1.09 and 60.3 mg/L, respectively. Although the final determination of cause of death is awaiting completion of the comprehensive death investigation, preliminary postmortem findings indicate that MDPV was a likely contributor to death by causing a fatal cardiac arrhythmia.

Key Words: MDPV, Stimulants, Designer Drugs

Determination of Cathinone Derivatives and Other Designer Drugs in Serum by Comprehensive LC-Triple Quadrupole MS/MS Analysis

Madeleine J. Swortwood* and Anthony P. DeCaprio

Department of Chemistry and Biochemistry and International Forensic Research Institute, Florida International University, Miami, FL, USA

Introduction: In recent decades, clandestine drug lab operators have attempted to bypass controlled substance laws and legal regulations with “designer” compounds similar to current drugs of abuse including methamphetamine, ecstasy, and khat. Presently, “bath salts” have erupted onto the drug scene as “legal highs” containing cathinone analogs that have produced severe side effects in users across the globe. These compounds are the newest additions to the already growing list of substances that fall into the various classes of designer drugs.

Objective: The purpose of this study was to develop an LC-MS/MS based method for the comprehensive analysis of multiple designer drugs across the various classes in a single analytical run with low LOQ. The compounds chosen included DOB, 2C-B, MDA, MDMA, MDEA, amphetamine, methamphetamine, ethylamphetamine, mephedrone, cathinone, methcathinone, methedrone, flephedrone, butylone, methylone, 4-methylethcathinone, BZP, DBZP, mCPP, TFMPP, and DMT. Ultra-trace analysis was felt to be important because many of the compounds may be found in blood at extremely low levels, *e.g.*, due to high potency or as contaminants in what a user may otherwise believe to be a popular drug such as Ecstasy.

Methods: Drug standards (purchased from Lipomed and Cerilliant) were analyzed on an Agilent 1290 Infinity Binary Pump coupled to an Agilent 6490 triple quadrupole LC-MS/MS with UHP 1290 Infinity UHPLC with Jet Streaming technology and electrospray ionization (ESI). Separation occurred on an Agilent Zorbax Rapid Resolution HD Eclipse Plus C₁₈ threaded column (50 x 2.1 mm, 1.8 μm particle size). After the chromatographic method was optimized for all compounds, the drug mixtures were spiked into human serum with deuterated internal standards (amphetamine-D₆, MDMA-D₅, mephedrone-D₃, methylone-D₃, BZP-D₇, and TFMPP-D₄) and extracted using mixed-mode solid-phase extraction cartridges with hydrophobic C₁₈ and cation exchange sites (Restek SPE Drug Prep I, 3 mL, 200 mg). Data acquisition was performed in MRM mode with positive ESI using one principal MRM transition for quantitation and 1-2 additional transitions to serve as qualifiers. Method validation parameters were fully evaluated, including selectivity, matrix effects, recovery, process efficiency, stability, linearity, precision, and accuracy.

Results: The assay was selective for all of the tested analytes in a run-time of 6 minutes under gradient conditions for concentrations in the range of 1 pg/mL to 100 ng/mL. Limits of quantitation were determined by analyzing the signal-to-noise ratios and were calculated in the range of 1 to 100 pg/mL. In particular, eight cathinone derivatives were identified and quantified with high sensitivity and selectivity. The method proved to be specific, accurate (bias <15% of the nominal value), and precise (<15% of the R.S.D.) across the calibration range. Matrix effects were negligible.

Conclusions: The developed LC-QQQ-MS/MS method is suitable for the ultra-trace analysis of twenty or more specific designer drug entities, including the most recent cathinone derivatives, in human serum. Future work will incorporate additional compounds among the various designer drug classes.

Key Words: Legal Highs, Designer Drugs, LC-MS/MS, Cathinones

P090

Stability of Cathinones in Whole Blood Samples

Lambert K. Sørensen*.

Section for Toxicology and Drug Analysis, Department of Forensic Medicine, Aarhus University, Brendstrupgaardsvej 100, 8200 Aarhus N, Denmark

Objectives: The stimulating alkaloid cathinone is found in the leaves of the shrub khat (*Catha edulis*). Chewing of khat has spread from Africa and the Arabian Peninsula and gained an increasing global prominence. In addition to the native cathinone available from the khat plant, a broad range of cathinone derivatives has been synthesized. Thus, testing for cathinones in blood from vehicle drivers is pertinent and requires knowledge on the stability of these drugs.

Methods: The stabilities of cathinone, methcathinone, ethcathinone, amfepramone, mephedrone, flephedrone, methedrone, methylone, butylone, cathine, norephedrine, ephedrine, pseudoephedrine, methylephedrine and methylpseudoephedrine in antemortem blood samples preserved with NaF/potassium oxalate and NaF/citrate buffer were tested at storage temperatures of $20 \pm 2^\circ\text{C}$ and $5 \pm 2^\circ\text{C}$. The additives resulted in sample pHs of 7.4 and 5.9, respectively. The samples were analyzed by a multi-component LC-ESI-MS/MS method using a simple and rugged extraction with methanol.

Results: The stability of cathinones in blood samples is clearly influenced by pH. In blood samples preserved with NaF/potassium oxalate, the measured concentrations of cathinone, methcathinone, ethcathinone, mephedrone and flephedrone declined by 30% after two days of storage at 20°C . When the blood samples were preserved with NaF/citrate buffer, the loss was reduced to 10%. Amfepramone, methedrone, methylone and butylone also decomposed but less rapidly. At a storage temperature of 5°C , the decomposition proceeded with a markedly lower rate, but a trend was still observed after 3-6 days of storage for samples preserved with NaF/potassium oxalate. Related ephedrines, which contain a hydroxyl group instead of the ketone group at the β position, were stable over the same storage periods regardless of pH and temperature. The stability of cathinones in sample extracts obtained from protein precipitation with methanol was also clearly pH-dependent; in the pH range of 2.5-3.5, no significant degradation was observed after a week of storage at $20 \pm 2^\circ\text{C}$.

Conclusions: The study revealed that in whole blood specimens sample pH and temperature during shipment and storage of samples and extracts are critical variables to be considered in the determination of cathinones. If precautions are not taken, the accuracy and applicability of analytical results may be influenced.

Key Words: Cathinones, Whole Blood, Stability

A Newly Found Mephedrone Analogue – 4-Methylethcathinone Legally Dealt on the Czech and Slovak Drugs of Abuse Market

Viktor Vorisek^{1*}, Vilma Fürmanova¹, Jiri Kunes², Milan Pour² and Vladimir Palicka¹

¹Institute of Clinical Biochemistry and Diagnostics, Department of Clinical and Forensic Toxicology, Medical Faculty of Charles University and University Hospital Hradec Kralove, Czech Republic; ²Department of Inorganic and Organic Chemistry, Charles University in Prague, Faculty of Pharmacy in Hradec Kralove, Heyrovskeho 1203, CZ-500 03 Hradec Kralove, Czech Republic

Objectives: The objective of this study was to identify the previously unknown compound in so-called bathsalts, “Dream”, “Mystic Night”, “Sweet Kiss” and/or “Jacuzzi”. These products are available on the internet or through many disreputable coffee shops in the Czech Republic and the Slovak Republic.

Methods: MS spectra after electron ionization (EI) were obtained from a GC-MS ITQ 1100 system equipped with a BPX5 forte column (30m x 0.25mm x 0.25µm). The scan range was $m/z = 40-400$ (full ms). The ion source temperature was maintained at 200 °C. The scan speed was 4 µscans and the maximal ion time was 35 ms. NMR spectra were recorded for CDCl₃ solution at ambient temperature on a VNMR S500 NMR spectrometer operating at 500 MHz for ¹H and 125 MHz for ¹³C. Chemical shifts were recorded as δ values in parts per million (ppm), and were indirectly referenced to tetramethylsilane (TMS) *via* the solvent signal (7.26 ppm for ¹H and 77.0 ppm for ¹³C). Coupling constants (*J*) are given in Hz.

Results: MS-EI without derivatization of samples: 44, 72, 91, 119, 146, 174 and 192 *m/z* (molecular ion) MS-EI, after derivatization with trifluoroacetyl anhydride (TFAA): 91, 119, 140, 168 and 288 *m/z* (molecular ion).

¹H NMR (500 MHz, CDCl₃) δ 10.48 (1H, s, NH₂), 9.12 (1H, bs, NH₂), 7.88-7.83 (2H, m, AA', BB', H2, H6), 7.31-7.26 (2H, m, AA', BB', H3, H5), 5.11-4.99 (1H, m, NCH), 3.30-3.06 (2H, m, NCH₂), 2.41 (3H, s, CH₃), 1.79 (3H, d, *J*=7.3 Hz, CH₃), 1.51 (3H, t, *J*=7.3 Hz, CH₃)

¹³C NMR (125 MHz, CDCl₃) δ 194.3, □ 145.9, 130.5, 129.9, 129.0, 57.9, 42.0, 21.8, 16.7, 11.8

Conclusion: The unknown substance was identified as 4-methylethcathinone, (MEC or 2-ethylamino-1-(4-methylphenyl)propan-1-one or 2-ethylamino-1-p-tolylpropan-1-one). NMR spectral analyses and GC-MS results identified this mephedrone analogue in all four above mentioned powders as being the primary drug.

Key Words: Mephedrone Analogue, GC-MS, NMR, 4-Methylethcathinone

Simultaneous Determination of Mephedrone, Methylone, MDPV, and Amphetamines in Urine by LC/MS/MS

Amanda Rigdon^{1*}, Mike Coyer², Jack Cochran¹, Ty Kahler¹, and Paul Kennedy³

¹Restek, Bellefonte, PA, USA; ²Northern Tier Research, Mayfield, PA. ³Cayman Chemical, Ann Arbor, MI, USA

Introduction and Objectives: Abuse of substances marketed as ‘research chemicals’ often sold for research purposes only or added to consumer products labeled ‘not for human consumption’ has become increasingly popular. Cathinones, including mephedrone, methylone, and MDPV, are one class of compounds that have appeared on the market as part of the ‘research chemical’ movement. These compounds are commonly sold as bath salts, however drug users often snort or ingest these compounds to induce an amphetamine-like high. Although these compounds have not yet been scheduled, some laboratories have added testing for cathinones to their analyses. If these substances become scheduled drugs, demand will increase for routine testing for cathinones. Since these compounds are structurally similar to amphetamine and may be taken in lieu of amphetamine, adding them to an existing amphetamine screen can save laboratories time and expense. The objective of this project was to develop a fast, quantitative LC/MS/MS method for the simultaneous determination of mephedrone, methylone, MDPV, amphetamine, methamphetamine, MDA, MDMA, and MDEA in urine.

Materials and Methods: An LC/MS/MS method was developed for the determination of cathinones and amphetamines in urine. The LC/MS/MS method employed a 5 μ m, 50 mm x 2.1 mm Ultra Biphenyl column. Liquid chromatography utilized a Shimadzu UFLC_{XR}, and tandem mass spectrometry was achieved on an AB Sciex API 4000 operating in ESI positive mode. Three transitions were used for each analyte. Mobile phase A consisted of water with 0.2% formic acid, and mobile phase B contained methanol with 0.2% formic acid. The flow rate used for analysis was 0.6 mL/min, and total analysis time including re-equilibration was 4.5 minutes. Samples were prepared with a 10:1 dilution in starting mobile phase containing 5 ng/mL of amphetamine-D₆. The calibration curve used for analysis ranged from 1 ng/mL to 500 ng/mL.

Results: Linearity (r) for all compounds across the calibration range was 0.9980 – 0.9995. Signal-to-noise for all compounds at 1 ng/mL ranged from 4:1 to 67:1. Accuracy for QC samples (n=3, 40 ng/mL) was 92% - 112%. RSD for QC samples ranged from 4% - 7%. RSD for internal standard response across all injections was 4%. Urine from a user who admitted to ingesting “Ivory Wave” approximately 8 hours prior to sample collection showed an MDPV level of 116 ng/mL.

Conclusion: The method presented here allows for fast, routine analysis of mephedrone, methylone, and MDPV simultaneously with amphetamines by LC/MS/MS.

Keywords: Mephedrone, LC/MS/MS, Cathinones

Early Detection of Methcathinone and Related Compounds in Blood and Urine

Vilma Fürmanova*, Viktor Vorisek, and Vladimir Palicka. Institute of Clinical Biochemistry and Diagnostics, Medical Faculty of Charles University and University Hospital Hradec Kralove, Czech Republic

Objectives: We present the first known cases involving methcathinone and related compounds found in biological samples from the Czech Republic. These new designer drugs have become readily available on the drug abuse market; however, they are still not scheduled in the Czech Republic. The aim of this work is to illustrate the need to include methcathinone, mephedrone and other beta-keto designer drugs and their metabolites in routine toxicological analysis for drugs of abuse in blood and urine. For inconclusive findings by immunoassay and HPLC-DAD screening, urine samples from all cases were screened and confirmed by GC-MS for beta-keto designer drugs. The samples were prepared by liquid-liquid extraction from an alkaline medium with and without derivatization (acetylation).

Case 1: Urine from an 18-year-old male was sent for toxicological analysis when he presented with symptoms of nausea and stomach pain. Immunoassay screening results were positive for THC and negative for amphetamines. A commercial HPLC-DAD screening (Prominence TOX.I.S., Shimadzu) was also performed and results were compared with an automated spectral library search. Cathinone and MDEA were identified. GC-MS screening confirmed methcathinone and cathinone, and traces of mephedrone, cathine, pseudoephedrine, and MDMA.

Case 2: Blood and urine samples from a 26-year-old female were analyzed due to intoxication from an unknown substance. Immunoassay results were positive for benzodiazepines in both serum and urine, and negative for other common drugs and medicines. An automated HPLC-DAD screening of the urine showed indefinite results. GC-MS screening in urine confirmed methcathinone and metabolites; LC-MS/MS screening in serum confirmed flunitrazepam and zolpidem.

Case 3: Urine from a 16-year-old male was sent for routine toxicological examination by his pediatrician. Immunoassay results were positive for THC and negative for amphetamines. HPLC-DAD screening using a spectral library search identified cathinone. GC-MS screening confirmed methcathinone, cathinone and metabolites, and pseudoephedrine.

Case 4: A 33-year-old male attempted suicide using oral buprenorphine (Subutex). Blood and urine samples were sent for toxicological analysis. An immunoassay screening was positive for benzodiazepines in serum; the urine was positive for benzodiazepines and buprenorphine. Alcohol was not detected in serum. The HPLC-DAD screening identified cathinone and mephedrone with the spectral library search. GC-MS screening confirmed methcathinone, cathinone and metabolites, and pyrovalerone.

Discussion: In this study, the results show that beta-keto designer drugs can be detected in biological samples using the workup procedure and the GC-MS method used for identifying amphetamines in urine. It is important to test for these drugs in systematic toxicological analysis.

Key Words: Methcathinone, Case reports, GC-MS

2-Diphenylmethylpyrrolidine (Desoxy D2PM): Another Pipradrol Analogue

Malgorzata Puchnarewicz^{1*}, John Ramsey², David W Holt¹, Atholl Johnston¹

¹Analytical Unit, St. George's, University of London, UK; ²TICTAC Communications Ltd, St George's, University of London, UK

Objectives: In the last few years rapid development in the novel drug market has led to an increased number of laboratories reporting unknown/unidentified compounds. The Analytical Unit is involved in screening biological specimens for the new designer drugs from a number of rehabilitation centres and Accident and Emergency (A&E) departments. One of our recent findings was the identification of 2-Diphenylmethylpyrrolidine (Desoxy D2PM) in a urine sample from a drug therapy centre. This compound is closely related to 2-diphenylmethylpiperidine (desoxypipradrol, 2-DPMP) and diphenylprolinol (D2PM); it is believed to have similar psychoactive properties. Currently there are no data on the pharmacology of the compound and very limited analytical data. The supplier of the compound, as a laboratory chemical, states an application is for enantiomeric determination of chiral carboxylic acids. There has also been a separate report of its use as an ingredient in nutritional supplements. The presence of Desoxy D2PM in the biological sample was confirmed using gas chromatography/mass spectrometry (GC/MS) and liquid chromatography/mass spectrometry (LC/MS/MS).

Materials and Methods: (S)-(-)-Desoxy D2PM was purchased from Sigma-Aldrich. Desoxy D2PM was isolated from urine using liquid-liquid extraction (sodium hydroxide, methyl-tert-butylether). GC/MS analysis was performed using a Shimadzu GC-MS-QP2010 with a Shimadzu AOC-20i autosampler. Helium was used as the carrier gas and an HP-5MS column (30m x 0.25mm, 0.5µm film thickness) was employed for separation. The injector port was held at 225°C. The initial column temperature was set at 80°C and held for 4 minutes. It was ramped by 20°C per minute up to 280°C held for 5 minutes, ramped by 40°C per minute up to 290°C and held for a further 15 minutes,. Positive electron impact ionization (EI) was used. Desoxy D2PM eluted after 14.12 minutes and the most intense fragment ion was m/z 70.

The HPLC system consisted of a Perkin Elmer PE200 Series autosampler, pump and column oven. Chromatography was achieved using an Alltech Alltima C18 (150 x 2.1mm, 5µm) column maintained at 50°C. The mobile phase consisting of methanol/de-ionized water/2M ammonium acetate/formic acid (48/52/0.1/0.1, v/v), was pumped at 250 µL/min. Detection was by LC/MS/MS, using a Sciex API2000 triple quadrupole equipped with a turbo-ion spray interface. The method was run in positive ionisation mode and monitored precursor and product ions of Desoxy D2PM with m/z: 238.2 and 91.2, 117.0, respectively.

Results: Desoxy D2PM was detected in our routine GC/MS assay for drugs extracted under alkaline conditions. The presence of the compound was confirmed by LC/MS/MS against a reference standard.

Conclusion: Routine screening for basic drugs potentially allows the determination of a range of new designer drugs but depends on many factors, including access to reference standards and up-to-date library databases. Aspects such as sensitivity, stability and recovery are still to be established, using laboratory collaborations and information exchange to expedite assay developments.

Key Words: Desoxy D2PM, Novel Drug, Collaboration

A Validated Quantitative Method for Analysis of MDPV and Mephedrone (Bath Salts) in Urine Using LC-MS/MS**Guiping Lu***¹, Bert Toivola¹, Daniel Baker¹ and Patrick Friel²¹Sterling Reference Laboratories, Tacoma, WA, USA; ²Agilent Technologies, Seattle, WA, USA

Introduction: Bath salts are new members of designer drugs. They were first reported in the US in late 2009 and early 2010. Bath salts typically contain methylenedioxypyrovalerone (MDPV) and/or mephedrone, which act as central nervous system stimulants resulting in a “high” similar in effect to methamphetamine, ecstasy and/or cocaine. However, using bath salts can cause adverse side effects, such as increased heart rate and blood pressure, insomnia, nausea and vomiting, hallucination, extreme paranoia and anxiety, and seizures. Several deaths associated with use of bath salts have been reported in the US. Currently, MDPV and mephedrone are not scheduled under the Controlled Substance Act if not intended for human consumption.

Objective: To develop and validate a quantitative method using LC-MS/MS for analysis of MDPV and mephedrone in urine of patients suspected of using bath salts.

Materials and Methods: Urine samples were added with the internal standards (IS), MDPV-d8 and mephedrone-d3, adjusted to pH 2-3 and extracted using cation exchange SPE columns. The extract was dried down, reconstituted and analyzed using an Agilent 1200 LC coupled with 6460 triple quadrupole MS. The analysis was performed on a Polaris C₁₈ 50 × 2.0 mm (5 μm particle size) column with a total run time of 4.2 min. The mass spectrometer was operated in positive ion mode with ESI. Two MRM transitions were monitored for each analyte and IS.

A series of calibrators at concentrations from 1 to 5000 ng/mL were made in urine to determine the LOD (limit of detection), LOQ (limit of quantification), linearity and precision of the method. Carryover was checked by running the 5,000 ng/mL calibrator in five replicates followed by a blank sample or samples spiked to 40% of cutoff. Additionally, five compounds, which have structures similar to MDPV and mephedrone, were spiked into the 50 ng/mL calibrator to verify absence of interference.

Results: Although this method can reach lower detection limit, 1 ng/mL, which produced an average S/N of 19 ± 6 and 24 ± 9 (five replicates) for MDPV and mephedrone, respectively, was determined administratively as the LOD. LOQ was 5 ng/mL because 80% accuracy was obtained at this concentration when a calibration curve from 5 to 5000 ng/mL was developed. This method has excellent linearity from 5 to 5000 ng/mL with R² of > 0.999. Because currently no regulated cutoff values are set for MDPV and mephedrone, 25 ng/mL was decided administratively as suitable for the method. Imprecision of the method was acceptable at < 5% relative standard deviation at five replicates. No carryover or interferences were observed.

Conclusions: This method is an easy, robust method that can be used for screening and confirmation of MDPV and mephedrone in urine of patients suspected of using bath salts.

Key Words: MDPV, Mephedrone, Bath Salts, LC-MS/MS

Concept for Methods for the Prompt Identification of New Psychoactive Substances

Karen Rofe* and Sheila Hardwick

Home Office Centre for Applied Science and Technology, Sandridge UK

Introduction: The rate at which ‘New Psychoactive Substances (NPS)’ for example, mephedrone, desoxyipradrol and naphyrone, are appearing in the United Kingdom (UK) has been accelerating. They are sold on the internet, in “head shops” and by dealers. Users are generally unaware of the chemical nature of the substances which, in some circumstances were reported to cause severe ill-effects.^{2, 3} In response to this problem, the current UK coalition government aim to introduce a system which will place a temporary ban on NPS while health issues are considered by experts. A substance can only be temporarily banned for 12 months; therefore, it is essential that information regarding the chemistry, toxicology and pharmacology of the psychoactive substances is determined as soon as possible after the material is first encountered. For experts to obtain a perspective on the prevalence of a new psychoactive substance, it is essential that toxicology laboratories have access to the necessary chemical standards.

Objectives: The work presented describes how the UK Home Office, together with a syndicate of forensic providers, consisting of experts from academia, private companies and across UK government, have been working to establish ways of identifying the chemical structure of previously unseen NPS, so that chemical standards can be made available to operational laboratories. Initial work has included the analysis of over 100 ‘test purchase’ samples, the sharing of data, and decision making over which analytical techniques should be used.

Results and Discussion: Data obtained from this exercise including the 15 NPS identified (e.g. benzedrone, alpha methyl tryptamine, and desoxy-D2PM) and the GC-MS and high resolution LC-MS-MS techniques used will be described with a way forward for the future identification of NPS in case-work samples.

References:

¹EMCCDA Definition: A ‘New Psychoactive Substance’ means a new narcotic or psychotropic drug in pure form or in a preparation.

²<http://www.scribd.com/doc/30196961/Association-of-Chief-Police-Officers-New-Psychoactive-Substances-Guidance-Website>

³<http://www.telegraph.co.uk/news/uknews/7458101/Police-investigate-deaths-of-two-teens-linked-to-mephedrone.html>

Key Words: Psychoactive, Operational, Identification

Fluoro-and Methyl-Ephedrine Metabolites in Routine Urine Testing for Designer Stimulants

Victor Uralets*, Sumandeep Rana and Wayne Ross
Redwood Toxicology Laboratory, Santa Rosa, CA, USA

Introduction and Objectives: Synthetic designer stimulants derived from cathinone have become widely abused in the US. Redwood Laboratory performs routine testing for these drugs in urine based on the detection of parent drugs. In this study, routine positive human urine samples were further investigated in order to identify potential non-conjugated metabolites of different synthetic cathinones and to evaluate their analytical importance.

Materials and Methods: Un-conjugated stimulants are isolated from urine by liquid/liquid extraction in alkaline conditions and then derivatized with trifluoroacetic anhydride. A qualitative screen is followed by quantitative confirmation performed by gas chromatography/mass spectrometry operating in selective ion monitoring (SIM) mode. Confirmation methods are fully validated for the quantitative detection of the parent compounds.

Results: Large scale routine testing has provided the opportunity for observing the most common metabolic patterns in free un-conjugated fraction of human urine. Fluoro-ephedrine, fluoro- ψ -ephedrine and their respective nor- metabolites (identified by the mass spectra) were found to be the major components of all flephedrone (4'-fluoromethcathinone) positive urine samples, whereas parent drug was minor. It points to the conclusion that flephedrone strictly follows cathinone metabolism - reduction of β -keto- into hydroxy- group. Similarly, methyl-ephedrines (methyl group in the aromatic ring) dominated chromatograms of the mephedrone (4'-methyl-methcathinone) positive urine samples. Interestingly, keto-reduced metabolites were either very small or not detected at all in MDPV, methylone and butylone positive urines, suggesting that methylendioxy attachment restricts or inhibits β -keto reduction.

Conclusion: Based on the prevalence of fluoro- and methyl- ephedrine metabolites in random positive specimens, their use as markers is preferable for the detection of flephedrone and mephedrone abuse.

Key Words: Designer Stimulant Metabolites, Human Urine, Gas Chromatography/Mass Spectrometry

P098

Analysis for Mephedrone (4-Methylcathinone) in Rat Plasma and Rat Brain Homogenates by Liquid Chromatography-Mass Spectrometry

David M. Andrenyak*, Gregory C. Hadlock, Diana G. Wilkins, James W. Gibb, Glen R. Hanson, and Annette E. Fleckenstein.

Department of Pharmacology and Toxicology, Univ. of Utah, Salt Lake City, UT, USA

Supported by NIDA grants: DA00869, DA04222, DA13367, DA11389, DA019447, and DA09407.

Objectives: Mephedrone (4-methylmethcathinone) is an amphetamine-like compound that has euphoric and stimulant effects similar to methamphetamine and MDMA. Mephedrone has recently emerged as a recreational drug and has been implicated in several human fatalities. This analytical method was developed to measure mephedrone concentrations in rat plasma and brain homogenates in support of studies investigating mephedrone's pharmacological mechanisms in rats.

Methods: Rat brains were weighed and homogenized separately in 10 mL of ultra-pure water using a Vibra Cell™ homogenizer (Sonics, Newtown, CT). A 0.5 mL volume of plasma or brain homogenate was transferred to separate, silanized 16 x 100-mm glass tubes. Mephedrone and mephedrone-d₃ reference materials were obtained from Cerilliant® (Round Rock, TX). Separate sets of calibrators (1 to 500 ng/mL) and control samples at 8, 80, and 240 ng/mL were prepared in blank rat brain homogenate or blank rat plasma. Mephedrone-d₃ (30 ng) was added as the internal standard. For the extraction, 0.1 mL of ammonium hydroxide and 4 mL of 1-chlorobutane:acetonitrile (4:1, v/v) was added to each tube. After mixing and centrifuging, the upper organic layer was transferred to separate glass tubes, and dried with air at 40°C in a TurboVap® evaporator (Caliper Life Sciences, Hopkinton, MA). A 0.1 mL volume of 0.2 % formic acid:methanol (75:25, v/v) was added to each tube. The reconstituted extracts were transferred to separate polypropylene autosampler vials. Liquid chromatography tandem mass spectrometry (LC-MS-MS) was performed with an Acquity™ liquid chromatography column interfaced to a Quattro Premier™XE tandem quadrupole mass spectrometer and controlled with MassLynx™ v4.1 software (Waters, Milford, MA). Chromatographic separation was achieved on a Synergi™ MAX RP (4µm, 150 x 2 mm) LC column (Phenomenex®, Torrance, CA) with a 0.2 % formic acid:methanol (75:25, v/v) mobile phase (0.2 mL/min flow rate). Positive ion electrospray ionization was employed. Selected reaction monitoring was used to analyze for the mephedrone (m/z 178→160) and mephedrone-d₃ (m/z 181→163).

Results and Conclusion: The mephedrone and mephedrone-d₃ peaks were Gaussian and eluted at approximately 4 mins. The standard curve r² values were greater than 0.99. Plasma matrix selectivity studies using 6 different blank rat plasma sources showed no endogenous peaks eluting at the retention time for mephedrone. Mephedrone intra-assay accuracy was within 7 % of target concentrations in rat plasma and brain controls. Intra-assay coefficient of variations were within 7 % and 9 % for the rat plasma and brain, respectively. Recoveries were 96 % and 75 % for brain and plasma respectively at 80 ng/mL. The analytical method was applicable for measuring mephedrone concentration in rat plasma and rat brain following 10-25 mg/kg s.c. mephedrone injections.

Keywords: Mephedrone, Plasma, Brain, LC-MS-MS

Routine Screening of Human Urine for 14 New Designer Stimulants Found in “Bath Salts” Using GC/MS

Sumandeep Rana*, Victor Uralets and Wayne Ross
Redwood Toxicology Laboratory, Santa Rosa, CA, USA

Introduction: Synthetic designer stimulants produced in clandestine labs and sold on-line or at smoke shops as “Bath Salts” or “Plant food” are causing great concern amongst healthcare agencies. The White House Office of National Drug Control Policy, National Drug Intelligence Center and U.S. Poison Control Centers have all issued alerts about these synthetic stimulants, noting the ease of access concerns and the number of nationwide emergency room visits related to these drugs. However, there is very little information regarding the prevalence of these drugs in the drug user population mainly because they are not routinely analyzed. In this study, 14 designer stimulants including cathinones and piperazines were analyzed in over 2000 routine urine specimens.

Methods: Designer stimulants included in the routine analysis are: amphetamines (MDA, MDMA, MDEA, MBDB), cathinones (Methylone, Ethylone, Butylone, Cathinone, Methcathinone, MDPV, Mephedrone) and designer piperazines (BZP, TFMPP and mCPP). Parent drugs were extracted from alkalized urine specimens using liquid/liquid extraction with methyl *tert*-butyl ether and then derivatized with trifluoroacetic anhydride. GC/MS screening analysis was performed in electron ionization mode by selective ion monitoring (EI - SIM) using a single quadrupole mass spectrometer with inert ion source. A 230 volt GC oven was used to enable fast temperature programming and hydrogen was used as carrier gas. Separation was performed on a narrow bore column (10 m X 0.15 mm i.d.). Three ions for each analyte and two ions for the internal standard (MDMA-D5) were monitored. Presumptive positives were subjected to separate quantitative GC/MS confirmatory analysis using fully validated methods.

Results: 2051 authentic urine specimens received from drug court programs were analyzed for 14 designer stimulants reported to be the active ingredients of products like Ivory Wave, Cloud Nine and many others that are sold as “Bath Salts” and/or “Plant Food”. 159 (7.7%) were found to be positive for one or more drug. In the positive specimens, methylenedioxypyrovalerone (MDPV) was the most commonly found drug and was detected in 140 (88%) of the specimens with urine concentrations ranging from 60 -37000 ng/mL (LOQ 50 ng/mL). Methylone was the second most abundant analyte found and was present in 33 (20.7%) of the specimens either alone (13) or in combination with MDPV (17) and other drugs (3). Mephedrone was found in 5 specimens, butylone in 2, trifluoromethylphenylpiperazine(TFMPP) and benzylpiperazine (BZP) in one specimen each.

Conclusion: As of May 15th, 2011, 6 out of the 14 designer stimulants tested by Redwood Toxicology Laboratory are Schedule 1 substances banned by the Drug Enforcement Administration (DEA). The remaining 8 chemicals, including MDPV, the most frequently encountered drug, remain legal and readily available. The high positive rate of these drugs in routine specimens suggests the need for measures to control these substances and to include designer drug testing as a part of routine drug testing.

Key Words: Designer Stimulants, Human Urine, Gas Chromatography/Mass Spectrometry

P100

WITHDRAWN

Determination of Blood Cyanide in Several Poisoning Cases

Kayoko Minakata*, Kunio Gonmori, Hideki Nozawa, Itaru Yamagishi, Koutaro Hasegawa, Kanako Watanabe and Osamu Suzuki

Hamamatsu University School of Medicine, Hamamatsu, Japan

Introduction and Objectives: Cyanide (CN^-) is a lethal toxin and its rapid and decisive determination in blood is necessary to indicate exposure from various sources, including chemical compounds, combustion byproducts, and some types of food. A number of methods have previously reported the detection of CN^- in blood; however, a large blood volume is required and methods include evaporation, as well as derivatization, which are time consuming. In addition, the detection was from a single MS for the confirmation of CN^- and its derivatives. Our aim was to develop a new method using tandem mass spectrometry (MS–MS) and a small sample volume. The analytical method was applied to specimens from several poisoning cases.

Materials and Methods: An aliquot of 5 μL blood was hemolyzed with 50 μL of water and 5 μL of 1 M tetramethylammonium hydroxide and 2 μL of 10^{-4} M NaAuCl_4 were added. $\text{Au}(\text{CN})_2^-$ was produced and extracted with 75 μL of methyl isobutyl ketone. 10 μL of the extract were injected directly into an ESI–MS–MS instrument. CN^- quantification was performed by selected reaction monitoring of the product ion CN^- at m/z 26, derived from the precursor ion $\text{Au}(\text{CN})_2^-$ at m/z 249. CN^- was measured in the quantification range of 2.6 to 260 $\mu\text{g/L}$ with a limit of detection of 0.56 $\mu\text{g/L}$ in blood.

Results: The concentrations of CN^- in blood from normal subjects and intoxicated subjects were as follows: 7.13 ± 2.41 $\mu\text{g/L}$ for six healthy non-smokers, 3.08 ± 1.12 $\mu\text{g/L}$ for six victims of carbon monoxide poisoning, 730 ± 867 μg for 21 house fire victims and 3030 ± 97 $\mu\text{g/L}$ for a victim who ingested NaCN . An elevated CN^- level in the blood of a victim who ingested NaN_3 was also confirmed using our MS–MS method. The concentrations of CN^- in blood, gastric content and urine were 78.5 ± 5.5 , 11.8 ± 0.5 and 11.4 ± 0.8 $\mu\text{g/L}$, respectively.

Conclusion: Measurement of cyanide is essential in fire victims and suspected poisonings, and the present method enables toxicologists to perform an accurate diagnosis of cyanide poisoning in less than 10 minutes using only 5 μL of blood.

Key Words: Cyanide, Blood, Tandem Mass Spectrometry

Histopathological Evaluation of Organs in Cases of Fatal Pesticide Poisoning

Tanuj Kanchan

Associate Professor, Department of Forensic Medicine and Toxicology, Kasturba Medical College (Affiliated to Manipal University), Mangalore 575001, India

Objectives: Poisoning is one of the leading causes of morbidity and mortality worldwide and an important health hazard. The purpose of the present research is to evaluate the histopathological changes in the human organs in cases of fatal pesticide poisoning.

Materials and Methods: This autopsy based analysis was carried out at Kasturba Medical College, Mangalore. A detailed profile of fatal poisoning cases was made based on the hospital and autopsy records, information furnished by the police and chemical analysis reports from the Regional Forensic Science Laboratories (RFSL). In cases of suspected poisoning, a piece of liver, spleen, both lungs and kidneys were preserved in formalin during the autopsy and subjected to histopathological examination. Cases confirmed with a diagnosis of pesticide poisoning from the RFSL that did the histopathology were included to study organ changes. A series of 14 cases obtained during 2009-2010 were studied in detail.

Results: Organophosphorus compounds (OPCs) were responsible for the fatal outcome in 12 cases. Presence of zinc phosphide and aluminium phosphide were confirmed in the other two cases. Manner of death was suicide in all, and individuals were predominantly (85.7%) male. Mean age of the victims was 41 years with a range of 20 to 60 years. Period of survival ranged from 0-10 days. On histological examination, the liver showed hepatic parenchyma with fatty changes, sinusoidal dilatation, and focal areas of necrosis with mixed inflammatory infiltrate. Congested red pulp of the spleen was evident in most cases. Besides, varying degree of congestion, kidneys showed features suggestive of acute tubular necrosis in some cases. Lung parenchyma had varying degrees of congestion, oedema, and haemorrhage. Pneumonic changes were observed in a few cases.

Conclusion: The study illustrates the histopathological changes in fatal pesticide poisoning in Mangalore, South India. Histopathological evaluation of organs in general, revealed varying degrees of congestion and oedema of the organs. India is predominantly an agriculture based country, and easy availability of agrochemicals appears to facilitate fatal self-poisoning.

Key Words: Histopathology, Poisoning, Organophosphates

Toxicokinetics and Detection of ACTP-Ester Residues in Goat Using HPLC

Chittaranjan Sahu and B. Bagchi

University of Kalyani, Kalyani, West Bengal, India

Objectives: ACTP-Ester (Triclopyr butyl) is a selective herbicide widely used in agriculture to control woody plants and broad leaf weeds and was first introduced to the market by Dow Elanco, USA. The objective of the present study was to evaluate the kinetic parameters of ACTP-Ester and recovery of its two potential metabolites triclopyr acid (3,5,6-trichloro-2-pyridinyloxy acetic acid, M_1) and trichloro-pyridinol (3,5,6-trichloro-2-pyridinol, M_2) following administration of the compound to black Bengal goats (*Capra capra*). Since goats are an important source of meat and milk, there is a high risk of contamination of herbicides in human beings through the food chain.

Materials and Methods: ACTP-Ester (79.2 mg/Kg) was orally administered to each experimental goat ($n = 24$, 4 groups of $n = 6$, for collection of samples at different times). The control group ($n = 2$) was treated with same amount of carboxymethyl cellulose (CMC). Blood samples were collected before (0 h) and at 0.25, 0.50, 0.75, 1, 2, 3, 4, 6, 8, 12, 24, 36, 48, 60, 72, 84, 96, 120, 144 and 168 h post dose and were processed for high performance liquid chromatography (HPLC) analysis. ACTP-Ester toxicokinetic parameters were determined by computerized interactive curve fitting of blood concentration/time profiles and various disposition kinetic parameters were calculated using standard formula. Urine and feces samples were collected every 24 h from 24 to 168 h. Animals were sacrificed on days 4, 5, 6 and 7 days for collection of different tissues and gastrointestinal tract contents that were analyzed for drug and metabolite recoveries.

Results: ACTP-Ester was first detected in blood at 0.5 h ($2.1 \pm 0.05 \mu\text{g/mL}$, $n = 6$), followed by a peak concentration at 6 h of $6.6 \pm 0.1 \mu\text{g/mL}$, gradually decreasing to $0.9 \pm 0.02 \mu\text{g/mL}$ at 48 h. The absorption rate constant (K_a , $0.3 \pm 0.01 \text{ h}^{-1}$) was poor. A low β value ($0.05 \pm 0.007 \text{ h}^{-1}$) coupled with a long elimination half life ($t_{1/2\beta}$, $15.0 \pm 1.8 \text{ h}$) and lower total body clearance value (Cl_B , $0.4 \pm 0.03 \text{ L/Kg/h}$) suggested a slow rate of elimination. The low K_{el} value ($0.08 \pm 0.008 \text{ h}^{-1}$) also suggested that ACTP-Ester was slowly eliminated from the central compartment, resulting in long-term ACTP-Ester persistence in the blood. The overall % ACTP-Ester dose recovered from urine, feces, GI tract contents and tissues was 64.9, 65.6, 68.2 and 69.3% in goats sacrificed on days 4, 5, 6 and 7 respectively. The recovery of M_2 from GI tract contents was poor compared to ACTP-Ester. The recovery of ACTP-Ester from urine was lower than M_1 and M_2 . Remaining M_1 was recovered from different tissues on day 4 and from the small intestine on day 5 onwards. M_2 was detected in all tissues except bile, the adrenal gland, ovary, bone and blood.

Conclusion: ACTP-Ester toxicokinetic behavior followed 'two compartment open model kinetics'. The low absorption rate constant suggested relatively slow absorption from the GI tract. The Cl_H and the equivalent Cl_B value suggested that the major route of ACTP-Ester elimination was through the liver.

Key Words: Toxicokinetics, Residue, ACTP-Ester

Homicidal Aluminium Phosphide Poisoning - A Case Report**H. V. Chandrakant*** and M. Arun

Department of Forensic Medicine and Toxicology, JSS Medical College, JSS University, Mysore-570015 Karnataka, India

Introduction: Homicidal poisoning is rarely reported in the literature. Every case of poisoning, whether acute or chronic, has medico-legal overtones. While a majority of poisonings are suicidal or accidental, homicidal cases are quite rare. Most of the famous historical, homicidal poisonings have less information on the criminal investigative analyses, than on the psychological profiles of the poisoners or their victims. An ideal homicide would involve the smallest dose of a lethal poison with the least likelihood of detection.

Case History: We present a case report of homicidal poisoning involving aluminum phosphide, an unlikely candidate. A 45-year old female was brought to JSS medical college mortuary with a history suggestive of food poisoning. The brother found his sister lying on the floor and his mother in a gasping state. They were immediately taken to the nearest hospital where the young lady was pronounced dead. The mother was put on ventilator support and finally recovered sufficiently to give a report of the incident. The accused was a priest who owed the mother 100,000 Indian rupees. On the ill-fated day, the accused brought a sweet meat mixed with aluminium phosphide and claimed he had performed a special blessing of the meat and the offering was not be shared with anyone but the mother. As the elderly woman was suffering from diabetes mellitus, she ate only a small portion while the daughter consumed the remainder, leading to her death. Autopsy conducted on the daughter revealed stomach contents with 50 mL of indistinguishable material and mucosa with a garlicky odor. All the viscera were intact and congested. Viscera and vomitus collected from the crime scene and the container confiscated from the accused were sent for chemical analysis to a regional forensic science lab. Color tests of the visceral extract revealed the presence of phosphide ions. Further testing with a UV spectrophotometer revealed a lambda maximum between 430-450 nm confirming the presence of phosphide ions. Cause of death was attributed to respiratory failure as a result of phosphide poisoning. The trial ended by sentencing the accused to life imprisonment based on the autopsy report, chemical analysis, corroborative evidence and a self-confession from the accused. Aluminium phosphide is readily available in Indian markets, and is commonly used as pesticide. It is sold in the form of tablets mixed with urea and ammonium carbonate in sealed airtight containers.

Conclusion: This presentation emphasizes the need for precautions to be taken while handling these substances in daily life.

Key Words: Aluminum Phosphide, Homicidal Poisoning, Pesticide, UV Spectrophotometer

Fatal Poisoning with *Taxus Baccata*: Quantification of Paclitaxel, 10-Deacetyltaxol, Baccatin III, 10-Deacetylbaccatin III and Cephalomannine (Taxol B) and of 3,5-Dimethoxyphenol in Post Mortem Body Fluids by LC-MS/MS

T. Grobosch^{*1}, B. Schwarze², D. Stoecklein², T. Binscheck¹

¹Berliner Betrieb für Zentrale Gesundheitliche Aufgaben (BBGes), Institute of Toxicology and Poison Information Centre Berlin, Oranienburger Str. 285, 13437 Berlin, Germany; ²Friedrich-Alexander-Universität Erlangen-Nürnberg, Department of Forensic Medicine, Universitätsstr. 22, 91054 Erlangen, Germany

Objectives: This method was developed to confirm the fatal ingestion of toxic yew plant material in post-mortem samples (stomach content, urine, femoral blood, cardiac blood, bile and brain tissue) collected from a 22-year-old man who committed suicide by ingesting an unknown amount of yew leaves.

Materials and Methods: The analytical method was based on a liquid-liquid-extraction under alkaline conditions followed by LC-MS/MS analysis. The method allows the simultaneous identification and quantification of the commercially available yew alkaloids taxoids (m/z): paclitaxel (854.2->105.0/286.1), 10-deacetyltaxol (812.2->105.0/286.1), baccatin III (604.0->105.0/327.0), 10-deacetylbaccatin III (562.1->105.0/327.0), cephalomannine [taxol B] (562.1->105.0/327.0) and of 3,5-dimethoxyphenol (155.0->111.9/122.9) also encompassing the qualitative analysis of the alkaloidal diterpenoids (Q1->194.0/107.0); reference mass spectra obtained from a yew leaves extract: monoacetyltaxine (568.4), taxine B (584.2), monohydroxydiacetyltaxine (626.4), triacetyltaxine (652.4), monohydroxy-triacetyltaxine (668.4).

Results: The initial hypothesis of yew tree (*Taxus baccata*) poisoning was confirmed. The quantitative evaluation revealed the taxoids in all samples (except brain tissue) whereas 10-deacetylbaccatin III showed the highest concentrations (µg/L): 7.3 (femoral blood), 12 (cardiac blood), 132 (stomach content), 200 µg/L (urine), 290 (bile). In urine, after enzymatic hydrolysis, the concentration of 3,5-dimethoxyphenol (3,5-DMP) was 23,000 µg/L. The qualitative analysis showed alkaloidal diterpenoids present in all post-mortem samples. Other plant toxins like colchicine, digitoxin or digoxin were not detected by LC-MS/MS analysis.

Discussion: The newly developed LC-MS/MS method enables the identification of alkaloidal, non-alkaloidal diterpenoids and 3,5-dimethoxyphenol in post mortem body fluids and tissues for the confirmation of accidental or intentional poisonings with yew plant material.

Key Words: Fatal Poisoning, European Yew (*Taxus Baccata*), LC-MS/MS

P106

WITHDRAWN

Concentration Distributions of *d,l*-Methadone in Peripheral Blood from Forensic Autopsies, DUID Suspects and Users of Illicit Drugs

Anita Holmgren,* Johan Ahlner and Alan Wayne Jones

Department of Forensic Genetics and Forensic Toxicology, National Board of Forensic Medicine, Artillerigatan 12, SE-587 58 Linköping, Sweden

Background: Methadone, a synthetic opioid analgesic, hit the headlines internationally in 1965 when Dole and Nyswander described its usefulness for treatment of heroin addicts. Methadone maintenance treatment (MMT) represented a paradigm shift in the rehabilitation of individuals dependent on narcotics, helping them to kick the habit and preventing relapse. Besides its use in treatment of heroin addiction, methadone is now widely prescribed for pain management, with negative consequences including diversion from the licit to the illicit drug market and many overdose deaths.

Methods: In this retrospective study, we used a forensic toxicology database (TOXBASE) to find cases with methadone verified present in venous blood from apprehended drivers (N = 594), users of illicit drugs (N = 315) and in femoral blood from autopsy cases (N = 503). The analysis of methadone in blood was done by capillary column gas chromatography with a DB-5 stationary phase and nitrogen-phosphorous detector after solvent extraction with butyl acetate. Methadone was identified from its relative retention times using two different internal standards (allobarbital and prazepam) and also with a second stationary phase (DB-17). The limits of quantitation for reporting positive results were 0.05 mg/L in blood from the living and 0.1 mg/L in postmortem blood.

Results: In methadone-related deaths the mean, median and (range) of methadone concentrations were 0.51 mg/L, 0.30 mg/L (0.1-6.7 mg/L), compared with 0.23 mg/L, 0.20 mg/L (0.05-1.1 mg/L) in DUID suspects and 0.22 mg/L, 0.20 mg/L (0.05-0.80 mg/L) in people arrested for using illicit drugs. The concentration of methadone was >0.5 mg/L in 9.7% of living cases and 37% of autopsy cases (p<0.001). Males dominated in each of these forensic materials; autopsy cases (83%), DUID suspects (90%) and users of illicit drugs (89%), although their median age was about the same 34-38 y regardless of gender. In autopsy cases, 69% of deaths were attributed to drug overdose (median methadone 0.4 mg/L) and 31% had other causes e.g. trauma, natural (median methadone 0.3 mg/L). The median blood methadone concentration decreased as the number of co-ingested drugs increased; 0.5 mg/L (methadone only, N = 33) and 0.2 mg/L (methadone + 7-10 other drugs, N = 27). Benzodiazepines, especially diazepam and alprazolam, were the most prevalent co-ingested prescription drugs along with methadone in the living and the dead. Ethanol (>0.2 g/L) was found in 4% of the living and 18% of the dead. The illicit recreational drugs most often used together with methadone were amphetamine, Δ^9 -tetrahydrocannabinol, and morphine, the later derived from abuse of heroin.

Conclusions: Over the 11-year study period (2000-2010), there was an appreciable increase in the number of forensic cases in which methadone was verified present in forensic blood samples. There was a considerable overlap in the concentration distributions of this opioid analgesic between the living and the dead, making it difficult to conclude that methadone toxicity was the cause of death. Interpretation of toxicology results is complicated owing to risk for adverse drug-drug interactions and inter-individual differences in tolerance to opiates.

Key Words: Autopsy, DUID, Methadone

Internet – Assisted Suicide (with pharmaceuticals)

Douglas E. Rohde^{*1} and Alixe M. Sheedy²

¹Lake County Crime Laboratory, Painesville, OH, USA; ¹Cleveland State University, Cleveland, OH, USA; ²Indiana University – Purdue University Indianapolis, Indianapolis, IN, USA

Objectives: After attending this presentation, attendees will gain insight into the use of pharmaceutical preparations in the commission of suicide and recognize the role of individuals in the dissemination of such information via a global system of interconnected computer networks.

Case History: A 21-year-old female residing in Lake County, OH with a history of attempted suicide was linked to a double suicide in California through e-mail correspondence. Investigation revealed the female supplied a 35 year old male and his 73 year old mother with materials and instructions needed to create a pharmaceutical preparation known as a “Darvon Cocktail”. Contact between these individuals was initiated and propagated via a suicide discussion group on the internet.

The female was found to have in her possession the following pharmaceutical drugs, most of which are listed as components of the “Darvon Cocktail”: propoxyphene, alprazolam, clonazepam, phenobarbital, oxycodone, prochlorperazine, ondansetron and domperidone.

Routine postmortem toxicology testing was performed on the 35-year-old male yielding the following results: propoxyphene – blood-central (B-C) 10 mg/L, blood peripheral (B-P) 14 mg/L, liver 160 mg/kg, gastric >760 mg; norpropoxyphene – B-C 7.7 mg/L, B-P 14 mg/L, liver 110 mg/kg; diazepam – gastric 70 mg. The following drugs were also detected in one or more specimens: phenobarbital, midazolam, triazolam, hydroxytriazolam, ondansetron and prochlorperazine.

Routine postmortem toxicology testing was performed on the 73-year-old female yielding the following results: propoxyphene – B-C 7.7 mg/L, B-P 3.6 mg/L, liver 25 mg/kg, gastric >710 mg; norpropoxyphene – B-C 2 mg/L, B-P 4.5 mg/L, liver 36 mg/kg; diazepam – gastric 130 mg. The following drugs were also detected in one or more specimens: phenobarbital, midazolam, triazolam, hydroxytriazolam, temazepam and ondansetron.

Discussion: Further investigation of the 21-year-old female’s e-mail account revealed recent contact with at least six other individuals seeking information on the “Darvon Cocktail”, including a confirmed suicide victim in NY and a possible connection in the UK. The number of suicide chat rooms is increasing and while there are laws that exist to punish those who assist others with suicide, there are currently no controls on suicide web sites. Propoxyphene was banned in the UK, EU, NZ, US and SW; however, these bans were primarily a result of reported cardiac events.

Key Words: Suicide, Internet, Darvon Cocktail

Detection of Pentobarbital in Teeth Recovered from Skeletonized Remains by Microwave Assisted Extraction and Gas Chromatography-Mass Spectrometry

Caroline C. Betit*¹, James H. Watterson¹, Dorothy E. Dean² and John F. Wyman³

¹Departments of Forensic Science, Chemistry & Biochemistry, Laurentian University, Sudbury, Ontario, Canada; ²Summit County Medical Examiner's Office, Akron, OH, USA; ³Cuyahoga County Regional Forensic Science Laboratory, Cleveland, OH, USA

Objectives: Detection of pentobarbital (PB) by gas chromatography-mass spectrometry (GC/MS) in teeth of decomposed remains following a novel microwave assisted extraction (MAE) procedure is described.

Materials and Methods: As part of an earlier study investigating drug stability in decomposing tissues [1], a domestic pig received an oral cocktail of drugs (75 mg/kg amitriptyline, 7.5 mg/kg diazepam, 0.8 mg/kg morphine and 7 mg/kg citalopram). The animal was then anaesthetized by injection of PB (30mg/kg PB, IP) and subsequently euthanized by a lethal intracardiac injection of PB (390 mg). The remains decomposed in a secure outdoor environment in rural Ohio for over 2 years. Bones were collected and teeth (molar, premolar) were removed. Drug free porcine teeth were used as a negative control. Teeth were cleaned with phosphate buffer (PBS, 0.1 M, pH6), methanol and acetone, then dried under ambient conditions, and pulverized with a domestic grinder and pooled. Ground teeth were sampled in triplicate (2 g) and underwent MAE in methanol at atmospheric pressure in a domestic microwave oven (1100W) for 16 minutes. The extraction solvent was replaced with fresh methanol after 0, 1, 3, 5, 7, 10 and 13 minutes of irradiation and the aliquots were combined for further analysis. The combined methanol extracts were evaporated to approximately 1mL. The volume was then adjusted to 4mL with phosphate buffer (0.1 M, pH 6) and secobarbital (SB, 50 ng) was added as an internal standard. Samples then underwent a lipid/protein precipitation step with 1:1 acetonitrile:methanol prior to mixed-mode solid phase extraction (SPE) for basic drugs. Columns were conditioned with methanol, water and PBS and samples were loaded by gravity. Columns were washed sequentially with PBS and 0.1 M acetic acid. PB was eluted with 3 mL methanol, and the basic fraction was eluted with 6 mL 80:17:3 ethyl acetate:isopropanol:ammonium hydroxide. The basic fraction was assayed by UHPLC for the presence of amitriptyline, diazepam or citalopram and no drugs or metabolites were detected (limit of detection of all drugs – 25 ng/mL reconstituted tissue extract). Methanolic extracts were evaporated to dryness and reconstituted in ethyl acetate (EA) and derivatizing agent (TMPAH) was added before analysis. GC/MS analysis was done in the SIM mode, where ions monitored were m/z 112, 169 and 184 (PB) and 181,195 and 196 (SB).

Results and Discussion: This assay has a detection limit of approximately 5 ng/mL PB (based on 1 mL initial solution). PB was detected in the extracts of teeth from the drug exposed animal, suggesting systemic drug distribution throughout the body or contamination by liquefaction of soft tissue surrounding the teeth during decomposition, since oral exposure to the drug can be ruled out. To the authors' knowledge this is the first demonstration of MAE of PB from dental tissue, and one of the first demonstrations suggesting that teeth may provide toxicological information in postmortem work involving highly decomposed remains.

References:

1. Wyman JF, Dean DE, Yinger R *et al.* the Temporal Fate of Drugs in Decomposing Porcine Tissue. J Forensic Sci, 2011 56(3), 694-699

Key Words: Forensic Toxicology, Microwave Assisted Extraction (MAE), Teeth, Pentobarbital

A Fatal Case of Simultaneous Ingestion of Mirtazapine, Escitalopram and Valproic Acid

E. Gerace*¹, A. Salomone¹, D. Di Corcia¹ and M. Vincenti^{1,2}

¹Centro Regionale Antidoping "A. Bertinaria", Orbassano, Turin, Italy; ²Dipartimento di Chimica Analitica, Università degli Studi di Torino, Turin, Italy

Introduction and Objectives: A fatal case involving the concomitant intake of mirtazapine, escitalopram and valproic acid is reported. Mirtazapine and escitalopram are antidepressant drugs currently prescribed by psychiatrists for the treatment of depression. Valproic acid has been used as an anticonvulsant drug since 1967, but it has more recently been employed in the treatment of the manic depressive phase of bipolar disorders. These drugs are more recent than traditional tricyclic antidepressants (TCA) and are reported to be less toxic; however, intoxication due to overdose has been repeatedly reported.

Case Report: In the present case, a 64-year-old woman with a previous history of chronic depression was found dead in her apartment. Several packages of pharmaceutical drugs were found, including mirtazapine, escitalopram and valproic acid. During the autopsy, no evidence of natural disease or trauma was found to account for this death. In order to determine whether massive drug consumption might have caused a lethal intoxication; heart blood, urine and gastric contents were collected and submitted for toxicological analyses.

Specific LC-MS/MS protocols were developed and validated. Blood concentrations of mirtazapine, escitalopram and valproic acid were 20.3 mg/L, 65.5 mg/L and 417 mg/L, respectively. Urine concentrations were 17.0 mg/L, 94.5 mg/L and 423 mg/L. High concentrations of these drugs were also detected in the gastric contents confirming their ingestion shortly before death.

Conclusion: The agreement between autopsy examination by forensic pathologists and toxicological findings confirmed the suicidal hypothesis. The cause of death was by drug intoxication due to simultaneous high-dose ingestion of mirtazapine, escitalopram and valproic acid.

Key Words: Lethal Intoxication, Antidepressant, Suicide

Association Between Antipsychotic Drugs and Sudden Cardiac Death

F. Aknouche*¹, P. Kintz², G. Quatrehomme³, R. Buti¹, E. Guibert¹, V. Maignant¹, and H.P. Duval¹. ¹Laboratoire Bio6Med, Antibes, France; ²X-Pertise Consulting, Mittelhausbergen, France; ³Institut Médico-Légal, Nice, France

Objective: To describe the relationship between neuroleptic drugs and a sudden cardiac death involving a psychotic patient.

Case report: A young woman was hospitalized with a diagnosis of refractory schizoaffective disorder. The week prior to hospitalization she received clozapine therapy, 25 mg/day; the dose was increased to 50 mg/day upon hospital admission. She was further prescribed cyamemazine 300 mg/day, alimemazine 30 mg/day, and zopiclone 7.5 mg/day if needed. The subject died one week after admission to the hospital. A forensic death investigation was requested by her father.

Methods: An autopsy was performed and biological specimens were collected including femoral blood, neck blood, gastric contents, and hair. Both blood specimens and gastric content were analyzed for clozapine, cyamemazine, alimemazine, loxapine, zolpidem and hydroxyzine using an alkaline liquid-liquid extraction with dichloromethane-isopropanol-n-heptane. All specimens were analyzed by gas chromatography mass spectrometry (Focus GC with column TR5MS - PolarisQ, Thermo Fisher Scientific, Courtaboeuf, France). Hair analysis for the same analytes consisted of approximately 30 mg of hair, incubated overnight in Sorensen phosphate buffer in the presence of diazepam-d5 as internal standard, and then extracted by a mixture of dichloromethane-ethyl ether. Detection of drugs in hair was achieved by liquid chromatography on an X-Terra MS C18 column, followed by detection on a MS/MS system.

Results: The following results were obtained from the analysis of the biological specimens. A dash indicates the specimen contained no detectable analyte above the LOQ.

	Clozapine	Cyamemazine	Alimemazine	Loxapine	Zolpidem	Hydroxyzine
Femoral Blood (ng/mL)	660	540	250	65	---	---
Neck Blood (ng/mL)	480	480	56	96	---	---
Gastric Contents (mg/kg)	1.8	6.5	0.07	0.91	---	---
Hair (pg/mg)	---	221	104	---	1356	47

Conclusion: In this psychiatric case, clozapine and cyamemazine were associated with a lengthening of the rate corrected QT interval (QTc) on the electrocardiogram. Lengthening of the QT interval often precedes wave burst arrhythmias and can degenerate into ventricular fibrillation. The high levels of both clozapine and cyamemazine in blood along with the presence of loxapine (which was not prescribed) were considered contributing factors in the cause of death; the medical care provided to the decedent was called into question.

Key Words: Clozapine, Cyamemazine, Loxapine

Evaluation of the i-STAT®1 Handheld Analyzer for Postmortem Vitreous Humor Chemistry Analysis

Monique A. Oles*, Matthew P. Juhascik and Amanda J. Jenkins

UMassMemorial Department of Hospital Labs. Forensic Toxicology Laboratory, Worcester, MA, USA

Introduction and Objectives: In postmortem forensic toxicology the determination of electrolytes and glucose may assist the pathologist in determining the cause of death. These analyses are typically performed on automated chemistry analyzers in a clinical setting. This study evaluated the performance of the Abbott Point of Care i-STAT®1 handheld analyzer (Abbott Park, IL) for vitreous humor (VH) chemistry testing within the postmortem forensic toxicology laboratory. The objective was to determine whether i-STAT®1 measurements were as reliable as those performed by a high throughput clinical laboratory analyzer, the Synchron LX®20 System (Beckman Coulter, Brea, CA).

Materials and Methods: Vitreous humor specimens [N=54], collected as part of the routine autopsy protocol performed by the Office of the Chief Medical Examiner, State of Massachusetts, were analyzed by both methodologies on the same day.

Results: The mean values for sodium were 140 and 151 mmol/L by the iSTAT and LX20, respectively; chloride, 118 and 115 mmol/L; glucose, 201 and 216 mg/dL; urea nitrogen [UN], 36 and 24 mg/dL; creatinine, 1.7 and 1.6 mg/dL; and CO₂, 15.0 and 11.2 mmol/L. Student t-tests were performed in Microsoft Excel on each paired data set. A p-value below 0.05 was considered statistically significant. Sodium, chloride and urea nitrogen concentrations were significantly different between the iSTAT and LX20. If clinical significance is evaluated using normal VH chemistry ranges suggested by Coe of sodium 131-150 mmol/L; Chloride 104-130 mmol/L and UN 3-30 mg/dL, 46% Na results were within the normal range with the iSTAT but elevated with the LX20. Further, 5.5% Cl results were normal with the iSTAT but low with the LX20, and 13% UN were elevated with the iSTAT but normal with the LX20. Statistical significance was not observed for glucose (p = 0.83); creatinine (p = 0.74); or CO₂ (p = 0.10).

The importance of VH chemistry analysis in determining cause of death was illustrated by five case studies. Case histories included diabetes, possible starvation, and renal failure. When assayed with the iSTAT, three cases had elevated urea nitrogen [greater than 75 mg/dL], one case with glucose greater than 700 mg/dL, one case with sodium greater than 180 mmol/L. The potassium level was greater than 9.0 mmol/L in all 5 cases.

Conclusions: In conclusion, the i-STAT®1 produced comparable analytical results with an automated chemistry analyzer for glucose, creatinine and CO₂. Differences were observed for sodium, chloride and urea nitrogen. The i-STAT®1 was an effective tool in reducing costs, since samples were not sent to a referral laboratory for analysis, with associated delays in turnaround time. In addition, the analyzer was suitable for use with the relatively small batches of specimens typical of a postmortem forensic laboratory.

Key Words: Chemistry, i-STAT, Vitreous Humor

Screening and Confirmation of 29 Benzodiazepines and Hypnotics in Urine by LC-MS/MS**Hsiu-Chuan Liu**^{*1}, Hsin-Yun Luan¹, Ray H. Liu² and Dong-Liang Lin¹¹Department of Forensic Toxicology, Institute of Forensic Medicine, Ministry of Justice, Taipei, Taiwan; ²Department of Medical Laboratory Science and Biotechnology, Fooyin University, Kaohsiung, Taiwan

Objectives: Known for their sedative, hypnotic and anticonvulsant properties, benzodiazepines are among the most frequently prescribed drugs, mainly for treating anxiety and sleep disorders. This study evaluated whether postmortem urine specimens could effectively be analyzed by liquid chromatography-tandem mass spectrometry (LC-MS/MS) for the following 29 benzodiazepines and hypnotics: alprazolam, hydroxyalprazolam, bromazepam, brotizolam, chlordiazepoxide, clobazam, clonazepam, 7-aminoclonazepam, diazepam, estazolam, flunitrazepam, 7-aminoflunitrazepam, flurazepam, desalkylflurazepam, lometazepam, lorazepam, midazolam, hydroxymidazolam, nitrazepam, 7-aminonitrazepam, nordiazepam, oxazepam, prazepam, temazepam, triazolam, hydroxytriazolam, zaleplon, zopiclone and zolpidem.

Materials and Methods: Urine specimens (1 mL) were hydrolyzed with β -glucuronidase, extracted via liquid-liquid extraction, evaporated and reconstituted in mobile phase for injection onto the LC-MS/MS. Deuterated analyte analogues were used as internal standards. Chromatographic separation was achieved using an Agilent Zorbax SB-Aq (100 mm \times 2.1 mm i.d., 1.8- μ m particle) analytical column at 50 °C. The mobile phase consisted of 0.1% formic acid (v/v) in water (A) and methanol (B) at a flow rate of 0.32 mL/min. The initial gradient composition (A/B 90:10, v/v) was held for 1.5 min, decreased to 0% A in 8.5 min and held for 2 min, and increased to 90% A in 1 min and was held for 2 min. Mass spectrometric analysis was performed by electrospray ionization in positive-ion multiple reaction monitoring (MRM) mode with optimized collision energy for the precursor ion selected and two transitions per analyte were monitored.

Results: Validation was performed by extracting drug-free urine fortified with 20–400 ng/mL of the 29 analytes. Mean extraction efficiency (n=5) was >90%, except for brotizolam (mean \pm SD 88 \pm 13%), zaleplon (85 \pm 5.9%) and zopiclone (73 \pm 7.3%). Inter-day and intra-day imprecision (%CV) was 0.44–15% and 1.1–15%. Calibration linearity (r^2), detection limits, and quantification limits were >0.997, 1–2 ng/mL and 1–5 ng/mL, respectively. Ion suppression was <20% for all analytes except triazolam (31%), desalkylflurazepam (33%), diazepam (37%), brotizolam (40%) and prazepam (80%); use of deuterated internal standards compensated for ion suppression.

Conclusion: We conclude that this relatively simple procedure can be used for routine and reliable quantification of 29 benzodiazepines and hypnotics in urine.

Key Words: Benzodiazepines, LC-MS/MS, Urine

Acute Toxicity by Hair Dye in Upper Egypt**Hatem A. Ahmed**^{1*}, Ragaa M. Abdelmaaboud², and Manal M. S. El-Meligy²¹Laboratory of Justice, Assiut, Egypt; ²Department of Forensic Medicine and Clinical Toxicology and Anatomy, Faculty of Medicine University of Assiut, Egypt

Objectives: Hair dye containing *p*-phenylenediamine is widely used in the Middle East and some Asian countries. In these regions, there have been many reported cases of toxicity and mortality due to accidental or deliberate ingestion of hair dye. The aim of the present work was to 1) perform chemical analysis of the black hair dye by the use of scanning electron microscopy and TLC (thin layer chromatography) 2) to analyze the various aspects of acute poisoning through a retrospective study of fatalities reported in seven governorates in Upper in Egypt, and 3) to determine if there is a dose-effect relationship based on an acute toxicity study in rats.

Methods: Records of acute poisoning cases in seven governorates in Upper Egypt were investigated by Assiut Forensic Chemical Laboratory (AFCL) during the period of January 2002 to December 2008. The cases were examined regarding the type of poison, pattern, incidence, age, sex, geographical distribution and mode of poisoning. Separately, four groups of albino rats (each group containing 6 rats) were orally administered hair dye in different doses (500, 200, 100, and 50 mg/kg). The clinical symptoms of the animals were observed and sections of vital organs were histologically examined.

Results: About 20% of the acute poisoning fatalities investigated by AFCL were due to ingestion of hair dye. The majority were female suicide cases from Qena, Sohag and Aswan Governorates. Most were in the age group 31-40 years (38%), followed by 21-30 years (34%). In the animal studies, death occurred within 5 minutes, 10 minutes or 1 hour, respectively, for the rats receiving 500, 200, and 100 mg/kg doses. The animals of the fourth group (50 mg/Kg) survived until sacrificed after one week. The most common histopathological changes in the organs studied were vascular congestion and lymphocyte infiltration, with degenerative changes in the hepatocytes and destruction of the renal tubules.

Conclusions: Deliberate self-poisoning by hair dye is a major problem in Upper Egypt particularly in females. The toxic effects in rats were predominately in the liver and kidneys, while the other organs were only affected to a milder extent. Also, there was a well established dose-effect relationship in the rat.

Key Words: *p*-Phenylenediamine, Suicide, Egypt

Fatal Poisoning with *Aconitum Napellus*, Lethal Thyroid Storm or Both?

Thomas Keller^{*1}, Eva Maria Arlt¹, Wolfgang Bicker², Helmut Wittmann³ and Fabio Monticelli¹

¹Institute of Forensic Medicine, University of Salzburg, Ignaz-Harrer-Str. 79, 5020 Salzburg, Austria; ²FTC-Forensic Toxicological Laboratory Ltd., Simmeringer Hauptstr. 24, 1110 Vienna, Austria; ³Institute of Ecology, Abfalterhofweg 12, 5020 Salzburg, Austria

Case Report: We report the case of an 18-year-old girl who was found dead in the sleeping room of her father's apartment. According to police investigations, the deceased suffered from depression and anorexia nervosa. Due to the latter fact and because her sister was prescribed thyroid hormones, a potential self medication or misuse could not be ruled out. Furthermore, a glass with a brown liquid containing plant material was found at the death scene. A forensic autopsy was performed after discovery of the deceased; however, all autopsy findings were unremarkable. Routine toxicology screening resulted in no notable findings. Additional botanical analysis of the plant material demonstrated it to be *Aconitum napellus*, resulting in additional laboratory studies confirming the presence of aconitine in all postmortem specimens. Death in this case was attributed to *Aconitum napellus* ingestion.

Methods: Songorine, often found in ranunculaceae, was detected in the stomach content by gas chromatography mass spectrometry (GC/MS); therefore, targeted liquid chromatography tandem mass spectrometry (LC-MS/MS) in the selected reaction monitoring mode was performed for aconitine in all postmortem specimens and the brown liquid found at the death scene. Urine samples were diluted 1:100 with mobile phase, while liquid-liquid extraction was employed for other matrices (blood, bile, etc.) using mesaconitine as internal standard. Matrix-matched calibration from 5-1000 ng/mL (urine) and 5-640 ng/mL (human blank serum; calibration also used for other matrices) was carried out. Method validation included an evaluation of matrix effects, which were negligible for urine. Extended LC-MS/MS investigations identified aconitine-related alkaloids in the plant material, as well as in all the post-mortem specimens. The plant material in the brown liquid was morphologically identified by a botanist as from *Aconitum napellus* ssp. *hians*. Peripheral blood was also analyzed by immunoassay for the thyroid hormones free T3 (FT3), FT4 and thyroid stimulating hormone (TSH).

Results and Conclusions: Toxicological examination was carried out since the autopsy findings were unremarkable. No alcohol, drugs or pharmaceuticals were detected by general toxicological analysis at the time of death. The presence of aconitine was quantified in all postmortem specimens following the botanical determination of *Aconitum napellus* at the scene. Concentrations ranged from 15.4 ng/mL in peripheral blood to 609 ng/mL in stomach content. This allowed the establishment of the cause of death, as due to the ingestion of parts of *Aconitum napellus*. In addition, the peripheral blood revealed a substantial FT3 (10.6 ng/L) elevation and a dramatic TSH (0.01 μ U/mL) decrease; thus, the cause of death should be discussed in combination with hyperthyreosis factitia, maybe caused by self-medication with thyroid hormones.

Key Words: Aconitine, Thyroid Storm, Intoxication

Hydrogen Sulphide and Cocaine: A Lethal Cocktail

Verity Hayward¹, Kate Jones², **Jennifer Button**^{3*}, Sebastian Lucas⁴, Malgorzata Puchnarewicz¹ and David W Holt¹.

¹Analytical Unit, St. George's, University of London, UK; ² Health & Safety Laboratory, Derbyshire, UK; ³Forensic Science Service Ltd, Lambeth, London, UK; ⁴Dept of Histopathology, Guy's & St Thomas' NHS Foundation Trust, London, UK

Objective: We present a case of a fatality resulting from the toxicity of hydrogen sulphide (H₂S) in combination with cocaine. In June 2010, police attended a London property to check on the welfare of a 30 year old man. Upon gaining entry they discovered a deceased male in the bathroom. A strong smell of ammonia was present in the room; the bath contained two tubs of unknown substance and a bottle of unknown liquid. A white powder was also discovered. Specialist units determined that a lethal gas had been created by mixing a sulphur based product with battery acid. This was corroborated by post-mortem findings, including a green discolouration of the brain, consistent with H₂S exposure. Post-mortem peripheral blood and urine samples were submitted to the Analytical Unit for systematic toxicological analysis (STA), and aliquots were referred to the Health & Safety laboratory for analysis of thiosulphate, the major metabolite of H₂S.

Method: Thiosulphate calibrators were prepared in blood and urine over a range of 0 to 500µmol/L. Calibrator/sample (200µL) and internal standard, 10µM tribromobenzene (100µL), were derivatized using pentafluorobenzyl bromide and extracted into 2mL 25mM iodine ethyl acetate solution. 1µL was injected onto the GCMS system. A BP-5 equivalent GC column (30m x 0.32mm id, 1µm film) was used with helium as the carrier gas. The oven was held at 100°C for 2 minutes then ramped at 10°C/min. The principal ions monitored were m/z 426 for thiosulphate and m/z 314 for tribromobenzene.

Results: Thiosulphate was detected at a concentration of 64 µmol/L in blood and 2.7 mmol/mol creatinine in urine. The blood concentration was consistent with those seen in industrial fatalities (25-230 µmol/L). The major breakdown product of cocaine, benzoylecgonine, was detected at a concentration of 15 mg/L in blood and is consistent with concentrations seen in other fatalities (0.7-31 mg/L).

Conclusion: Following the results of scene investigation, post-mortem and toxicological analysis, HM Coroner ruled that 'The deceased took his own life by creating a deadly H₂S gas and taking a cocaine overdose'. This case is therefore an example of suicide by combined toxicity of H₂S and cocaine confirmed by toxicological analysis.

Key Words: H₂S, Thiosulphate, Post-Mortem

Postmortem Toxicological Investigation of Alcoholic Ketoacidosis**Ingrid J. Bosman*** and Rianne Vincenten

Netherlands Forensic Institute, Department of Forensic Medicine, Laan van Ypenburg 6, 2497 GB The Hague, The Netherlands

Introduction and Objectives: Ketoacidosis is a biochemical disturbance in the body. If no glucose is available, the body will utilize fatty acids as an alternative fuel pathway and ketone bodies (acetoacetate, acetone and betahydroxybutyrate (BHB)) will be produced. Two particular forms of ketoacidosis exist: alcoholic ketoacidosis as a result of chronic alcohol abuse and diabetic ketoacidosis as a result of a reduction in insulin. In contrast to diabetic ketoacidosis in which hyperglycemia occurs, alcohol ketoacidosis usually produces a hypoglycemia, although slight hyperglycemia can exist.

In this paper, the toxicological results of postmortem cases at the Netherlands Forensic Institute from January 2006 with no anatomical cause of death and the victim having a history of alcohol abuse were examined. The aim was to evaluate the importance of toxicological investigations for alcoholic ketoacidosis to provide a possible cause of death in such cases. Included were cases with no anatomical cause of death, the victims with a history of alcohol abuse, and toxicological analysis of BHB.

Materials and Methods: All cases were screened for the presence of ethanol (by HS-GC-FID) and drugs of abuse and prescription drugs (using SPE followed by GC-MS and LC-DAD). Enzymatic assays with spectrometric analysis were conducted for the determination of BHB, glucose and lactate. Six cases were included in the study: four males and two females with ages ranging between 39 and 62 years.

Results: At autopsy, the pathologist found no anatomical cause of death or clear cause of death. Toxicological analysis for the presence of ethanol, drugs of abuse and prescription drugs did not reveal a toxicological cause of death. Ethanol was detected in blood in three cases (0.03 to 1.8 g/L), in urine in four cases (0.06 to 2.4 g/L) and prescription drugs were found in four cases. Acetone was detected in blood and/or urine in all cases. Further analysis of BHB in blood, urine or vitreous humor was performed to determine possible ketoacidosis. Concentrations of glucose and lactate in blood, urine or vitreous humor were used to determine possible hypo- or hyperglycemia. Based on the combined glucose and lactate concentrations in vitreous humor, an indication of hypoglycemia was found in one case (measured concentration lower than 7.5 mmol/L) and hyperglycemia was found in another case (measured concentration was 30 mmol/L). Measured concentrations of BHB varied from 1 to 14 mmol/L in blood and from 1 to 11 mmol/L in vitreous humor. In literature, BHB concentrations are considered normal below 0.5 mmol/L, elevated up to 2.5 mmol/L, and high and pathologically significant over 2.5 mmol/L. The measured BHB concentrations in this study were all elevated or high. Overall, the pathologist concluded that death could be explained by alcoholic ketoacidosis in 5 cases and death due to a combination of ketoacidosis and hyperglycemia in one case.

Conclusions: In conclusion, in cases with no anatomical and toxicological cause of death, a history of alcohol abuse, and the presence of acetone in blood or urine, analysis of BHB in blood and vitreous humor may provide a possible cause of death due to alcoholic ketoacidosis.

Key Words: Alcoholic Ketoacidosis, Betahydroxybutyrate, Postmortem

Suicide by Asphyxiation Due to Helium and Argon

Frank Musshoff* and Burkhard Madea

Institute of Forensic Medicine, University Hospital, Bonn, Germany.

Objectives: Numerous death cases due to suffocation in a toxic or oxygen deficient gas atmosphere have been described in the literature, but unfortunately cases involving inert gases like helium are often presented without detailed toxicological findings. We report observations from two suicide cases, one by helium and the other by argon inhalation.

Materials and Methods: During autopsy, gas samples from the lungs were collected directly into headspace vials by a procedure ensuring minimal loss and dilution. Qualitative gas analyses were performed using gas chromatography mass spectrometry (GC–MS) in split mode (HP 5890 GC/5970 MSD, split ratio 3:1, flow 1 mL/min, injector temperature 100 °C, oven: 120 °C isothermal, interface temperature 200 °C, SIM: $m/z = 4, 16, 18, 32, 40, 44$) and a headspace (HS) syringe (manual injection, injection volume 500 μ L). An Optima-1 MS (Macherey-Nagel, Dueren, Germany; i.d. 0.25 mm, film thickness 0.25 μ m, $l = 25$ m) GC column was used. Helium carrier gas was replaced by nitrogen.

Results: Qualitative positive results were obtained in the argon case, but in the case involving helium, we observed peaks similar to those revealed from environmental air.

Conclusion: HS-GC/MS enables the detection of inert gases like argon or helium. However, many factors may later influence interpretation of analytical results, e.g. a longer period of time between death and sampling or pre-analytical artefacts during sampling of such highly volatile substances. In the present cases in absence of analytical data supporting helium exposure, the cause of death was found to be asphyxia and in both cases the manner was suicide.

Key Words: Helium, Argon, HS-GC/MS, Suicide

Preliminary Analysis of Distribution of Sulfonylureas in Tissues of Poisoned Animals

Mareta Mukharbekovna Ibragimova*

Forensic-Medical Bureau of Tashkent City, Tashkent, Uzbekistan

Objective: Sulfonylureas are widely used in the treatment of type 2 diabetes mellitus and may be of forensic and clinical toxicology relevance. Sulfonylureas of interest include: glibenclamide, gliclazide, glipizide, glimepiride and glicvidone. Sulfonylureas intoxication is an effect of overdose, abuse and hypersensitization. Current literature lacks data regarding the distribution of sulfonylureas in organs and biological fluids of people and animals. Therefore, it is difficult to choose which biological specimens to analyze for sulfonylureas. The aim of this research was to investigate the distribution of the listed antidiabetic drugs in different tissues of animals after oral administration.

Materials and Methods: Our investigation focused on internal organs and biological fluids (blood and urine) of laboratory rabbits. Varying amounts (30-300 mg/kg) of the sulfonylureas were administered to animals by ingestion with food. The animals were killed by air embolism 2-3 hours after ingestion. Stomach contents, thin and thick intestines, liver, kidneys, lungs, heart, blood and urine were collected post mortem (when little urine was available, the bladder was removed). Analysis of the internal organs involved isolation of sulfonylureas with acetone and extraction with chloroform. Sulfonylureas in urine were extracted with chloroform after acidification. Extraction from blood involved alkaline hydrolysis. Biological samples were analyzed by thin-layer chromatography, UV- spectrophotometry, and high performance liquid chromatography (HPLC). The HPLC detection limit was 0.05 µg/mL. Chromatographic conditions included a 4.6 x 250 mm XP-18 5µm column, a spectrophotometric detector operating a 190-600 nm, an injection volume of 20 µL, and oven temperature of 40°C. Mobile phase and detection wavelength were different for each drug.

Results: Results of the experiments are given in the table below. The largest quantities of sulfonylureas were found in liver, kidney, stomach, blood and urine. Smaller quantities of sulfonylureas were found in intestines, lungs and heart.

Substances	Quantities Administered (mg/kg)	Concentrations (mg/g or mg/mL)				
		Liver	Kidney	Stomach	Blood	Urine
Glibenclamide	41.7 - 55.6	0.23 - 0.36	0.17 - 0.23	0.09 - 0.13	0.09 - 0.17	0.06 - 0.13
Gliclazide	276.0 - 308.0	1.70 - 2.00	0.62 - 1.10	0.17 - 0.28	0.30 - 0.40	0.21 - 0.38
Glipizide	23.8 - 33.3	0.15 - 0.20	0.10 - 0.15	0.05 - 0.07	0.03 - 0.10	0.04 - 0.08
Glimepiride	18.5 - 30.0	0.10 - 0.21	0.09 - 0.15	0.03 - 0.06	0.05 - 0.10	0.05 - 0.10
Glicvidone	53.6 - 68.2	0.28 - 0.31	0.06 - 0.11	0.08 - 0.11	0.18 - 0.22	0.04 - 0.05

Conclusions: This research will aid investigators in selecting of the appropriate biological specimen for analysis of sulfonylureas in poisoning cases.

Key Words: Sulfonylurea, Tissue Distribution, HPLC

Postmortem Drug Concentration Ranges in Blood for the Non-Intoxicated State Compared to Commonly Cited Therapeutic Ranges in Serum

Kristian Linnet*

Section of Forensic Chemistry, Dept. of Forensic Medicine, Faculty of Health Sciences, University of Copenhagen, Denmark

Introduction and Objectives: In postmortem toxicology it is important to know the normal drug concentrations found in blood in order to make interpretations with regard to the possibility of intoxication. Commonly, plasma or serum concentrations observed in vivo under therapeutic circumstances or in pharmacokinetic studies are used as reference concentrations. For example, the therapeutic drug ranges found in commonly used hand books and displayed in the TIAFT therapeutic and toxic drug concentrations list are usually serum concentrations. By referring to in vivo conditions, the phenomenon of postmortem redistribution is not taken into account. Additionally, a possible discrepancy between plasma/serum and whole blood concentrations and differences between trough and peak values are not considered. In a few compilations and some specific drug studies, postmortem drug concentrations have been provided for the therapeutic situation, or more precisely, the presumed non-intoxicated state. In this study, published postmortem-derived blood drug reference concentration ranges were compared to therapeutic serum levels of drugs from the TIAFT list in order to assess agreement or discrepancies.

Method: A literature search was undertaken of publications presenting postmortem derived drug reference ranges in blood. These were compared to serum concentrations of therapeutic and toxic drugs from the TIAFT list. The ratios between the upper limits were evaluated.

Results: The ratios between postmortem concentrations to the upper reference limits from the TIAFT list ranged from 0.13 to 13.3 for 61 compounds with a median value of 1.3. For more than 40% of the compounds the ratio exceeded two. For highly water soluble drugs with a low propensity for redistribution, the ratios were generally low. For example, ratios for pentobarbital, phenobarbital, carisoprodol, meprobamate, carbamazepine, phenazone and theophylline, ranged from 0.14 to 1.1 with a median of 0.43. In contrast, for the 14 antidepressants considered, the ratio was relatively high, ranging from 0.6 to 7.0 (median 3.3). For antipsychotics, the ratios ranged from 0.2 to 11.3 with a median of 0.7.

Conclusion: There were wide discrepancies between serum based reference ranges presented in the TIAFT list and published postmortem blood reference ranges. Ultimately, more data on postmortem drug blood ranges is required to establish a reliable database for use by the forensic community.

Key Words: Postmortem, Reference Ranges, Toxicology

The Role of Methadone in Drug Related Deaths: the Italian Experience 2000-2010

Nadia De Giovanni, **Nadia Fucci***, and Remo Marsili

Institute of Legal Medicine- Catholic University, L.go F.Vito 1-00168, Rome, Italy

Objective: The purpose of this study was to report methadone related death trends in an Italian community. Methadone is an orally active μ -opioid receptor agonist used in the treatment of opioid dependent persons such as chronic heroin users. Although in recent years buprenorphine (a partial μ -opioid receptor agonist employed as a narcotic analgesic for the treatment of moderate-to-severe pain) has been introduced in Italy as an opiate substitute for treatment of heroin dependence, methadone is still utilized. A significant number of methadone related deaths are documented in the international scientific literature although its role in lethal intoxications has not been completely clarified.

Materials and Methods: We evaluated methadone related death toxicology data from 2000 to 2010 at the Institute of Legal Medicine of the Catholic University of Rome. During this period the laboratory examined 4000 corpses associated with violent death. Approximately 17% were submitted to full toxicological analysis as requested by the Court, and methadone was identified in 45 corpses. The majority of deaths were attributable to methadone alone or in association with other drugs (such as morphine, ethanol, and cocaine). A gas chromatographic/mass spectrometric analysis (GC/MS) was performed on blood samples using pre-validated in-house methods that employ and internal deuterated standard.

Results and Conclusion: When the corpse displayed no trauma or signs of violence and methadone was the only compound found in the toxicological analysis ($n = 10$), a range of concentrations between 100 to 3000 ng/mL was detected, indicating that toxic methadone concentrations overlap with non-toxic values. Moreover methadone was found in association with other illicit drugs such as morphine ($n = 10$) and ethanol ($n = 12$) combined with cocaine or morphine. These observations suggest the need to monitor therapy and /or the abuse of methadone.

Key Words: Methadone, Postmortem, Drugs of Abuse

Pilot Study: In Vitro Metabolic Effects of *Escherichia Coli* on Cocaine and FentanylStephanie Martindale*¹, Suzanne Bell¹, and Sue Bae²¹West Virginia University, Morgantown, WV, USA; ²Edgewood Chemical Biological Center at Aberdeen Proving Grounds, Gunpowder, MD, USA

Introduction and Objectives: Anaerobic bacteria and microbes native to the human body are active in the post-mortem decomposition process, especially during the putrefaction and decaying phases. After death, these species may cause biotransformations that affect the ratio of compound to metabolite concentration within the human body. To date, such post-mortem changes are rarely considered and this may be leading to discrepancies in compound identification which could influence information concerning time-since-death estimations. This research aims to explore the potential of using enteric bacterial species in order to determine whether such biotransformations occur, how they occur, to analyze the types of anaerobic bacterial metabolites produced, and to compare these metabolites to those produced by normal human metabolism. The purpose of this study was to establish protocol for growing, inoculating, and dosing the bacteria and to design a qualitative detection method for the bacterial metabolites of interest.

Materials and Methods: These experiments focused on *Escherichia coli*, a Gram-negative, facultative anaerobe, which is native to and prevalent in the intestinal tract. In addition, two drugs of forensic importance (and their metabolites) were chosen as the compounds of interest, which include cocaine (benzoylecgonine, cocaethylene, ecgonine methyl ester, *m*-hydroxybenzoylecgonine, norbenzoylecgonine, norcocaine) and fentanyl (norfentanyl). The bacteria were grown under anaerobic conditions using the GasPak Pouch® System with GasPak EZ Anaerobe Pouch inserts. Single, pure colonies were isolated on the agar plates and used in the inoculation of the designed media broth for the metabolic analysis studies. The media was composed of Bacto Tryptone and Yeast Extract and was buffered at a pH of 7.4. Broth samples were spiked with one of the selected drugs, inoculated with a single bacterial species, and incubated for 24 hours at 37°C. Samples were extracted from the media and analyzed using the Agilent 6460 Triple Quad LC/MS/MS System. Chromatographic separation of the drugs and metabolites was achieved using an Atlantis HILIC Silica (3µm particle size, 2.1 x 50mm) column, and the mass spectrometer was operated in positive mode with electrospray ionization. A qualitative method was established for each drug and its respective metabolites using a 0.1 µg/L standard drug solution. Analytes were detected via the following characteristic MRM transitions: cocaine (304.1, 182.1, 150.1, 82.1); benzoylecgonine (290.1, 168.1, 150.0, 82.1); cocaethylene (318.0, 196.1, 150.1), ecgonine methyl ester (200.2, 182.1), *m*-hydroxybenzoylecgonine (306.1, 168.0), norbenzoylecgonine (276.1, 154.0), norcocaine (290.3, 168.1), fentanyl (337.0, 188.4), and norfentanyl (233.0, 84.3). Cocaine D₃ and fentanyl D₅ were used as internal standards.

Results and Discussion: The use of anaerobic bacteria native to the human body and their role in anaerobic biotransformations and metabolism has not, to our knowledge, been investigated. We recognize that the actual decomposition process is chaotic and each case unique, however, the goal is to start simply and then expand upon that base of knowledge. In the future, we aim to quantify the drug compound to bacterial metabolites, validate the method, and extend this technique to explore other homeland security threats including additional drugs of abuse, chemical warfare agents, and explosives.

Key Words: Bacteria, Metabolism, LC/MS

Analysis of Cyanide in Biological Specimens: A Comparison Between a Color Test and a Validated Headspace Gas Chromatography Method and its Application in a Fatal Intoxication Case

Fabrcio Souza Pelicão*^{1,2}; Daniela Mendes Louzada de Paula²; Jauber Fornaciari Pissinate²; Josidéia Barreto Mendonça² and Bruno Spinosa De Martinis³

¹Faculty of Pharmaceutical Sciences of Ribeirao Preto - University of Sao Paulo, SP, Brazil; ²Police of Espirito Santo, Laboratory of Forensic Toxicology, Vitoria, ES, Brazil; ³Department of Chemistry, Faculty of Philosophy, Science and Literature of Ribeirão Preto, University of São Paulo, Brazil

Objective: We propose a simple color test as screening procedure for cyanide detection and verify its applicability to different biological matrices in a case of fatal intoxication (suicide). We also compare the results from the color test with those obtained by headspace gas chromatography in specimens from a fatal intoxication case.

Materials and Methods: Color screening test - 0.5 mL of blank blood was fortified with cyanide working solutions in test tubes to obtain concentrations of 0.05 - 10.0 µg/mL. Blood, urine and stomach contents from a fatal intoxication case (0.5 mL) were also analyzed. Chloroform and sulfuric acid (50 µL each) were added to each specimen to form hydrogen cyanide (HCN). Immediately after acid addition, a piece of filter paper, impregnated with the color reagent (sodium bicarbonate and picric acid in water), was placed into the test tubes, and the contents were heated to 30°C for 1 h. The HCN formed in the tube changes the yellow color of the filter paper from orange to brown–orange and then to orange–red or red. **Confirmatory method** – 0.5 mL of blank blood was placed in a headspace vial and fortified with cyanide working solutions to obtain concentrations of 0.05 - 4.0 µg/mL. Blood, urine and stomach contents of a fatal intoxication case (0.5 mL) were also added. Then, 0.5 mL of acetonitrile internal standard was added to each sample. Lastly, 50 µL of sulfuric acid was added and the vials were immediately capped. Samples were analyzed by a headspace gas chromatograph equipped with a Thermionic Specific Detector (HS-GC/TSD).

Results: The color screening test showed a limit of detection of 2.0 µg/mL. The color tests for blood and stomach contents from the fatal intoxication case were positive, even at a 1:10 dilution. However, the urine specimen tested negative due to low urine cyanide concentrations following acute intoxication. Linearity study for the HS-GC/TSD method was done using six calibrators (0.1 to 4.0 µg/mL) and six replicates at each concentration (n = 36). A correlation coefficient (r^2) of 0.9984 was obtained. The study of accuracy and imprecision was carried out over a period of three days at three concentrations (0.1, 0.7, and 3.0 µg /mL) and five replicates of each concentration (n = 15 per QC). The resulting intra-day imprecision (CV%) was 8.6% and the inter-day was 4.3%. Intra-day inaccuracy (RSD%) was 8% and the inter-day was 12.8%. Cyanide quantified at 30.7 µg/mL in blood, 100.5 µg/mL in the stomach contents and 0.1 µg/mL in the urine from the intoxication case.

Conclusion: Laboratory screening and confirmation of cyanide provided acceptable results in this case. Color tests are a useful tool to laboratories that do not have sophisticated equipment to allow for a screening search for cyanide in acute intoxication cases.

Key Words: Cyanide, Suicide, Color Test

Liquid Chromatography/Time-of-Flight Mass Spectrometry Analysis on Post-Mortem Blood Samples for Targeted Toxicological Screening

Markus Roman, Lena Ström, Helena Tell and **Martin Josefsson***

Dept Forensic Genetics and Forensic Toxicology, National Board of Forensic Medicine, Linköping Sweden

Objectives: A method for targeted toxicological screening in human blood samples from forensic autopsy cases has been developed and validated. The aim was to replace an existing drug screening utilizing gas chromatography with nitrogen phosphorus detection (GC-NPD) with a weekly turnover of approximately 100-150 samples.

Materials and Methods: Analysis was performed on an Agilent 6540 quadrupole time-of-flight mass spectrometry (Q-TOF) instrument equipped with a Jet Stream interface in combination with an Agilent 1290 Infinity LC instrument. Separation was achieved within 12 minutes, at a 0.5 mL/min flow rate, by gradient chromatography on a Waters Acquity HSS T3 (2.1x150 mm, 1.8 μ m). Mobile phase A consisted of 0.05% formic acid in 10 mM ammonium formate and mobile phase B consisted of 0.05% formic acid in acetonitrile. Ions were generated in positive electrospray ionization mode. Samples were detected at 2 GHz single MS mode, m/z range 50-1000 with a scan rate of 1.5 spectra/sec. For internal mass calibration two reference masses were constantly infused into the ion source performing mass correction in every single scan. Before injection 0.25 g blood was prepared by protein precipitation with 500 μ L of a mixture of acetonitrile and ethanol containing deuterated internal standards. Data were acquired and processed with MassHunter B.04.00 software. Validation was performed on spiked blood samples and authentic autopsy cases. An in-house database comprising nearly 500 drugs and metabolites was built by analyzing solutions from certified standards or other documented reference material available. Data were extracted by the "find by formula" (FBF) algorithm with match tolerances for mass accuracy of ± 10 ppm, retention time deviation ± 0.15 min and area of ≥ 30000 counts. Identification was based on scoring of retention time, accurate mass measurement and isotopic pattern. The minimum required performance levels (MRPL) based on toxicity and expected concentrations were for most compounds in the range of 0.01-0.10 μ g/g. Typically a mass accuracy of < 2 ppm and imprecision of area measurements of $< 5\%$ (CV) was achieved when MRPL were tested by injection of spiked replicates of each compound (n=5). For studies on matrix effects different autopsy blood samples were spiked.

Results: Positive identification was confirmed at concentrations up to 100 μ g/g. The majority of the compounds were determined by positive ionisation. For a limited number of compounds ($< 4\%$) negative ionisation was needed and a few (n=5) early-eluting compounds (< 1.5 min) could not be identified due to substantial influence of interferences from the matrix. A limited number (n=13) of critical pairs of unresolved compounds with identical formula and masses were identified. However, these analytes could be differentiated by their fragment ions after re-injection for an additional MS/MS mode analysis.

Conclusion: A drug screening assay for autopsy blood samples with higher precision and sensitivity than the previously used GC-NPD assay was achieved. The method cannot be considered general since some drug classes are detected only in negative mode (e.g., barbiturates, salicylic acid) and in addition a few important drugs are not detected under their optimal conditions with the method parameters used (e.g., GHB, THC). However, the same extract can be used for additional injections. Thus, a combination of LC-TOF methods can be used.

Key Words: Autopsy, Blood, Liquid Chromatography, Mass Spectrometry, LC-TOF

Use and limitation of models for microbial ethanol production in post-mortem cases

Vassiliki A. Boumba*¹, Nikolaos Kourkoumelis², Theodore Vougiouklakis¹

Departments of ¹Forensic Medicine & Toxicology; and ²Medical Physics, Medical School, University of Ioannina, 45110 Ioannina, Greece

Objective: In a previous study, we developed simple mathematical models to approximate microbially produced ethanol in correlation with other alcohols for *C. perfringens*, *C. sporogenes* and *E. coli*. The objective of this study was to test the applicability of these models in real post-mortem cases.

Materials and Methods: Six years of archived chromatograms were reviewed retrospectively with 40 postmortem cases selected for having other alcohols detected during the original blood forensic ethanol analysis. The concentration of the higher alcohols (1-propanol, isobutanol, 2-methyl-3-butanol and 2-methyl-1-butanol) and 1-butanol were calculated in each case. The six models developed previously [Boumba et al., 2011; doi:10.1016/j.forsciint.2011.03.003] were applied to calculate ethanol concentrations for each case. Standard errors produced for each case after comparing the original ethanol concentrations measured for each case and the calculated concentrations after applying each model were used to evaluate the applicability of the models.

Results: The models corresponding to *C. perfringens* estimated microbially produced ethanol with a standard error <40% for 27 out of the 40 cases (68%) with 26 of the 27 cases (96%) having marked signs of putrefaction. Additionally, 21 of these cases (78%) had an ethanol concentration less than 0.7 g/L. The models corresponding to *E. coli* estimated the microbial produced ethanol with a standard error <40% for 25 out of the 40 cases (63%) with 24 showing marked signs of putrefaction (96%). Eighteen of these cases (72%) had ethanol concentration less than 0.7 g/L. The models corresponding to *C. sporogenes* estimated the microbial produced ethanol with an error <40% for 18 out of the 40 cases (45%) with all cases presenting with putrefaction at autopsy. Twelve of these cases (67%) had ethanol concentrations less than 0.7 g/L. It is worth noting that 28 out of 29 cases (97%) had original ethanol concentrations lower than 0.7 g/L with a standard error <40% in predicting microbially produced ethanol by at least one of the three models.

The application of the models appears to be limited in post-mortem cases where part or all of the detected blood ethanol is of ante mortem origin. Furthermore, in cases where other microbes have been activated in post-mortem blood samples it is possible that different models, not yet developed, are needed to estimate the microbially produced ethanol.

Conclusions: The model for *C. perfringens* has better applicability than *E. coli* or *C. sporogenes* in post-mortem cases. All models are more effective when marked putrefaction is present and when blood ethanol concentrations are less than 0.7 g/L.

Key Words: Post-Mortem Blood, Microbial Ethanol; Model

Fatal Mephedrone Intoxication – A Case Report

Piotr Adamowicz¹, **Bogdan Tokarczyk***¹, Roman Stanaszek¹, Markus Slopianka²

¹Institute of Forensic Research, Krakow, Poland; ²Hochschule Fresenius, Idstein, Germany.

Case History: A young male was found in a critical state in a staircase. Despite attempts of resuscitation carried out by two ambulance teams, the man died. Eight plastic bags containing 8 g of white powder were found in the pocket of the deceased. Colorimetric spot tests carried out by the police indicated presence of 2C-B (4-bromo-2,5-dimethoxyphenethylamine) in the powders. Blood and vitreous humor specimens were delivered to the Institute of Forensic Research (IFR) for confirmatory toxicological analysis for 2C-B.

Materials and Methods: Routine screening analyses carried out by gas chromatography (GC, Thermo Focus GC), gas chromatography with mass spectrometry (GC-MS, Finnigan Thermo Ultra/Polaris Q), high pressure liquid chromatography with diode array detection (HPLC-DAD, Hitachi LaChrom Elite) and liquid chromatography with mass spectrometry (LC-MS, Agilent Technologies 1100 Series) did not reveal any positive results, therefore 2C-B in biological material was excluded. Laboratory requests for delivering the secured powders were not fulfilled at that point.

After five months, the powders were sent to the IFR. Analyses of this material were carried out using an Agilent Technologies 5973 GC-MS, a Merck/Hitachi D-7000 System HPLC-DAD and an Agilent Technologies 6520 Accurate-Mass Q-TOF LC-MS. Mephedrone (4-methylmethcathinone) of 80.4-87.3% purity was found in all powder samples.

In connection with these findings, the blood and vitreous humor samples (0.2 mL) were analyzed for the presence of mephedrone. The analytes were isolated by addition of mephedrone-d3 as internal standard to the sample and acetonitrile precipitation. Acetonitrile was evaporated and reconstituted in 0.1% (v/v) formic acid in water. Analyses were carried out using an Agilent Technologies 6460 Triple Quad LC-MS. Separation was performed on a Zorbax SB-C18 (2.1x50 mm, 1.8 µm particle size) column using gradient elution of 0.1% (v/v) formic acid in water and acetonitrile. Multiple reaction monitoring (MRM) with positive ion detection was used. The precursor ions and three fragment ions for each compound were selected as qualifiers and quantifiers for mephedrone: 178.1→160.1, 178.1→145.1, 178.1→77.1, and for mephedrone-d3: 181.1→163.1, 181.1→148.1, 181.1→91.1.

Results and Discussion: Mephedrone was found in the blood and in the vitreous humor at concentrations of 5.5 and 7.1 µg/mL, respectively, confirming that this was a fatal mephedrone intoxication. Mephedrone is a designer drug that has been reported in the past two years to cause fatalities and intoxications in users of 'legal highs'. The blood concentration of mephedrone determined in our case was similar to those found in fatalities reported in the literature [1]. It can be concluded that even for non-biological materials, specific methods should be used and both biological and non-biological materials from one case should be analyzed in one institution.

References:

1. P.D. Maskell, G. De Paoli, C. Senevirante, D.J. Pounder. Mephedrone (4-methylmethcathinone)-Related Deaths. *J. Anal. Toxicol.* 35: 188-191 (2011).

Key Words: Mephedrone, Intoxication, LC-MS/MS

Investigations of Codeine-Related Deaths Should Include Concentrations of Morphine and the Morphine Metabolites M3G and M6G

Joachim Frost*^{1,2}, Arne Helland¹, Andreas A. Westin¹, Ivar S. Nordrum^{1,2}, Lars Slørdal^{1,2}

¹St Olav University Hospital, Trondheim, Norway; ²Norwegian University of Science and Technology, Trondheim, Norway

Objective: Codeine, usually in combination preparations with paracetamol, is widely prescribed in Norway. Compared to morphine, it has low affinity to opioid μ -receptors, and its analgesic (and, presumably, toxic) effects are largely dependent on metabolic conversion to morphine by the polymorphic cytochrome P450 isoenzyme 2D6 (CYP2D6). On average, approximately 10% of a codeine dose is metabolised to morphine. However, reference literature on codeine-related toxicity report only codeine levels. A previous abstract from our laboratory (TIAFT 2008) is extended in the current investigation of codeine-related deaths in four Norwegian counties (total population approx. 850,000) over an eight-year period.

Materials and Methods: A total of 1,444 consecutive forensic postmortem toxicological cases were analysed in our laboratory from January 2003 to January 2011. Among these, 111 cases with detectable amounts of codeine in blood were identified, of which 34 had blood concentrations above the lower threshold for toxicity according to TIAFT criteria (0.3 mg/L). Autopsy records of these 34 cases were obtained and reviewed. CYP2D6 genotyping was performed.

Results: In the 34 cases singled out for review, femoral blood codeine concentrations ranged from 0.30 to 15.0 mg/L. Morphine concentrations ranged from not detectable (n/d) to 3.1 mg/L, and the active metabolite morphine-6-glucuronide (M6G) and the inactive metabolite morphine-3-glucuronide (M3G) were measured in concentrations ranging from n/d to 0.55 mg/L and 1.5 mg/L, respectively. The morphine to codeine concentration ratios averaged 0.05 and ranged from 0 (morphine n/d) to 0.39. Various other drugs and/or ethanol were detected in all cases. Paracetamol was found in 33 of 34 cases, indicating ingestion of paracetamol-codeine combinations. From the 34 cases, 4 deaths (12%) were attributed to codeine intoxication, 18 deaths (53%) to intoxication with multiple substances including codeine, and 12 deaths (35%) to other causes. Among 13 cases with potentially lethal codeine concentrations (>1.6 mg/L), 3 deaths were attributed to codeine intoxication, 8 to intoxication with multiple substances including codeine, and 2 to other causes. In 13 deaths following mixed intoxications where codeine was among the drugs present, morphine was not detected (2 cases) or found in low concentrations usually not associated with toxic effects (11 cases). CYP2D6 genotyping was available in 32 of the 34 cases singled out for review.

Conclusion: Our findings suggest a large variability in the amount of morphine present after codeine intake in forensic autopsy cases. This represents an interpretational challenge not properly addressed in the current literature. Whereas a significant amount of data suggests that bioconversion of codeine to morphine is essential for codeine-induced analgesia, this is not reflected in the reporting of overdose cases. Investigations of codeine-related deaths should include concentrations of morphine and the morphine metabolites M3G and M6G. CYP2D6 genotyping may be of interest in selected cases.

Key Words: Codeine, Forensic, Toxicology

Buprenorphine Related Deaths. Interpretation of Post-Mortem Blood and Urine Levels

Tor Seldén*^{1,3}, Johan Ahlner^{1,3}, Henrik Druid^{1,2}, Robert Kronstrand^{1,3}

¹National Board of Forensic Medicine, Linköping, Sweden, ²Karolinska Institutet, Department of Oncology-Pathology, Stockholm, Sweden; ³Department of Medical and Health Sciences, Linköping University, Sweden.

Objectives: The aims of this study were to closely investigate deaths involving Buprenorphine (Bup) to evaluate the role of Bup and its metabolite Norbuprenorphine (Nbup) including concurrent drugs, and to compare blood and urine Bup concentrations in different groups of cases.

Materials and Methods: From July 2005 to September 2009, all autopsy cases (N=97, 87 male) where Bup or Nbup was detected in femoral blood and where analysis of Bup was performed in urine were selected. Data from the postmortem examination and toxicology were compiled and cases were classified as follows: **Intoxication** (N=41) - circumstances indicated acute intake of Bup and no other competing cause of death was found. Alternatively, circumstances and autopsy findings indicated an opioid overdose (including froth in airways) and Bup was the only opioid drug detected. **Possible** (N=24) - circumstances and medico-legal investigation indicate an overdose, and Bup is likely to have caused or contributed to the fatal outcome, but other drugs or conditions may have been just as important. **Control** (N=14) - the cause of death was with certainty not due to Bup overdose. **Unclear** (N=18) - Circumstantial and background information insufficient for classification. Analysis was performed using SPE and LC-MS-MS. Urine samples were hydrolyzed before analysis.

Results: Results from buprenorphine measure-ments are presented in the table. There was no significant difference in blood concentrations of Bup and Nbup between the C group and the other groups. However, the ratio of Nbup/Bup was significantly lower in the I group compared with the C group for both blood and urine. In addition to Bup, other hypnotic and sedative drugs were found in >75% of the cases in the I, P, U groups, but in only 50% of the C-group. Lung edema and froth in airways were frequent and often prominent findings in the I and P groups, and less frequent in the other groups. Almost all cases in the I and P groups lacked major pathological changes, and in most I cases, the concentrations of concomitant drugs were low.

	I	P	C	U
B-Bup	0.8	1.0	2.7	0.4
B-Nbup	1.1	1.3	6.6	0.9
B-Nbup/Bup	0.6	0.9	1.9	2.1
U-Bup	49	29	33	13
U-Nbup	17	42	66	48
U-Nbup/Bup	0.2	1.3	2.9	3.2

Median blood (ng/g) and urine (ng/mL) concentrations and Nbup/Bup ratios.

Conclusion: Our data strongly suggest that a threshold discriminating between non-toxic and toxic blood concentrations for buprenorphine cannot be defined for postmortem cases. However, the lower Nbup/Bup ratios in both blood and urine indicate an acute intake, rather than chronic intake or acute upon chronic dose. We hypothesize that the lack or loss of tolerance to buprenorphine makes the difference, and that the Nbup/Bup ratios, therefore, should be calculated for both blood and urine and used as support for the diagnosis of acute buprenorphine intoxication. Conversely, the detection of high concentrations of norbuprenorphine in blood, and particularly in urine, makes an acute buprenorphine intoxication unlikely.

Key Words: Buprenorphine, Toxicity, Post-Mortem Toxicology

Suicide With bk-MBDB (Butylone): Clinical and Toxicological Findings

Malgorzata Klys*, Sebastian Rojek, Marcin Strona, Karol Kula, and Ewa Rzepecka-Woźniak
Department of Forensic Medicine Jagiellonian University School of Medicine, Kraków, Poland

Objectives: “Legal highs” are products containing psychoactive substances, such as cathinones, piperazines and synthetic cannabinoids, are abused by adolescents in Poland as alternatives to classic drugs like amphetamines or marijuana. Some of these substances have been controlled in keeping with Poland’s prevention of narcotic substances abuse since 2010; however, the majority of these potentially dangerous substances are still legal. The easy availability of “legal highs” are associated with a risk of severe poisoning or even death, and provide new challenges in clinical and forensic toxicological practice. We present a case of a suicidal 21-year old male who ingested a specified dose of a preparation called “Amphi-bi-a” that contains bk-MBDB, a β -ketone analog of MBDB (methylbenzodioxolylbutanamine; psychoactive stimulant chemically similar to MDMA) bought from a “smart shop”. Like MBDB, bk-MBDB may exert a stimulatory effect on the central nervous system and also have hallucinogenic potency.

Methods: Femoral blood and liver were collected from the decedent at autopsy, which was carried out within 24 h after death. Toxicological evaluation included LC-ESI-MS-MS analysis of the blood (1 mL) and liver (1 g) samples after solid – phase extraction using 6 mL LiChrolut C18-RP cartridges. A 6410 triple quadrupole mass spectrometer attached to a 1200 liquid chromatograph (Agilent) was employed for instrumental analyses. The chromatographic separation was performed on an Allure PFP column (50 x 2.1 mm, 5 micron, Restek). The mobile phases were: (A) water with 0.02% formic acid and 0.002 M ammonium formate and (B) acetonitrile with 0.02% formic acid and 0.002 M ammonium formate. The gradient started with 10% solvent B at a flow rate 0.5 mL/min and increased within 10 min to 90% at a flow rate of 1 mL/min, which was held for 5 min. The following transition ions m/z were monitored: 222.1/174.1 and 222.1/204.1 for bk-MBDB and 227.2/209.1 and 227.2/179.1 for bk-MDEA- d_3 (internal standard). Standard curves for bk-MBDB (0.005 – 2 mg/L) in blood and (0.05 - 5 mg/kg) in liver had correlation coefficients of 0.999. All precision and accuracy values were within acceptable limits. Histopathology exams were conducted on formalin-fixed and hematoxylin and eosin-stained sections of internal organs (heart, brain, liver, kidney, pancreas, spleen).

Results: The analysis of the case included a clinical assessment of the patient's health status performed during his 3 h hospitalization, in which tachycardia, hypersalivation, dilated pupils, seizures, hyperthermia, hemorrhagic diathesis and in consequence, cardiac arrest were reported. The autopsy demonstrated petechiae in the skin, massive pulmonary edema, blended cardiac muscle echymosis and additionally numerous disseminated systolic nodes. Toxicology showed the presence of bk-MBDB at 20 mg/L in the blood and 33 mg/kg in the liver.

Conclusions: The toxicology results demonstrate a causal relationship with the clinical presentation prior to death and the postmortem macro- and microscopic changes. In addition, this is our first documented poisoning case with bk-MBDB.

Key Words: bk-MBDB, Postmortem, LC-ESI-MS-MS

The Distribution of Doxepin and Sulpiride in a Human Poisoning Death

Zhiwen Wei*, Keming Yun and Yujin Wang

School of Forensic Medicine, Shanxi Medical University, 56 Xinjian South Road, Taiyuan 030001, China

Objectives: An unusual case is reported in which death was caused by doxepin and sulpiride toxicity.

Case Report: A 47-year-old woman committed suicide by oral ingestion of excessive doxepin and sulpiride. Histological examination revealed generalized stasis and we observed bronchopneumonia and chronic thyroiditis. Toxicological analyses by liquid-liquid extraction, gas chromatography-mass spectrometry (GC/MS) and liquid chromatography (LC) analysis were carried out to identify and quantify the individual substances present in postmortem specimens. Doxepin concentrations were as follows: heart blood 16.3 µg/mL, subclavian vein blood 9.4 µg/mL, bile 15.8 µg/mL, gall bladder 4.4 µg/g, heart 3.9 µg/g, liver 75.9 µg/g, lung 54.6 µg/g, kidney 15.1 µg/g, cerebrum 4.4 µg/g, gastric content 38.7 µg/mL and muscle 2.4 µg/g. Sulpiride concentrations were: heart blood 93.3 µg/mL, subclavian vein blood 97.3 µg/mL, bile 454.0 µg/mL, gall bladder 236.0 µg/g, heart 41.1 µg/g, liver 11.0 µg/g, lung 35.5 µg/g, kidney 16.2 µg/g, cerebrum 7.3 µg/g, gastric content 53.3 µg/ml and muscle 19.3 µg/g.

Discussion: In this case, doxepin and sulpiride concentrations in heart blood or subclavian vein blood were higher than literature reported lethal blood levels. However, these data demonstrate that doxepin and sulpiride have different distribution throughout the body. Doxepin and sulpiride are rapidly absorbed following oral ingestion and distribute into well-perfused tissues (lung, liver, heart and kidney) and then redistribute into skeletal muscle. Higher concentrations are present in bile, primarily due to hepatic metabolism.

Key Words: Doxepin, Sulpiride, Postmortem Distribution

A Complex Case of Murder Involving Zolpidem

Maria Teresa Pinorini-Godly^{1*}, Frank Sporkert², Antonio Osculati³, Marc Augsburger², Manuel Rusconi¹ and Ario Conti¹

¹Istituto Alpino di Chimica e di Tossicologia, Olivone, Switzerland, ²University Center of Legal Medicine, Lausanne-Geneva, Switzerland, ³Azienda Ospedaliera Universitaria di Varese, Unità Operativa di Medicina Legale, Varese, Italy

Objectives: We report a case of murder involving a severe intoxication with zolpidem. The toxicological analyses were critical for the resolution of this case which ended with a life sentence.

Materials and Methods: Samples of cardiac blood, bile, gastric content, liver and kidneys were analyzed in order to establish the presence of drugs, ethanol or other xenobiotics. Zolpidem was quantified after liquid-liquid extraction with butyl acetate at pH 9.0 by LC/MS/MS (Shimadzu LC-20 Prominence and AB Sciex 3200 Q Trap) using zolpidem-d₆ as internal standard. This method was validated earlier for the quantification of 25 benzodiazepines and the Z-drugs, zolpidem and zopiclone. The LLOQ for zolpidem was determined to be 5.0 µg/L.

Results: A 36 year old female body was found in the Lago di Como, Italy. She was missing for 7 days. The autopsy findings revealed, among other things, a large deep oblique wound on the anterior part of the neck with various wounds and fractures on the skull: both types of injuries were determined to be post-mortem. Furthermore, the presence of defense wounds on the upper part of the body (arms and chest) as well as the presence of a 13 week-old fetus were noted. The toxicology findings were as follows: presence of zolpidem in potentially toxic concentrations in the cardiac blood (1140 µg/L), bile (1500 µg/L), gastric content (5.3 mg/kg), liver (1.3 mg/kg) and kidneys (0.2 mg/kg).

The husband of the victim, a physiotherapist with a disconcerting double personality, was suspected and arrested by the police. He denied any involvement but finally revealed to the magistrate his intent to "attempt to kill the child". The dose of zolpidem administered to the victim was estimated to be at least 6 tablets (10 mg) based on the pharmacokinetic properties of zolpidem.

The investigation also revealed that the body remained in the water for about 5 days. The concentration of zolpidem in the gastric content suggested a recent intake of zolpidem shortly before the death. Literature data suggests that the distribution between peripheral blood and cardiac blood is about 1.5 to 2.0. The measured concentration was certainly influenced by the exposure of the corpse to water and by the post-mortem interval and the post-mortem diffusion phenomena. However, these factors are more likely in favor of an underestimation of the administered dose.

Conclusion: The final medical report stated that the case of death was probably due to an "acute mechanical asphyxia in a seriously altered subject, in respect with the alertness state, caused by a massive dose of hypnotic drugs". Finally, the author admitted that he gave a "calming herbal tisane" containing at least 8 tablets of Stilnox[®] prior to suffocating her with a sweater. He also tried to decapitate the victim after her death using a saw. The resolution of this case was possible thanks to the toxicological findings and the good collaboration of the Italian and Swiss investigators, the magistrate and the coroner. The accused was declared guilty of intentional homicide and sentenced to life in prison.

Key Words: Case Report, Murder, Zolpidem

6-Acetylmorphine of Unknown Origin in a Case of Morphine Overdose

Robert L. Herndon* and Norman A. Wade.

Maricopa County Office of the Medical Examiner, Phoenix, AZ, USA

Introduction: Heroin (3,6-diacetylmorphine) is synthesized by acetylating morphine. 6-acetylmorphine (6-AM) is its primary active metabolite, which is in turn metabolized to morphine. 6-AM is used as a definitive indicator that at least some of the morphine present in a human specimen results from acute heroin intoxication (as opposed to an administration of pharmaceutically-prepared morphine).

Case History: A case received by the Maricopa County Office of the Medical Examiner in Phoenix, AZ, in October 2010 contained investigative and toxicological findings that called into question the origin of 6-AM present in the postmortem cardiac blood sample. The case involved a 58-year-old male found unresponsive in his bed with medical history/findings that were sufficient to consider natural causes (hypertension and diabetes) as a preliminary manner of death. Two bottles of morphine from recently filled prescriptions were found on his nightstand. A total of 53 pills were noted missing.

Toxicology results of the cardiac blood for opiates included: unconjugated morphine: 3,179 ng/mL; 6-AM: 13 ng/mL; hydromorphone: 19 ng/mL; codeine (~1 ng/mL; below LOQ of 2.5 ng/mL). The opiate quantification was performed by solid phase extraction (SPE) and LC/MS/MS. More remarkable than the extremely high level of morphine was the notable presence of 6-AM in a case that had scene evidence suggesting an acute administration of prescription morphine and no indication of heroin abuse in the investigative findings. A variety of additional tests were conducted in attempt to verify and account for the unexpected 6-AM.

Testing was repeated in-house with similar results and a portion of the cardiac blood was sent to NMS Labs to act as a reference lab. In a panel testing for free and total opiates by GC/MS, they found: free morphine: 3,300 ng/mL; total morphine: 3,700 ng/mL; 6-AM: present, <10 ng/mL. Vitreous was the only other specimen drawn (no autopsy was performed). The in-house vitreous findings were: unconjugated morphine: 388 ng/mL; hydromorphone: 2 ng/mL. Tests were performed regarding some potential in vivo and in vitro morphine acetylation pathways that could account for the 6-AM found. Aspirin was present in the decedent's list of medications, so the cardiac blood was tested for salicylates through MEDTOX Laboratories, Inc., of which they found 20 mg/L. Phosphate buffer was substituted for the acetate buffer step in the solid phase extraction. (Other reagents used in the SPE and LC processes are: C8 + benzyl sulfonic acid SPE sorbent, methanol, water, nitrogen gas, methylene chloride, isopropanol, ammonium hydroxide, acetonitrile, formic acid, ammonium formate, and a PFP propyl LC column; maximum temperature: 40°C.) Comparable levels of unconjugated morphine and 6-AM were still found (averages of 3,229 ng/mL and 9 ng/mL, respectively). Each type of morphine pill found at the scene was tested in-house for 6-AM as a possible process impurity, but no detectable levels were found amongst concentrations of morphine similar to those found in the cardiac blood.

Conclusions: In conclusion, the origin of the 6-AM in the decedent's cardiac blood sample remains uncertain. We were able to rule it out as a pill contaminant or a product of the acetylation of morphine by the acetate buffer used in extraction. Sub-therapeutic levels of aspirin administered may have been sufficient to facilitate the amount of acetylation found, though the mechanism is unknown.

Key Words: Morphine, 6-Acetylmorphine, Acetylation

Relationship Between Femoral Blood and Liver Fentanyl Concentrations in Cause of Death DeterminationKalen N. Olson¹, Julie Kloss*², Owen Middleton³, and Fred S. Apple²¹HealthPartners, Bloomington, MN, USA; ²Hennepin County Medical Center and ³Hennepin County Medical Examiner's Office, Minneapolis, MN, USA

Objective: Our previous studies (Olson K et al. Am J Clin Path 2010;133: 447-53) showing postmortem redistribution of fentanyl in femoral blood suggest the need for an alternate specimen that more accurately reflects the true body burden of fentanyl in cases exposed to fentanyl at the time of death. The goal of the current study was to determine how liver tissue fentanyl concentrations correlate with blood fentanyl concentrations in medical examiner cases following both fentanyl overdose and therapeutic use of fentanyl.

Materials and Methods: Cases involving the presence of fentanyl, independent of the type of exposure, were compiled from four County Medical Examiner offices in Minnesota over a one year period, including Hennepin, Ramsey, Anoka and Dakota Counties. At autopsy femoral blood and liver tissue were collected. Extraction consisted of either 1 mL of whole blood or 1 mL of homogenate (5 g of tissue in 5 mL of water homogenized) mixed with 10 µL fentanyl-d5 internal standard (10 mg/L) and 3 mL of water and vortex mixed. It was then centrifuged at 1950 x g for 15 min, and the pellet was discarded. To the supernatant, 3 mL of 100 mM phosphate buffer was added and pH adjusted to 6. The specimen was transferred onto a solid-phase extraction column preconditioned with methanol, water and 100 mM phosphate buffer. Following treatments with water, 100 mM acetate buffer, and methanol, the column was eluted with methylene chloride, isopropanol, and ammonium hydroxide (78:20:2). The eluant was evaporated at 30–40°C with nitrogen, reconstituted with 0.05 mL ethyl acetate and transferred for analysis. Fentanyl concentrations were determined by gas chromatography mass spectrometry.

Results: A total of 30 cases with both femoral blood and liver tissue fentanyl concentrations were examined. Only 4 of 30 cases (13.3%) had fentanyl as the sole drug detected (fentanyl blood range = 7.7 to 52.5 µg/L; liver range = 45.0 to 138.6 µg/kg; liver:blood ratio = 0.9 to 18.0). For the 16 cases (53%) ruled as fentanyl toxicity as cause of death (fentanyl blood range = 4.5 to 52.5 µg/L; liver range = 45.0 to 191.2 µg/kg; liver:blood ratio = 0.9 to 18.0), 13 (43%) had liver fentanyl concentrations consistent with toxic concentrations (≥ 69 µg/kg), while 3 (10%) had liver concentrations that were indeterminate (32-68 µg/kg). For the 14 (47%) cases ruled as a mixed drug toxicity cause of death (fentanyl blood range = 2.2 to 36.8 µg/L; liver range = 8.2 to 218.2 µg/kg; liver:blood ratio = 1.5 to 66.8), 7 (23%) had liver fentanyl concentrations aligning with overdose levels (≥ 69 µg/kg), compared to 6 (20%) with indeterminate levels (32-68 µg/kg) and 1 (3%) with a therapeutic level (≤ 31 µg/kg). Overall there was a poor correlation of $r = 0.10$ between blood and liver fentanyl concentrations. In addition there were large and overlapping liver to blood concentration ratios in the different cause of death groups.

Conclusions: We recommend that fentanyl concentrations in both femoral blood and liver tissue be measured to assist the medical examiner in determining the role of fentanyl in cause of death. Liver concentrations are especially important to assist in differentiating cases in which blood concentrations may be increased due to postmortem redistribution. The growing evidence-based literature will assist in determining whether liver will replace blood as the specimen of choice.

Key Words: Fentanyl, Postmortem Redistribution, Liver

Fatal Consequences of Datura Poisoning in a Case of Robbery: Clinical, Toxicological and Forensic Features

Gilles Tournel^{1,2}, L. Humbert², J.F. Wiart², J. Pollard¹, Y. Delannoy¹, R. Cornez¹, D. Gosset¹, D. Allorge², M. Lhermitte² and V. Hédouin¹

¹Institut de Médecine Légale, CHRU de Lille, France ; ²Laboratoire de Toxicologie Médico-légale, Centre de Biologie et Pathologie, CHRU de Lille, France

Objectives: The objective of this study is to describe a case report involving the use of the Datura plant or an atropine and scopolamine poisoning in the death of a 35-year-old French man on the Island of Java.

Case History: A 35-year-old French man had been travelling for six months in South East Asia. During his journey, he decided to visit a volcano on the Island of Java with a tourist guide. Whilst travelling in the guide's car, he suffered violent digestive pain. The man became quickly unconscious and was taken by his guide to the nearest hospital, where he was admitted for a heart attack. Despite resuscitation attempts, he died two hours later. An autopsy was performed in Indonesia (no specimens were collected for toxicology) and, thereafter, the body was embalmed and treated with formalin products. Following repatriation to France, a second autopsy was requested by the judiciary. Some superficial wounds were observed on the body, but none were fatal. Furthermore, it was observed that all the organs, previously cut into multiple pieces and placed in the thoracic cavity, were fixed with formalin products. For toxicological analyses, some organs and hair were sampled and only vitreous humor could be taken for biological fluid analysis.

Toxicological findings: Alcohol analysis was performed by Gas Chromatography coupled with Mass Spectrometry. Ethanol was not detected, but methanol was identified in the vitreous humor at a concentration of 10 g/L. The detection of heroin, opiates, cocaine, amphetamines and drugs produced negative results, performed by Ultrahigh Performance Liquid Chromatography coupled with Tandem Mass Spectrometer (UPLC-MS/MS). The only positive findings were scopolamine and atropine/hyoscyamine. Vitreous humor concentrations for scopolamine and atropine/hyoscyamine were 5 ng/mL and 1 ng/mL, respectively. The results of hair analysis were negative for those two drugs. The identification of scopolamine, atropine/hyoscyamine was indicative of fatal Datura poisoning.

Discussion: The toxicity of the plant Datura is well known and has been related to deaths and poisonings for centuries. The main toxic compounds are tropane alkaloids: atropine, hyoscyamine (the levo-isomer of atropine) and scopolamine. Datura species are used as medicinal plants, as well as hallucinogens and as poisons for criminal activities. In the present case report, a tourist guide used Datura to stun and rob his customer, but the Datura mixture used was misprepared and, consequently, the victim overdosed. As there is no correlation between blood and vitreous humor scopolamine concentrations, it was impossible to confirm a fatal Datura poisoning. However, it was only after the guide confessed his criminal act (drink containing Datura given to customer), that the cause of death was determined. In addition, the body embalming was another problematic issue in the present case. Indeed, the presence of methanol in vitreous humor was difficult to interpret. Methanol, commonly found in adulterated alcohols, is frequently involved in fatal poisonings. However, the very high methanol concentration found in the vitreous humor of this case was indicative of contamination by the embalming products; that could not be, unfortunately, analyzed.

Key Words: Datura, Poisoning, Scopolamine

Determination of Barbiturates in *Postmortem* Whole Blood Sample Using Hollow Fiber Liquid-Phase Microextraction and GC/MS

Rafael Menck de Almeida ^{*1}, Saskia Carolina Seulin², Vilma Leyton², Victor Alexandre Percinio Gianvecchio³, Michael David Osselton⁴, Mauricio Yonamine¹.

¹Faculty of Pharmaceutical Sciences, University of São Paulo, São Paulo, SP, Brazil, ²Faculty of Medicine, University of São Paulo, São Paulo, SP, Brazil; ³Medicolegal Institute of São Paulo State, São Paulo, SP, Brazil; ⁴Centre for Forensic Sciences, Bournemouth University, UK

Supported by FAPESP and CNPq.

Introduction: It is estimated that three intoxication cases involving antiepileptic drugs (AED) occur daily in large urban areas with approximately 10 million inhabitants. Phenobarbital is the most common AED involved in intoxication cases. In fact, the incidence of death involving psychoactive substances is a growing problem in recent years. Blood is the sample of choice for detecting and interpreting drug levels in *postmortem* cases, however, blood obtained *postmortem* can vary considerably.

Objectives: The objective was to develop a gas chromatographic-mass spectrometric (GC-MS) method using hollow fiber liquid-phase microextraction (LPME) for the determination of barbiturates (phenobarbital, secobarbital, pentobarbital, and butalbital) in whole blood samples. LPME is a relatively new sample preparation technique that uses lower amounts of organic solvents and yields higher recovery rates than other miniaturized techniques.

Materials and Methods: 100µL of whole blood was transferred into a 5-mL glass tube, followed by the addition of 4.5 mL of hydrochloric acid 0.1 mol/L. A 30-cm polypropylene hollow fiber (Q3/2 Accurel KM,600 µm i.d., 200µm wall thickness and 0.2µm pore size), was filled with decanol in its pores, and used for each extraction. The fiber was filled with acceptor phase (100µL of an aqueous solution of pH 13), and introduced into the sample solution. During extraction, the system was vibrated using a vortex mixer. After extraction, the acceptor phase was withdrawn from the fiber and dried under a stream of nitrogen. The residue was re-suspended with ethyl acetate and trimethylanilinium hydroxide (TMAH - derivatizing agent). An aliquot of 1 µL was injected into the GC-MS and the derivatization reaction occurred in the injection port liner (flash methylation). Secobarbital-d5 was used as an internal standard for the analysis of secobarbital, and butalbital-d5 was used for all other barbiturates.

Results: The limits of detection were less than 100 ng/mL for all analytes. Recoveries were approximately 70% and calibration curves were linear over a concentration range of 100 to 8000 ng/mL. The method showed to be precise (RSD <15%) and sensitive, and can be applied in forensic cases with suspicion of involvement of barbiturates. Application of the method to a case in which a child received phenobarbital prior to death showed phenobarbital concentrations of 4,318 and 1,581 ng/mL were found in cardiac and femoral blood, respectively.

Conclusion: This is the first report in which LPME was used as sample preparation technique in methods to detect substances in biological specimens for forensic purposes.

Key Words: Postmortem Whole Blood, Forensic Toxicology, Barbiturates

The Relationship Between Ante- and Post-Mortem Amlodipine Concentrations in Whole Blood Versus Plasma

Jennifer Button*¹, Peter Minty¹, Fiona Perry¹, Priya Suman¹, Denise McKeown², Malgorzata Puchnarewicz² and David W Holt². ¹Forensic Science Service Ltd, Lambeth, London, UK; ²Analytical Unit, St Georges - University of London, London, UK

Objective: Amlodipine is a third generation dihydropyridine calcium channel blocker, indicated for the treatment of hypertension and angina. To date there are very few cases of amlodipine overdose reported in the scientific literature. We present our data on amlodipine concentrations detected in plasma samples from compliant patients, post-mortem blood samples of individuals who have died of unrelated causes and those from individuals who have reportedly taken an intentional overdose of the drug.

Methods: Amlodipine was extracted from 100 μ L sample using liquid-liquid extraction into methyl-tert-butyl-ether, after the addition of bromperidol as the internal standard and 2M tris for pH control. They were then back extracted from the organic phase into 1% formic acid (250 μ L). An aliquot (25 μ L) of the extract was injected onto an Alltech, Alltima C18 (150mm x 2.1mm, 5 μ m) column. The mobile phase consisted of 80% methanol supplemented with 5mM ammonium formate. A Sciex API2000 triple quadrupole mass spectrometer equipped with a turbo-ion spray interface was used to detect the precursor and product ion transitions m/z : 409/238 (amlodipine) and m/z : 420/165 (bromperidol) in positive ionisation mode. The method was linear from 2.5 to 100ng/mL. The within and between-assay precision was <12.1% and <13.9% respectively. Accuracy ranged between 94% and 97%. The absolute recovery averaged 69% across the calibration range. No significant matrix effects were observed following pre and post extraction standard addition to 6 different sources of matrix (maximum bias of +6.8%).

Results: In a control population of patients on a once daily 5mg (n=9) or 10mg (n=8) dose, the mean random plasma amlodipine concentrations were 7ng/mL (3-13ng/mL) and 14ng/mL (5-25ng/mL) respectively. These are in good agreement with those reported in the published literature. The average post-mortem peripheral blood concentration of amlodipine in deaths (n=25) not attributed to the drug was 40ng/mL (2-131ng/mL). The average drug concentration in amlodipine related deaths (n=4) was 325ng/mL (250-430ng/mL) in femoral post-mortem blood. Concentrations of 393ng/mL and 179ng/mL were detected in paired ante-mortem whole blood and plasma samples, respectively, in one individual who died following a combined paracetamol (108mg/L) and amlodipine overdose. In cases where paired blood and vitreous humour samples were submitted (n=3) the amlodipine concentrations in the post-mortem peripheral blood were 10-19x greater than those detected in vitreous humour.

Conclusion: In most instances, amlodipine was detected in the presence of multi-drug intoxication, making it difficult to ascertain the extent of its contribution to death. The toxic effects (excessive peripheral vasodilatation and marked systemic hypotension) may coincide with peak drug absorption and manifest long after (>7hr) an overdose. It is important that clinicians are aware of this as a potential management problem. Comparison of ante- and post-mortem concentrations following therapeutic use of the drug suggests it undergoes significant re-distribution; this is anticipated from amlodipine's high volume of distribution. It is unknown how serum/plasma ratios compare to whole blood drug concentrations. The paired ante-mortem whole blood and plasma samples indicate that this could be an important consideration for interpretation; however a larger data set is required to test this. Additionally, amlodipine is photo labile, and while samples were analyzed as soon as was practically possible, photodecomposition in the intervening period cannot be excluded.

Keywords: Amlodipine, Post-mortem, Overdose

Fatal Methanol Intoxication - Two Exceptional Case Reports

Annika M. Dally*, Cornelia Brehmer, Milena M. Madry, Sabine Franckenberg, Rosita Martinez, Bruno Vonlanthen and Thomas Kraemer

Institute of Legal Medicine, University of Zurich, Zurich, Switzerland

Objective: Two independent cases of methanol ingestion are presented. In case I, a middle-aged male was found dead in a public toilet. In case II, a 53-year-old female laboratory assistant was hospitalized with symptoms such as dizziness, nausea, impaired vision and a systolic blood pressure over 250 mm Hg. The woman fell into a coma despite a correct diagnosis and immediate therapy (hemodialysis, ethanol 1g/L). One month after hospitalization, the woman died due to irreversible central nervous system lesions.

Materials and Methods: Methanol levels were determined in postmortem samples (blood, urine, gastric content) from the male decedent. All available clinical and postmortem samples from the hospitalized woman were analyzed for methanol. In addition, the methanol metabolite formic acid, ethanol from antidote therapy and a marker for ketosis (β -hydroxybutyric acid) were determined using gas chromatography electron capture detection (GC-ECD) or headspace gas chromatography mass spectrometry (HS-GC-MS). Ethyl glucuronide (EtG) was determined in hair in both cases using GC-negative chemical ionization (NCI)-MS. Systematic toxicological analysis was performed using GC-MS after enzymatic hydrolysis, liquid-liquid extraction and acetylation.

Results: Methanol concentrations were 3.3 g/L of blood for case I and 1.5 g/L of plasma for the first clinical sample of case II. Fatal methanol concentrations in blood have been reported over a range from 0.2 to 6.3 g/L. Ethanol was not detected in these blood samples. Methanol could no longer be detected 18 h after admission. Ethanol concentration in blood was 1.1 g/L (from ethanol therapy). To check for ethanol abuse, hair was analyzed for ethyl glucuronide (EtG). In both cases, EtG concentrations were under 7 pg/mg, indicating ethanol abstinence. The indicator of ketosis, β -hydroxybutyric acid, was in the physiological range (normal serum concentrations occur up to 340 μ mol/L [= 3.54 mg/dL]). Central failure of regulatory functions was claimed as the cause of death in both cases. Hemorrhagic necrosis was observed in case II because of the longer survival time.

Conclusion: Two cases of independent fatal methanol intoxications without additional ingestion of ethanol are presented. Hemorrhagic necrosis was observed in the case with the longer survival time.

Key Words: Methanol Intoxication, Ethanol, Hemorrhagic Necrosis

Development of Drug Identification and Semi Quantitative Analytical Program by Gas Chromatography-Mass Spectrometry Based on Drug Patterns in Autopsy Cases of Korea

Eunmi Kim*, Eunyoung Han, Sanggil Choe, Hyojeong Hong, Sujin Jeong, Jongsook Rhee, Hyesun Yeom, Sangki Lee and Heesun Chung

National Forensic Service, Seoul, Republic of Korea

Objectives: Systematic toxicological analysis (STA) is a process for general unknown screening of drugs and toxic compounds in biological fluids. To establish STA, first we investigated patterns of drugs & poisons in autopsied cases during 2007-2009 in Korea, and selected 62 target drugs with high frequency rates of detection in postmortem specimens. Next, we developed a rapid and simple drug identification and quantitative analytical program by gas chromatography-mass spectrometry (GC-MS). The in-house program, "DrugMan", consisted of modified Chemstation data analysis menu and newly developed macro modules.

Materials and Methods: Spiked standards were extracted by solid-phase extraction (SPE) with trimipramine-d₃ as an internal standard. Calibration curves for the drugs studied were divided into four concentration ranges based upon consideration of their therapeutic or toxic concentrations in blood specimens, i.e. 0.05-1 mg/L, 0.1-1 mg/L, 0.1-5 mg/L or 0.5-10 mg/L. Parameters such as retention times, 3 mass fragment ions, and calibration curves for each drug were registered into the DrugMan software. Linearity, LODs and LOQs, sensitivity rates, intra- and inter-day run precisions and accuracies were performed for the validation of DrugMan.

Results and Discussion: During 2007-2009 the three drugs with the highest incidence rate, were atropine, chlorpheniramine and lidocaine. Meanwhile cyanide showed the highest frequency for poisons, with an incidence of 32 cases in 2009. In the case of pesticides, poisoning by paraquat (herbicide, 17 cases) showed the highest frequency. Fifty-five drugs out of 62 target drugs were entered and applied into the DrugMan software; the entries included 14 antidepressants, 8 antihistamines, 5 sedatives/hypnotics, 5 narcotic analgesics, and 3 antipsychotic drugs. Calibration curves for most drugs were linear with correlation coefficients exceeding 0.98. LODs and LOQs for the 55 drugs were represented in two ranges from 0.01-0.05 mg/L and 0.05-0.1 mg/L, respectively. Sensitivity rate by DrugMan was 0.90 (90 %) at the levels of 0.5 mg/L. The intra- and inter-day run imprecision (CV) for 29 spiked test specimens were less than 18.5 %, and the inaccuracies (bias) were less than 28% at the level of 0.5 mg/L. This approach can be used to automate the identification, semi-quantitation and reporting of target drugs within one minute. This makes the DrugMan approach very effective for targeted qualitative drug screening with semi-quantitative results. By further expanding the list of drugs registered into the DrugMan software, through the selection and application of additional analytes from current and additional pharmaceutical categories, this approach could be a selective and useful tool for STA in forensic toxicology.

Key Words: Systematic Toxicological Analysis (STA), GC-MS, DrugMan, Drug Screening

Rapid Analysis of Liver, Muscle and Vitreous Humor Samples Using the Randox Whole Blood Drugs of Abuse (DOA) Arrays for Use as a Near-Body Screen During Autopsy

Poppy A. McLaughlin*¹, Derrick J. Pounder², Susan Cox¹ and M. David Osselton¹.

¹Centre for Forensic Sciences, Bournemouth University, Poole, UK; ²Centre for Forensic and Legal Medicine, Dundee, UK

Introduction: We have previously reported use of the Randox whole blood DOA arrays with alternative post-mortem samples. This paper is a continuation from this work with the inclusion of a wider range of drugs, larger number of samples analysed as well as a further developed tissue preparation method which reduces preparation time to just a few minutes. As with previous work, aliquots of blood, urine, vitreous humor, muscle and liver were screened using one, or a combination of, DOA I, DOA I+, DOA II, Forensic and Custom DOA panels. The capability to screen a range of post-mortem samples is of value in cases where conventional samples are unavailable e.g. exhumations or decomposed and embalmed bodies.

Method: Femoral blood, urine, vitreous humor, liver and psoas muscle were obtained. 2 x 1 cm³ tissue samples were collected. One tissue sample was homogenised with assay SPE diluent (1 mL), centrifuged (10 mins, 3000 rpm) and 60 µL of supernatant transferred to a conical bottomed Eppendorf tube. The second tissue sample was compressed and 60 µL of extracted fluid was collected. Blood, urine and vitreous humor (60 µL) were transferred directly to Eppendorf tubes as per the tissue supernatant. All samples were diluted 1:3 with assay SPE diluent and applied to the immunoassay following the manufactures protocol for whole blood. Blood samples from each case subsequently underwent confirmatory analysis using liquid chromatography with diode array detection and tandem mass spectrometry.

Results: There was 100% agreement between confirmatory analysis and immunoassay results for buprenorphine, fentanyl, ketamine, LSD, methaqualone, propoxyphene, salicylate, salicylic acid, zaleplon, zopiclone and zolpidem. The remaining drugs were >90% in agreement with confirmatory analysis. The discrepancies between assay screening and confirmatory analysis may reflect differences in drug distribution between tissues. For PCP and cannabinoids, no confirmatory analysis was carried out but a good agreement was found between assay detection and case history. Results obtained from homogenised liver and pressed liver samples were within 99% agreement with one another. Insufficient fluid was obtained from pressed muscle for direct analysis however muscle homogenates provided results that were in excellent agreement with their respective blood specimens that underwent confirmatory analysis.

Conclusions: The Randox whole blood arrays can be used in cases where alternative specimens are submitted for toxicological testing. The developed liver preparation method reduces preparation time by ~15 minutes allowing even more rapid results to be obtained. The procedure is simple and the entire process can be undertaken in the mortuary offering an opportunity to perform rapid near-body drug screening during the post-mortem examination.

Keywords: Screening, Post-Mortem, Alternative Samples

Toxicological Screening of Human Hair after Exhumation: The Potential Interest of Insect Pupae**Luc Humbert***, Jean François Wiart, Camille Richeval, Gilles Tournel and Michel Lhermitte

Laboratoire de Toxicologie, Centre de Biologie - CHRU de Lille, 59037 Lille, France

Case: A 35-year-old woman was buried without forensic investigation after being found dead in her bed, despite her family expressing concern about her and partner and demanding an autopsy. Three years after the fact, a judge authorized an autopsy and toxicological testing. Only bone and hair remained of the highly decomposed body. Hair was sampled and sent to the laboratory. The sampling bag contained a lock of hair but also a large number of insect pupae that were also analyzed.

Materials and Method: After washing, two 1 cm segments of hair (root side) were taken from the lock of hair and cut into 1 mm fragments; several pupae were also pulverized. The hydrolysis of hair and pupae was carried out in a 0.1N HCl solution overnight at 56 °C. The hydrolysates were neutralized with 1 mL of 0.1 N NaOH then extracted by dichloromethane/diethyl ether (90/10 v/v) in phosphate buffer (pH = 8.4). The organic phases were then evaporated to dryness and the dry extracts reconstituted with 100 µL of the mobile phase. The LC separation was performed using a UPLC system (Waters) with an ACQUITY HSS T3 column (150 mm x 2 mm, 1.8 µm particle size) under gradient conditions. The analysis time was 15 minutes. The MS detector was a TQD (Tandem Quadrupole Detector) from Waters, equipped with an ESI probe. The MRM method used 2 characteristic transitions for each molecule, with optimized parameters (cone voltage, collision energy, dwell time). More than 388 MRM were acquired for 187 molecules.

Results and discussion: Methadone and its metabolite EDDP were detected in all samples:

ng/mg	Segment 1	Segment 2	Pupae
Methadone	0.54	0.05	0.30
EDDP	0.72	0.06	0.17

Hair analysis revealed consumption of methadone in concentrations indicative of casual usage; the presence of methadone and EDDP in insect pupae that developed on the flesh of the deceased [1] indicated that she had taken methadone in the preceding days or hours before her death.

Conclusion: The exhumation three years post mortem found a body totally decomposed with only bone and hair available for analysis. Hair analysis revealed occasional consumption of methadone unknown to the deceased's relatives. The analysis of accompanying insect pupae demonstrated that she had consumed methadone in the preceding days or hours before her death, raising the possibility that the drug could have been a causal element in her death. This case illustrates the interest and the information from a broad screening on pupae when the biological matrices more usually analysed post mortem have disappeared.

References:

[1] Gosselin M, Ramirez Fernandez Mdel M, Wille SM, Samyn N, De Boeck G, Bourel B. Quantification of methadone and its metabolite 2-ethylidene-1,5-dimethyl-3,3-diphenylpyrrolidine in third instar larvae of *Lucilia sericata* (Diptera: Calliphoridae) using liquid chromatography-tandem mass spectrometry. *J Anal Toxicol.* 2010;34(7):374-80.

Key Words: Pupae, Methadone, LCMSMS

Barbitone (Barbital) and Death in the Workplace

Malgorzata Puchnarewicz^{1*}, Gwen Wark², Gemma Coombes¹, Terry D Lee¹, David W Holt¹ and Atholl Johnston¹
¹Analytical Unit, St. George's, University of London, UK; ²SAS Peptide Section, Royal Surrey County Hospital, UK

Objective: A 41 year old laboratory worker was found by a cleaner, reclining in an office chair in the early morning. There were empty insulin pens by the computer. Post-mortem urine and femoral blood samples were sent to the Analytical Unit for a routine toxicological analysis. An aliquot of blood was also subjected to insulin analysis. Full systematic blood and urine screens were performed and a broad range of prescribed medications was targeted. The urine sample was analysed using the cloned enzyme donor immunoassay (CEDIA) for drugs of abuse and resulted in a positive for barbiturates. The extracted blood sample was run on a full scan gas chromatography/mass spectrometry (GC/MS) to identify the barbiturate and barbitone quantification was performed using selected ion monitoring (SIM).

Materials and Method: Barbitone (barbital) and tolybarbituric acid were obtained from Sigma-Aldrich. Barbitone was extracted from blood via liquid-liquid extraction with 2M potassium dihydrogen orthophosphate buffer and MTBE. The GC/MS system consisted of a Shimadzu GC/MS-QP 2010 and Shimadzu AOC-20i autosampler. Helium was used as the carrier gas and an HP-5MS column (30m x 0.25mm, 0.5µm film thickness) for separation. The injector port was held at 225°C. The initial column temperature was set at 80°C and held for 4 minutes. It was ramped by 20°C per minute up to 280°C and held for a further 2.5 minutes. 1µL of sample was injected in splitless mode. Electron impact ionization (EI) was utilised in full scan mode to identify barbitone (m/z: 156, 141, 112, 98). Quantification was performed monitoring m/z: 141 and 218 for barbitone and tolybarbituric acid (internal standard), respectively.

Results: Barbitone was detected in blood at a concentration of 312mg/L. The concentration associated with fatality is greater than 90mg/L. Insulin concentration was 64pmol/L and C-peptide was less than 94pmol/L. These results were consistent with exogenous insulin administration but the level of insulin was underestimated due to haemolysis of the blood sample and the time delay between sample collection and analysis.

Conclusion: Urine specimens are not always available or submitted in post-mortem cases and blood barbiturates analysis is not routinely performed in many laboratories. Barbitone is no longer prescribed; it was withdrawn in the 1950s due to drug tolerance. Today it is commonly used as a chemical for the preparation of buffers for immunoelectrophoresis of protein on gels or separation of serum proteins and enzymes. Barbitone is present in many laboratories in solid form or buffer solution and may represent a latent hazard.

Key Words: Barbitone, Laboratory, Death

Poisoning Deaths in the Region of Epirus, North-Western Greece During the Period 1998-2010**Vassiliki A. Boumba*** and Theodore Vougiouklakis

Departments of Forensic Medicine & Toxicology Medical School, University of Ioannina, 45110 Ioannina, Greece

Objective: The aim of this study is to describe the epidemiologic characteristics of the fatal poisonings in Epirus, north-western Greece during the period 1998-2010.**Materials and Methods:** The study material consisted of all deaths officially certified in the autopsy report as resulting from poisoning during the study period in the region of Epirus. For each case full medicolegal and toxicological investigation was performed. Toxicological analyses were performed normally on blood and urine. The parameters collected for evaluation were class of toxic substance(s), age, gender, and cause of death.**Results:** During the study period 126 cases out of a total 3206 autopsies (3.9%) were classified as poisoning deaths. The victims were 99 males (78.6%) and 27 females (21.4%). The age of the male victims ranged from 16 to 97 years (mean 42 ± 18 ; median 38) while the age of the female victims ranged from 16 to 95 years (mean 53.9 ± 27.6 ; median 63). In accordance with the cause of death, 99 cases (78.6%) were accidents, 20 cases (16%) were suicides and 7 cases (5.6%) were of undetermined intent. Accidental and suicidal poisoning deaths rates were 1.19 and 0.62 per 100,000 inhabitants per year the period 1998-2002 respectively versus 3.41 and 0.35 per 100,000 inhabitants per year the period 2007-2010 respectively. Seventy six cases (60%) were the result of drugs of abuse consumption, 25 cases (19.8%) the result of carbon monoxide poisoning, 12 cases (9.5%) the result of pesticides uptake, 6 cases (4.8%) the result of corrosive ingestion, 6 cases (4.8%) the result of pharmaceuticals overdose, while 1 poisoning death (0.8%) was the result of spider bite. The incidence of different drugs of abuse among the drug abusing victims was: heroin in 65 cases, ethanol in 38 cases, benzodiazepines in 36 cases, cocaine in 17 cases, cannabinoids in 17 cases, amphetamines and anabolics in 1 case. Drugs of abuse poisoning was the main cause of death for the age group up to 50 years old (68 of 76 cases, 89.5%) while for the age group older than 50 years old carbon monoxide inhalation, pesticides and corrosives ingestion were the primary causes of death (18 of 25 cases, 72%; 8 of 12 cases, 67%; and 5 of 6 cases, 83% respectively). The fatality rates due to drugs of abuse were 0.79 and 2.55 per 100,000 inhabitants per year the time periods 1998-2002 and 2007-2010 respectively. Ethanol was detected in 55 cases out of the total 126 cases ranging from 0.1 to 5.8 g/L (mean 1.34 ± 1.45 g/L; median 0.65 g/L).**Conclusions:** (i) Rising rates in accidental poisoning deaths were recorded. (ii) This rise was mainly due to the increase of drugs of abuse related deaths. (iii) Decline in suicidal poisoning deaths was recorded. (iv) Heroin was responsible for most drug of abuse fatalities. (v) Ethanol was the most common substance involved in all poisoning deaths.**Key Words:** Poisoning Death, Accident; Suicide

Diving Under the Influence of Drugs

Marion Villain* and Pascal Kintz

X-Pertise Consulting, 84 route de Saverne, 67205 Oberhausbergen, France.

Objective: To discuss the relationships between drugs and diving, documented by a fatal case

Case History: We present here the case of a 52 year-old man (1.72 meters, 85 kg), PADI advanced open water diver. He was on holiday in a tropical island to have fun and practice scuba diving. He was a regular diver with a total of about 300 dives. The day of the accident, he was diving in the 24m area, using an air tank. After a feeling of sickness under water, the man died of a cardiac arrest while surfacing. He was suffering from heart rhythm problems and was taking amiodarone. The autopsy revealed marked arteriosclerosis (70%) and slight signs of drowning. The toxicological analyses in blood demonstrated the presence of alprazolam (8ng/mL), diphenhydramine (61ng/mL) and amiodarone (4.3mg/L), in accordance with therapeutic treatment. We were requested to document the case for two issues: influence of the drugs on the cardiac arrest and influence of the drugs on nitrogen narcosis.

Discussion: All the measured concentrations are therapeutic. According to medical guidelines for divers, it is recommended to consider the condition/illness/disease for which the medication is being given and to check if the condition could be dangerous underwater; to verify that there are not any effects of the drug that alter consciousness or cause alteration in decision making ability; to check for any side effects of the drug that could be dangerous underwater; and to consider complex relationships between drugs, the individual, other medications, diet and the conditions for which the drugs are taken. At the present time, the most likely reason for a diver over the age of 40 to die suddenly while diving is a heart attack with an accompanying fatal heart rhythm. A factor is exertion, which causes the heart to work beyond its capacity to obtain oxygen. The lack of oxygen causes the heart to malfunction, and a fatal heart attack may occur. Nitrogen narcosis, also called "rapture of the deep" and "the martini effect," results from a direct toxic effect of high nitrogen pressure on nerve conduction. It is an alcohol-like effect, a feeling often compared to drinking a Martini on an empty stomach: slight giddiness, wooziness, and becoming a little off balance. Nitrogen narcosis is a highly variable sensation but always depth-related. Some divers experience no narcotic effect at depths up to 40m, whereas others feel some effect at 24m. Underwater, of course, this sensation can be deadly. When reviewing this case, it appears that there is a lack of data dealing with pharmaceuticals and effects on diving. Diphenhydramine is a popular remedy for motion sickness often used by divers on the boat. Given the concentration of amiodarone, it is unlikely that it has an influence on the cardiac arrest; quite the reverse, it may possibly have a protective effect against development of a fatal arrhythmia. A combined effect of alprazolam and diphenhydramine on the possible nitrogen narcosis cannot be totally excluded.

Conclusion: Most people with coronary artery disease should not dive without correction of their problem. The blocked arteries increase the risk of sudden death or unconsciousness due to arrhythmias due to the extra demand of the exercise involved. We excluded the contribution to death of amiodarone but the one of the depressants is still under debate.

Key words: Diving, Drugs, Arteriosclerosis, Nitrogen Narcosis

Determination of Δ^9 -Tetrahydrocannabinol and 11-nor- Δ^9 -Tetrahydrocannabinol-9-carboxylic Acid Bile Concentrations and their Importance in the Investigation of Forensic Cases

Ioannis Papoutsis, Panagiota Nikolaou, Artemis Dona, Constantinos Pistos, Maria Stefanidou, Chara Spiliopoulou and **Sotirios Athanasis***

Department of Forensic Medicine and Toxicology, School of Medicine, National and Kapodistrian University of Athens, Athens, Greece

Objectives: The determination of Δ^9 -tetrahydrocannabinol (THC) in blood is important in human performance and postmortem toxicology in order to correlate blood concentrations with impaired performance or behavior. Investigating toxicological causes of death may require alternative matrices such as bile, especially when blood samples are not available. The aim of this study was the development and validation of a gas chromatography/mass spectrometric method for the determination of THC and 11-nor- Δ^9 -Tetrahydrocannabinol-9-carboxylic acid (THCCOOH) in bile in order to correlate bile concentrations with the respective postmortem blood concentrations.

Materials and methods: The method includes protein precipitation by acetonitrile and solid-phase extraction using Bond Elut LRC Certify II columns followed by silylation using BSTFA with 1% TMCS in acetonitrile. THC-d3 and THCCOOH-d3 (25.0 ng/mL) were used as internal standards. Mass spectrometric detection of the analytes was performed in the selected ion monitoring mode after electron impact ionization. The mass fragments used for the qualitative analysis of the analytes were **371**, 386 and 303 for THC (**374** for THC-d3), and **371**, 473 and 488 for THCCOOH (**374** for THCCOOH-d3), whereas the bold marked ions were used for the quantification of analytes.

Results: The absolute recovery of the developed method was higher than 87.5% for both analytes. LOD and LOQ were 0.7 and 2.0 ng/mL, respectively. The calibration curves were linear within the dynamic range (2.0-200 ng/mL) with a correlation coefficient higher than 0.993. The validated method was applied to 30 bile samples from forensic cases after positive cannabinoid immunoassay screening tests in urine. When THCCOOH and/or THC were present in blood samples their presence was always confirmed in bile samples. In some cases, THC and THCCOOH were not detected in blood although THCCOOH was detected in bile. The bile to blood THC concentration ratios varied from 0.1 to 7.0, whereas the bile to blood THCCOOH concentration ratios varied from 24.1 to 98.4.

Conclusion: Bile can be used as an alternative sample especially in cases where blood samples are not available or are negative for cannabinoids. Bile concentrations of THC and THCCOOH are generally several folds higher than the respective blood concentrations. The bile to blood concentration ratio at the moment of death is influenced by individual variations of pharmacokinetics and toxicokinetics of THC and THCCOOH and the interval between cannabis intake and death. Postmortem redistribution mechanisms can also affect THC and THCCOOH concentrations in bile.

Key Words: Cannabinoids, Bile, GC/MS

Postmortem Hair Analysis Verifies Heroin Exposure and Leads to a Killer

Ioannis Papoutsis, **Sotiris Athanaselis***, Panagiota Nikolaou, Chara Spiliopoulou, Maria Stefanidou. Department of Forensic Medicine and Toxicology, School of Medicine, University of Athens, Athens 115 27, Greece

Objectives: This case-report concerns the determination of opiates in hair from a 28-year old female, who was missing and found dead after 18 months. After identification through DNA analysis, toxicological analysis of hair samples was carried out.

Methods: A GC/EI-MS method was used for the determination of opiates in hair. After decontamination of hair (300 mg) by washing with shampoo, dichloromethane, isopropanol and acetone, opiates were extracted using HCl 0.1 M (50°C for 24h) followed by solid-phase extraction with mixed-mode columns (Bond Elut LRC Certify, Varian). After the extraction procedure, analytes were derivatized by *N, O*-Bis(trimethylsilyl)trifluoroacetamide with 1% trimethylchloro-silane at 70°C for 30 min. Analysis was carried out by gas chromatography electron impact mass spectrometry (GC/EI-MS, Agilent 6890N/5975) with an HP-5-MS fused silica column at selected ion monitoring (SIM) mode. The mass fragments used for identification in this method were: *m/z* **429**, 401, 414 and 146 for silylated morphine, *m/z* **371**, 356, 343 and 234 for silylated codeine and *m/z* **399**, 340, 384 and 324 for silylated 6-acetyl-morphine, whereas the mass fragments used for the silylated morphine-d₆, codeine-d₆ and 6-acetyl-morphine-d₆ (internal standards) were **435**, **377** and **405**, respectively (the bold marked ions were used for the quantification). LOD and LOQ of the analytical method were 0.005 and 0.015 ng/mg hair, respectively, for all three analytes (morphine, codeine and 6-mono-acetyl-morphine). The calibration curves for all three analytes were linear within the dynamic range of 0.015-1.5 ng/mg hair ($R^2 \geq 0.992$), and intra-/inter-day imprecision of the method were less than 7.7 and 8.9%, respectively.

Results: The concentrations of opiates found in hair are presented in the following table:

Opiate	Concentration (ng/mg hair)
Morphine	0.083
Codeine	0.050
6-mono-acetyl-morphine	0.033

Conclusions: This case concerns a 28-year old woman, who disappeared from a small town of the Greek countryside where she had gone for summer holidays with her new boyfriend. Eighteen months after her disappearance, skeletal remains with cranium and some hair were found in a field not far from the town where the woman disappeared.

The deceased was identified from her jewels and clothes that she was wearing, as well as from DNA analysis. The identification of opiates in the hair of the victim led the police authorities to the brother of her boyfriend who was a known heroin-addict. After thorough interrogation, he confessed that he had an affair with his brother's girlfriend. They misused heroin together for several months. After an argument he strangled her and threw her into a nearby river. The dead body was carried away by the waters of the river to the site where the skeletal remains were found.

Key Words: Opiates, Hair, GC/MS

Interpretation of High Blood Clozapine Concentrations - A Case Report

Ioanna Vardakou, Artemis Dona, **Sotiris Athanasis***, Constantinos Pistos, Maria Stefanidou and Chara Spiliopoulou
Department of Forensic Medicine and Toxicology, School of Medicine, University of Athens, Athens 115 27, Greece

Objectives: A fatal case related to clozapine is presented. A 50 year-old psychotic patient under clozapine treatment was found dead in his apartment. An empty box of Leponex (100 mg) was found close to the body suggesting clozapine intake. Postmortem findings showed pulmonary oedema and lung congestion. The cause and the manner of death remained undetermined after autopsy. Femoral blood samples were the only biological materials sent to the toxicology laboratory.

Materials and methods: Clozapine and norclozapine levels were determined in decedent's blood samples. A sensitive and specific GC/MS method that was developed, optimized and validated in our Laboratory, for the determination of clozapine and norclozapine, was used after adaptation to whole blood. Specimen preparation includes solid-phase extraction of both analytes and further derivatization with trifluoroacetic anhydride. Limits of detection (LOD) were 0.45 ng/mL for clozapine and 1.59 ng/mL for norclozapine, while limits of quantitation (LOQ) were 1.37 ng/mL for clozapine and 4.8 ng/mL for norclozapine. LOD and LOQ values were calculated at $3.3 \sigma/S$ and $10 \sigma/S$, respectively, where S is the slope of each calibration curve and σ is the standard deviation of y-intercept of each regression equation (n=6).

Results: Concentrations of clozapine and norclozapine in decedent's blood were found to be 1851 and 979.6 ng/ml, respectively. These levels were significantly higher than therapeutic range (300–600 ng/ml). No other drugs or alcohol were determined during toxicological analysis.

Conclusions: A case that points out the need for careful evaluation of the result of postmortem analysis in clozapine related deaths is presented. In this case the death was finally attributed to clozapine intoxication (due to the lack of history, other autopsy or histological findings and to the fact that autopsy was performed 6 hours after death) but the manner of death remained undetermined. In animals, serum clozapine levels can increase up to 300% during the 4–12 h postmortem interval; norclozapine also undergoes significant post-mortem redistribution. A quantitatively similar redistribution is known to take place in man. The interpretation of the results of the toxicological analysis in clozapine related cases should be performed carefully taking into consideration the possibility for, sometimes extensive, postmortem redistribution of the drug.

Key words: Clozapine, Noreclozapine, Postmortem Concentrations

Methadone-Related Deaths: A Worrying Increase

C. Vignali*, C. Stramesi, F. Pozzi and A. Groppi
Department of Legal Medicine, University of Pavia, Italy

Objectives. Methadone has been used in Italy in maintenance programs for heroin addicts since the early 1980s. Its use requires a careful evaluation of the dosage, in relation with the opioid tolerance developed by the patient under treatment. The number of methadone-related deaths observed by our laboratory has been increasing during the last five years. The aim of this work is to discuss the possible causes of such an increase, whether there has been an increase in methadone use without medical prescription, an incorrect use of the drug when take-home doses were prescribed, simultaneous consumption of alcohol or drugs, or even doctors at the Addiction Units misjudging the appropriate methadone dosage.

Materials and Methods. Between 2006 and 2010 we observed twenty cases of lethal poisoning related to methadone administration, seven of those in the year 2010 alone. Fifteen were males and five females, the average age being 32 (min 2 - max 54). The following toxicological analyses were carried out on postmortem samples: HS-GC quantitative analysis of ethanol in blood; GC-MS systematic toxicological analysis (STA) in blood followed by quantitative determination of identified drugs; GC-NPD determination of methadone in blood and in urine when available. Whenever possible (12 cases) GC-MS quantitative determination of methadone and morphine in hair (2 cm closest to the scalp) was performed.

Results. It has been established that half of the deaths had been caused by methadone only, while in the other ten there had been contribution, besides methadone, of other substances (especially ethanol). The evaluation of the anamnestic data has allowed us to observe that six of the deceased subjects were not following any methadone therapy, five had take-home methadone doses, while three other subjects had started methadone therapy just a few days earlier. In three of the remaining six cases, all involving subjects with supervised methadone consumption, blood alcohol concentration was over 200 mg/100 mL, and in one case there were high concentrations of Promethazine and Levomepromazine, the only medications found besides methadone. Highest blood methadone average concentrations (891 ng/mL) were surprisingly those related to subjects who had just started methadone treatment, followed by those of subjects with take-home doses (720 ng/mL). Lowest concentrations (455 ng/mL) were, conversely, those of subjects who had taken methadone without a doctor's prescription and those of patients with supervised consumption by a drug treatment service (695 ng/mL).

Conclusion. By evaluating the results we came to the following conclusions: 1) the death of three patients during induction into methadone treatment have been caused by administration of excessive starting doses; 2) when take-home doses are prescribed, sometimes patients display a tendency to irregular consumption of the drug, this being documented through the occasional findings of unconsumed syrup bottles at the patient's domicile and through hair analysis, subsequently increasing the risk of overdosing; 3) in one single case, take-home methadone has indirectly lead to the death of a two years old girl who drank the syrup left unattended by her father; 4) among subjects with supervised consumption, high blood concentrations have generally not been observed, but there has been simultaneous intake of alcohol or psychotropic drugs; 5) the abuse of methadone illegally obtained, often through patients allowed to carry it home, is rather common. Special caution has to be exercised in prescribing take-home doses, together with a more careful evaluation during induction into methadone treatment when tolerance is unclear.

Key Words: Methadone, Intoxication, Blood Levels

Fatal Intoxication Due to Dichloromethane Exposure: a Case Report

C. Stramesi*, C. Vignali, F. Pozzi and A. Groppi

Department of Legal Medicine, Forensic and Pharmaco-Toxicological Science, University of Pavia, Italy

Introduction: Dichloromethane (DCM) is a solvent, industrially used also as component of paint and varnish removers. Due to its high volatility, its use in confined spaces can cause a serious health hazard as a result of accumulation of the solvent vapor. At high levels, DCM acts on the central nervous system with the major toxic effects being narcosis, depression and finally, death. A case of accidental death in the work place and the DCM distribution in the victim's biological samples is described.

Methods: A 50-year-old white male was found dead at his work place. He was found supine on the edge of the tank he was cleaning without using a gas mask. The tank contained paint residuals. Autopsy findings were lung edema and emphysema, congestion of parenchymatous organs and petechial bleeding. Toxicological analyses were carried out on post-mortem samples (blood, urine, gastric contents, brain, fat, liver, lung and kidney): a systematic toxicological analysis (STA) by GC-MS for drugs and ethanol/volatile substances were detected by headspace gas chromatography (HS-GC). Dichloromethane was detected after optimization of the headspace gas chromatography-flame ionization detection technique (GC-HS-FID). Carboxyhemoglobin was measured by a spectrophotometric method.

Results: Neither drugs nor ethanol were found in the blood samples. The following concentrations of DCM were found: cardiac blood (220 mg/L), urine (25 mg/L), gastric content (22 mg/L), brain (170 mg/kg), fat (170 mg/kg), liver (250 mg/kg), lung (330 mg/kg), and kidney (160 mg/kg). The proportion of Carboxyhemoglobin in blood was 8%.

Conclusion: The cause of death was accidental poisoning with dichloromethane. Blood concentrations were in accordance with DCM levels measured in similar case reports. Postmortem distribution in organs and tissues showed concentrations higher than those reported in literature, in particular, for the lung, liver and kidney. The normal proportion of carboxyhemoglobin and the very high levels of DCM in blood suggest that death occurred rapidly as result of the direct effect of dichloromethane on the central nervous system, before significant amounts of carbon monoxide were produced by its metabolism.

Keywords: Dichloromethane, Fatal Poisoning, Postmortem Toxicology

Unnatural Death Profiling in Cyprus: A Ten Year Study (2000-2010)

M. Afxentiou, **K.Liveri***, N. Kolocassidou, M. Constantinou, K. Konari and P. Kanari
Forensic Toxicology Laboratory, State General Laboratory, Nicosia, Cyprus

Objectives: The Forensic Toxicology department of the State General Laboratory is the official department that has the authority to examine biological samples for the Republic of Cyprus. Biological samples concerning forensic and hospital cases are analyzed routinely for the detection of pesticides, blood alcohol, drugs of abuse, medicinal drugs or any other substance. This ten year study investigates the change of unnatural death profiling over this period.

Materials and Methods: Qualitative analysis was performed using HPTLC, GC/HSS/FID, GC/FID, GC/MS, Immunoassay, HPLC/PDA, GC/FPD and UV. Quantitative analysis was performed using GC/MS, GC/HSS/FID, HPLC/PDA and UV.

Results: In the period of 2000-2005 there were a total of 145 cases confirmed as unnatural deaths caused by the consumption of alcohol, drugs of abuse/medicinal drugs, pesticides. Few cases showed the presence of toxic levels of carboxyhemoglobin and were mainly due to residential exposures. Specifically unnatural deaths cases were due to pesticides poisoning 44%, high alcohol levels 10%, carboxyhemoglobin 9%, controlled drugs 24% and 13% were due to medicinal drug overdoses. In the period of 2005-2010, 220 cases of unnatural deaths were investigated: 35% were due to the abuse of controlled drugs, 12% due to pesticides, 16% - medicinal drugs, 4% - high alcohol levels, 6% - carboxyhemoglobin toxic levels. The prevalence of controlled drugs related deaths had increased, compared to the pesticides cases. According to the laboratory data, between 2000-2005 the number of drug related deaths was 32 compared to 79 over 2005-2010, while deaths due to the consumption of pesticides declined (64 to 26 cases). Medicinal drug related deaths were slightly increased. It should be noted that about 25% of the total number of cases had an unknown cause of death.

Conclusion: Cyprus is an agricultural country and pesticides were widely used up to the period of 2006. The decline of unnatural deaths due to pesticides is a consequence of the EU regulations concerning restrictions about their use. In 2004 Cyprus became a member of the EU and its social and financial status changed. Thus, controlled and medicinal drug-related deaths follow the general trends in Europe. The highest prevalence among the drugs of abuse was heroin, with 55 deaths recorded over the period of 2005-2010 compared to 25 cases over the period of 2000-2005. The most frequently encountered medicinal drugs that caused death were venlafaxine, valproic acid, citalopram, and zolpidem.

Key Words: Toxicology, Unnatural deaths, Cyprus

Influence of CYP2D6 and ABCB1 Gene Polymorphisms on the Disposition of the Enantiomers of Venlafaxine and O-Desmethylvenlafaxine in Postmortem Femoral Blood

Louise Karlsson^{1*}, Henrik Green^{1,2}, Anna-Lena Zackrisson³, Björn Carlsson¹, Martin Josefsson³, Finn Bengtsson¹, Johan Ahlner^{1,3}, Fredrik C. Kugelberg^{1,3}

¹Division of Drug Research, Clinical Pharmacology, Department of Medical and Health Sciences, Linköping University, Linköping, Sweden. ²Science for Life Laboratory, School of Biotechnology, Division of Gene Technology, Royal Institute of Technology, Stockholm, Sweden. ³Department of Forensic Genetics and Forensic Toxicology, National Board of Forensic Medicine, Linköping, Sweden

Introduction: Venlafaxine (VEN), an antidepressant, is mainly metabolized by CYP2D6 to its active metabolite O-desmethylvenlafaxine (ODV), which also is available as a separate drug in the US. P-glycoprotein (P-gp; *ABCB1/MDR1*) is a drug transporter expressed on the endothelial cells of the blood-brain barrier. Previously, we reported that VEN and its three main metabolites are actively transported out of the brain by P-gp using a mouse model [1]. Several polymorphisms in the *ABCB1* gene are known and some of them affect the activity and/or expression of P-gp, thereby influencing the treatment response and toxicity. VEN is a racemic mixture of the S- and R-enantiomers and *in vitro* these have displayed different degrees of serotonin and noradrenaline reuptake inhibition. The aim was to investigate whether polymorphisms in the *CYP2D6* and *ABCB1* genes may influence the concentrations and enantiomeric S/R ratios of VEN and its metabolites in blood from forensic autopsy cases.

Methods: The study included 116 forensic autopsy cases with different causes of deaths (mean 49±16 y; 65% men, 35% women). Enantioselective determination of VEN and its three major metabolites (O-desmethylvenlafaxine, N-desmethylvenlafaxine and N,O-didesmethylvenlafaxine) was performed in femoral blood by a liquid chromatography-tandem mass spectrometry method [2]. Genotyping for CYP2D6 (*3-*6 and gene duplications) and *ABCB1* (G1199A, C1236T, C3435T and G2677T/A) was performed with PCR followed by Pyrosequencing.

Results: A substantial variation in the relationship between the S- and R-enantiomers of parent drug and metabolites was evident (S/R ratios ranging from 0.15-18). Genotyping for *CYP2D6* revealed 8 (7.1%) poor metabolizers and 2 (1.8%) ultra rapid metabolizers. Among the CYP2D6 poor metabolizers, a low S/R VEN ratio (mean 0.55) was associated with a high S/R ODV ratio (mean 11.9). The *ABCB1* 1199 GA genotype was associated with higher ODV concentration than the GG genotype (mean 1.01 vs. 0.62 µg/g; p<0.05) and this association was primarily due to the S-enantiomer (mean 0.5 vs. 0.32 µg/g; p<0.01).

Conclusions: The strong correlation between *CYP2D6* genotype and enantiomeric VEN and ODV disposition is important since the enantiomers display different pharmacodynamic profiles. The results also suggest that *ABCB1* polymorphisms may influence blood concentrations of ODV. The latter novel finding should, however, be confirmed in future studies with larger number of cases.

References:

[1] Karlsson *et al.* 2010 Eur Neuropsychopharmacol 20:632-640 [2] Kingbäck *et al.* 2010 J Pharm Biomed Anal 53:583-590

Key Words: ABCB1, CYP2D6, Venlafaxine

Application of Enantioselective Analysis Combined with Genotyping: Implications for Interpretation of Postmortem Citalopram Levels

Fredrik C. Kugelberg^{*1,2}, Louise Karlsson², Björn Carlsson², Anna-Lena Zackrisson¹, Henrik Green^{2,3}, Finn Bengtsson², Johan Ahlner^{1,2}

¹National Board of Forensic Medicine, Department of Forensic Genetics and Forensic Toxicology, Linköping, Sweden;

²Division of Drug Research, Department of Medical and Health Sciences, Linköping University, Linköping, Sweden;

³Science for Life Laboratory, Division of Gene Technology, Royal Institute of Technology, Stockholm, Sweden

Objectives: For many substances there is no sharp dividing line between toxic and lethal drug concentrations. When drugs exist on the market as both racemates and single enantiomers the picture is even more complicated. The best way to approach this problem is to perform a drug analysis that can separate between the different enantiomers. Genotyping of genes involved in drug metabolism (e.g. *CYP2D6* and *CYP2C19*) and drug transport (e.g. *ABCB1*) have been suggested to provide insights for the interpretation of forensic toxicological results. In this study we have used a strategy to investigate pharmacogenetic factors together with enantioselective analysis of the antidepressant drug citalopram (CIT). The pharmacological activity of CIT resides in the S-enantiomer which is available as a separate drug (escitalopram; S-CIT) worldwide.

Methods: The study material included 116 postmortem cases with a wide range of causes of deaths. CIT and its main metabolite demethylcitalopram (DCIT) were determined in femoral blood by using capillary gas chromatography fitted with a nitrogen-phosphorus detector. All cases were re-analyzed using an enantioselective HPLC method with fluorescence detection. Genotyping for *CYP2D6* (*3-*6 and gene duplications), *CYP2C19* (*2-*4, *17) and *ABCB1* (G1199A, C1236T, C3435T and G2677T/A) was performed with PCR followed by Pyrosequencing.

Results: Death was related to intoxication (suicide, accident or undetermined) in 33 cases (28%). Twenty-eight cases (24%) were classified as suicides not associated with drug intoxication. The manner of death was natural in 30 cases (26%) and the remaining cases (n=25; 22%) were classified as accidents or undetermined. The mean (median) femoral blood concentrations of CIT and DCIT in all cases were 0.8 (0.4) and 0.2 (0.1) µg/g, respectively. In 17 cases (15%) no detectable levels of R-CIT were found indicating intake of the pure S-enantiomer. Eleven cases (9%) had a history of use of S-CIT, but in three of them also R-CIT was present in blood. Based on the *CYP2D6* genotype five (4%) and six (5%) individuals were classified as poor and ultra-rapid metabolizers (PMs and UMs), respectively, and the latter comprised of suicide cases. The *CYP2C19* genotype indicated five PMs (4%) and five UMs (4%). No association between drug concentrations and *ABCB1* polymorphisms was found.

Conclusions: The present results emphasize the importance of using enantioselective analysis of CIT as a supplementary tool in forensic case work. Without access to such a method a CIT level at the upper limit of the therapeutic range could cause an underestimation of the true concentration if only escitalopram (S-CIT) has been taken. The prevalence of *CYP2D6* UMs was higher than expected in a Caucasian population. The cause of death among those six cases was suicide and the implication of this finding needs to be further scrutinized.

Key Words: Citalopram, Enantiomers, Genotyping

The Use of Pharmacogenetic Analysis in Forensic Toxicology - Relation Between *CYP2D6* Genotype and Ethylmorphine/Morphine Ratios in Post Mortem Blood

Anna-Lena Zackrisson*¹, Gunilla Thelander¹, Robert Kronstrand¹, Johan Ahlner¹

¹National Board of Forensic Medicine, Department of Forensic Genetics and Forensic Toxicology, Linköping, Sweden

Objectives: Ethylmorphine is an opiate used as an antitussive in cough syrup. Ethylmorphine is metabolized to morphine by the liver enzyme CYP2D6. Morphine is then glucuronidated by the uracil glucuronidase UGT2B7. The aim of this study was to investigate if polymorphism in the *CYP2D6* gene could explain unusual ethylmorphine/morphine ratios in autopsy cases. In most people ethylmorphine is metabolized to morphine, although only to a minor extent and ratios much greater than 1 are typical. Our hypothesis originated from a case in which a pregnant woman died following an acute overdose of opioids and the fetus had an ethylmorphine/morphine ratio of 0.11. The mother was found to be a carrier of multiple gene copies, *CYP2D6*1xN/*1* corresponding to the phenotype of an ultra-rapid metabolizer (UM).

Materials and Methods: During a 12 month period all autopsy cases positive for ethylmorphine and where morphine was detected in femoral blood were collected and subjected to pharmacogenetic analyses (n=24, 12 men and 12 women, mean age 52 year). DNA was extracted and genetic variations in *CYP2D6* (*3-*6 and gene duplications) were identified by PCR followed by Pyrosequencing.

Results: The cases were divided into two groups, those above (A) and below (B) the therapeutic level of 0.3 mcg ethylmorphine/g blood. Additional drugs were detected in all cases with a mean number of 5.4±2.5 and 5.1±2.9 drugs identified in each case from group A and B, respectively. Group A comprised of nine intoxication cases (two suicides, three accidents and four undetermined) and two cases not associated with intoxication (e.g. hanging). In group B, 12 of 13 deaths were natural and one classified as accidental. The number of active *CYP2D6* gene copies (e.g. the possibility to metabolize) in the subjects of group A were one case carrying no copy, corresponding to a poor metaboliser (PM), three cases carrying one copy, six cases carrying two copies and one case carrying more than two copies (UM). Group B included five cases carrying one copy, seven cases carrying two copies and one case carrying more than two copies. Codeine was detected in three cases and both codeine and 6-acetylmorphine were present in another. These four samples were excluded from the following calculations (one from group A and three from group B) because codeine and 6-acetylmorphine also produce morphine and the concentration of morphine may be elevated in these cases. With codeine present, these elevated concentrations depend on the *CYP2D6*, while the hydrolysis of 6-acetylmorphine to morphine is independent of *CYP2D6*. The mean concentration (mcg/g blood) of ethylmorphine and morphine in group A was 1.06±1.17 and 0.14±0.13, compared with 0.13±0.06 and 0.06±0.06 in group B, respectively. The mean ethylmorphine/morphine ratio was 14.3±13.8 in group A and 4.1±4.2 in group B. No correlation between the ethylmorphine/morphine ratio and the number of active *CYP2D6* gene copies was found in any of the groups.

Conclusion: There was a large inter-individual variation in the ratio of ethylmorphine/morphine in forensic autopsy cases. This variation could not only be explained by different *CYP2D6* genotypes. Intake of drugs such as codeine, morphine and heroin will affect the metabolic ratio while other drugs can interact and/or inhibit the CYP2D6 enzyme. Another confounding factor is that we do not know the time between drug intake and the death. We believe that it is important to evaluate how different factors could have influenced each specific case and that genotyping may be valuable in some cases.

Key Words: Ethylmorphine, CYP2D6, Pharmacogenetic

Vitreous Humor as an Alternative Matrix in Forensic Toxicology**Bertrand Brunet***, Yves Papet, and Patrick Mura

Laboratoire de Toxicologie et Pharmacocinétique, Centre Hospitalier Universitaire, Poitiers, France

Introduction: Vitreous humor was extensively used over the last decades in forensic toxicology. Primary investigations focused on biochemical markers of post-mortem interval. For this purpose, the role of potassium for determining time since death has been widely investigated. In toxicology, vitreous humor was used mainly for ethanol determinations and more recently, in studies focusing on drug determinations and correlation of concentrations with other matrices.

Objectives: Our goal was to establish different cases where vitreous humor may be useful in forensic toxicology. Previous studies were referenced to know which drugs (licit or illicit) can or cannot be detected. Vitreous humor is a biofluid well-preserved after death from any contamination or post-mortem redistribution, but the rate of distribution can vary greatly between drugs. Opiates, amphetamines and benzodiazepines were the most frequently studied drugs in vitreous humor. Here, we discuss the results obtained in different studies and describe cases analyzed in our laboratory where vitreous humor results were useful for case interpretation.

Methods: Vitreous humor was screened for unknown compounds by liquid chromatography-diode array detection (LC-DAD), analyzed for cannabinoids by gas chromatography-mass spectrometry (GC-MS), used for alcohol determinations with headspace GC-flame ionization detection (FID) and analyzed for amphetamine, cocaine, opiates and multi-targeted screening by liquid chromatography tandem mass spectrometry (LC-MS-MS). For glucose determinations a photometric assay was used.

Results: Literature is available on diffusion and analysis of most drugs of abuse in vitreous humor. 3,4-Methylenedioxymethamphetamine (MDMA) and 3,4-methylenedioxyamphetamine (MDA) are well detected in vitreous humor with no postmortem changes. Opiates poorly distribute into vitreous humor, but the half-life of 6-monoacetylmorphine (6-MAM) was reported to be longer in vitreous humor than in blood. Additionally, morphine can be detected and we illustrate its interest with a case of a deceased embalmed female. Blood sample quality was questioned and morphine concentration in vitreous humor (374 ng/mL) helped to ascertain the cause of death as a morphine overdose. Cocaine and benzoylecgonine can be found in vitreous humor. On the contrary, cannabinoids are not detectable in vitreous humor. This was confirmed in animals and humans. Ethanol determination is the most common use for vitreous humor. It can help to determine in which phase (absorption or elimination) the death occurred by comparing with a blood ethanol concentration. Vitreous humor is also useful in cases of stomach rupture, where the blood may become contaminated. We illustrate this with a case where a substantial difference was found between blood (0.28 g/dL) and vitreous humor (0.03 g/dL).

Conclusion: Vitreous humor has advantages over other matrices in terms of stability and it is relatively exempt from postmortem redistribution. However, interest is limited by the lack of data for most drugs. Literature is scarce on diffusion of prescription medicines in vitreous humor and interpretation of concentrations in the absence of references is difficult. Toxicologists should be encouraged to analyze vitreous humor and publish their results.

Key Words: Vitreous Humor, Forensic Toxicology, Alternative Matrices

Evaluation and Comparison of Neogen[®] Corporation's Methadone / LAAM ELISA Kit with Postmortem Specimens**Brian Simons*** and Laureen Marinetti

Montgomery County Coroner's Office/Miami Valley Regional Crime Laboratory, Dayton, Ohio, USA

Introduction and Objectives: Located in Dayton, Ohio, the Montgomery County Coroner's Office provides full toxicological testing for nearly half of Ohio's 88 counties. Full toxicology testing includes screening for volatiles and drugs of abuse, prescription medication screening by gas chromatography / mass spectrometry (GC/MS), and subsequent confirmation testing. One commonly prescribed medication routinely detected in Coroner's Office casework is methadone (Methadose[®], Dolophine[®]). Methadone is a long lasting synthetic opioid that possesses analgesic properties and is commonly prescribed for the management of chronic pain as well as treatment of heroin addiction. Recently, Neogen[®] Corporation released a kit with improvements for the detection of methadone in biological matrices. The purpose of this study was to compare the sensitivity and response of Neogen's[®] original methadone kit with that of the new methadone / levo- α -acetylmethadol (LAAM) kit.

Materials and Methods: This evaluation was performed with postmortem samples retained at the Montgomery County Coroner's Office over the previous year. The screening process for prescription medication, including methadone, involved a liquid-liquid extraction by the Basic Forester method, reconstitution with ethyl acetate, and injection on an Agilent 6890 GC/MS. Confirmation testing of methadone involved a liquid-liquid extraction using a hexane/isoamyl alcohol solution, reconstitution in toluene/isoamyl alcohol, and injection on a gas chromatograph utilizing a nitrogen-phosphorus detector (GC-NPD). Confirmed cases were then subjected to ELISA screening with Neogen's[®] methadone and methadone/LAAM kits. Testing was performed with a Tecan[®] MiniPrep automated system and Magellan[®] software. Two positive controls were used: a 25 ng/mL control in synthetic human urine supplied by Neogen[®] and 50 ng/mL in-house control spiked in blank blood matrix.

Results and Discussion: For this study, 101 samples ranging in concentration from less than 50 to 4000 ng/mL were used. Only one case was excluded due to extreme deviation from the entire data set. Comparison of the old and new kit yielded no significant variation in sensitivity. This was demonstrated by plotting percent binding response of the old kit versus the new and achieving a correlation coefficient of 0.93. Percent binding for each kit was calculated by averaging raw data values from cases lacking the presence of methadone (n=12) and comparing it to the raw data value for each case. Testing of cases lacking the presence of methadone indicated that matrix effects may be more prevalent with a less diluted sample; however, at concentration levels as low as 30 ng/mL (n=2) there is still enough differentiation to discern a positive from negative result. More importantly, the methadone/LAAM kit's dilution scheme is consistent with other Neogen[®] products. This allows for multiple panels of analytes to be screened without losing sensitivity and maintaining minimal variation in preparation work. Cross-reactivity with other analytes did not appear to be an issue with either kit. Because the Coroner's Office does not confirm LAAM, a highly cross-reactive analyte with each kit, its contribution to positive screening could not be ruled out. However, due to LAAM's discontinued usage in the United States since 2003, it is highly unlikely that it was present in any casework. With methadone's common appearance in many toxicological settings, this new and improved screening kit will benefit forensic as well as clinical labs to better and more efficiently identify this analyte of interest.

Key Words: Methadone, ELISA, Postmortem

Distribution of the Inhalant 1, 1-Difluoroethane (HFC-152a) in the Rat**Hiroshi Ochi**^{*1}, Takeshi Hayashi¹, Ryoji Matoba¹ and Kazuo Igarashi^{1,2}¹Department of Legal Medicine, School of Medicine, Osaka University, Suita, Osaka, JAPAN; ²Association of Medicinal Analysis, Amagasaki, Hyogo, Japan

Introduction: 1,1-Difluoroethane (HFC-152a) is a halogenated aliphatic compound and is commonly used as an air duster for blowing dust off electric devices and other sensitive equipment. Apart from normal use as a cleaning product, it is also used among people to induce euphoria by inhaling the gas component. The reports of sudden death associated with this abnormal use have increased.

Objectives: To determine tissue distribution of the inhalant HFC-152a in rats and to search for a cause of sudden death following inhalant exposure of HFC-152a.

Materials and Methods: The inhalant exposure study was conducted using male Wistar rats (about 250 g). HFC-152a delivery was accomplished using an apparatus that feeds gas to a dynamic exposure chamber containing an animal (chamber = 500 cm³). The inhalant gas used was a mixed one which consisted of 75% HFC-152a and 25% oxygen. Animals were exposed to 20s of 3L/min gas. Animals were sacrificed under carbon dioxide and then blood and tissue samples were collected. Two hundred mg of each sample was placed into a headspace vial, which was sealed. Each vial was heated at 70°C for 20 min, and then 100 µL of the headspace was injected into a Shimadzu QP-5050 gas chromatography-mass spectrometry (GC-MS) equipped with a CP-PoraBOND Q fused silica column (25 m x 0.25 mm, i.d., thickness 3.0 µm). A quantitative determination for HFC-152a was undertaken using a selected ion monitoring (SIM) with m/z 51, a fragment ion of HFC-152a (MW = 66) and m/z 69, a fragment ion of internal standard, 2,2,2-trifluoroethanol (MW = 100).

Results: Blood and tissue levels of HFC-152a were determined at 0, 10, 30 and 60 min after inhalant exposure. Except for fat tissue, blood and other tissue levels decreased immediately. HFC-152a concentration in fat tissue decreased gradually and the level at 30 min was approximately 1/2 less than at 0 min. Blood level at the same time was roughly 1/20 less than at 0 min. On the other hand, blood and tissue levels in rats sacrificed and let stand for 10 and 30 min were generally constant.

Conclusion: HFC-152a is eliminated immediately by exhalation and HFC-152a levels in blood and tissues following sudden death are constant. Therefore, sudden death following inhalant exposure of HFC-152a does not result from chemical toxicity and may be caused by asphyxiation.

Key Words: HFC-152a, Distribution, Inhalant Exposure

P156

Cocaine, Metabolites and Derivatives in Vitreous Humor Using Disposable Pipette Extraction Tips and Gas Chromatography-Mass Spectrometry

Mariana Dadalto Peres*¹ and Bruno Spinosa De Martinis²

¹Faculty of Pharmaceutical Sciences of Ribeirão Preto - USP, Ribeirão Preto, SP, Brazil; ²Department of Chemistry, Faculty of Philosophy, Sciences and Literature of Ribeirão Preto - USP, Ribeirão Preto, SP, Brazil

Objectives: The aim of this work is to develop a simple and fast method for quantification of cocaine (COC), benzoylecgonine (BE), cocaethylene (CE) and anhydroecgonine methyl ester (AEME) in vitreous humor using disposable pipette extraction tips and gas chromatography-mass spectrometry (GC/MS).

Methods: 200 μ L of vitreous humor was mixed with 50 μ L of 0.1 M HCl and deuterated internal standard, then extracted using disposable pipette extraction tips with cation-exchange (CX) resin (DPX Labs, USA). The wash solvent consisted of 500 μ L of distilled water and the elution solvent consisted of 500 μ L of 78/20/2 of CH₂Cl₂/isopropanol/ammonium hydroxide for elution of the drugs. After elution of the analytes, the solution was evaporated, reconstituted and derivatized with 50 μ L MSTFA and analyzed by GC/MS.

Results: COC, BE, CE, and AEME were successfully extracted from vitreous humor using DPX Lab's procedure and analyzed by GC/MS. Calibration curves for all the analytes studied were linear over the concentration range 50-2500 ng/mL. The %CV ranged from 11% to 20%. This extraction method gave clean chromatography and the GC/MS method could achieve limits of detection up to 10 ng/mL and recoveries ranged from 15 to 32%.

Conclusion: Despite the poor recovery that could be improved, the proposed method was efficient in identification and quantification of cocaine, metabolites and derivatives in vitreous humor samples. Subsequent experiments performed in our research group showed an improvement in the recovery up to 70% for the same analytes by using two consecutive elutions with 500 μ L elution solution.

Key words: Vitreous Humor, Disposable Pipette Extraction (DPX), Cocaine

Alcohol in Fatal Traffic Accidents in Espírito Santo, Brazil

Josidéia Barreto Mendonça¹, Jauber Fornaciari Pissinate¹, Daniela Mendes Louzada de Paula¹, **Mariana Dadalto Peres^{2*}** and Fabricio Souza Pelição¹

¹Police of Espírito Santo, Laboratory of Forensic Toxicology, Vitoria, ES, Brazil; ²Faculty of Pharmaceutical Sciences of Ribeirão Preto - USP, Ribeirão Preto, SP, Brazil

Objectives: The aim of this study is to correlate alcohol levels detected in drivers of fatal traffic accidents, in the Espírito Santo metropolitan area, with victim profiles and accident characteristics in 2010.

Materials and Methods: Drivers involved in fatal crashes in the metropolitan area were identified during 2010 (n=170) and the whole blood alcohol concentration (BAC) was determined using headspace gas chromatography with flame ionization detection (GC-FID). The data were retrieved from the registers of the Legal Medicine Department/DML and the Espírito Santo's traffic station.

Results: In 2010, of the 170 drivers that died from traffic accidents, only 8 were female. Of the 41.3% positive BAC, 6.7% were less than 6.0 dg/L, 15.0% were between 6.1 and 10.0 dg/L, 55% ranged from 10.1 to 20.0 dg/L, 20.0% were between 20.1 and 30 dg/L, 1.7% were between 30.1 and 40.0 dg/L and 1.7% were higher than 40.1 dg/L. Forty percent of the drivers involved in accidents were 18-30 years old, 26.9% were 31-40, 17.9% were 41-50 and 15.2% were older than 51 years. Those between 31-40 years old had the highest incidence of positive BAC (53.8% of drivers of that age group). Most accidents (56.2%) occurred during the weekend and alcohol was involved in 52.4% of these cases. The types of vehicle driven during the accident were cars (41.7%), motorcycles (53%), and trucks (5.3%).

Conclusion: Nearly half of the drivers involved in accidents had a BAC above the limit in Brazilian law (2 dg/L). The data shows that more surveillance is needed for drivers aged 31-40 years and on the weekend due to the increased number of positive BAC drivers.

Key Words: Drivers, Alcohol, Traffic Accidents

Enzyme-Linked Immunosorbent Assay (ELISA) Analytical Performance Validation for the Detection of 20 Drug Categories in Human Performance and Post-Mortem Blood

Ginger L. Baker *, Amy J. Goedert , and Rong-Jen Hwang

Toxicology Bureau, Scientific Laboratory Division (SLD), Department of Health, State of New Mexico, Albuquerque, NM, USA

Objective: The objective was to validate the analytical performance of a method for the rapid screening of ante-mortem and post-mortem blood specimens by ELISA for the determination of acetaminophen, barbiturates, benzodiazepines, carisoprodol, cocaine, fentanyl, fluoxetine, hydrocodone, meperidine, methadone, methamphetamine, opiates, oxycodone, propoxyphene, salicylates, sertraline, THC, tramadol, tricyclic antidepressants and zolpidem.

Method: The drug categories were chosen based on the most frequently reported drugs identified by GCMS in the SLD Toxicology Bureau Laboratory. Target drugs were used to determine the analytical performance in terms of dose-response, limits of detection (LOD), precision, binding characteristics (effective concentration at 50% EC₅₀) and carryover. Proposed cutoff values were chosen based on SLD casework, known therapeutic drug ranges and recommendations of the American Board of Forensic Toxicology. Binding curves at proposed cutoff values were evaluated with all kits at sample:phosphate buffer diluent ratios ranging from 1:2 through 1:20 using the Dynex DSX analyzer. The kits selected were originally validated by three different manufacturers using body fluids including whole blood, plasma, serum, urine and saliva. Additional commercial kits were validated for benzodiazepines, cocaine, meperidine, methamphetamine, oxycodone, tramadol and tricyclic antidepressants in order to identify acceptable binding curves for these drug categories. The LOD was calculated from the mean response of the blank (n=8) minus three standard deviations and precision was evaluated by replicate analysis of drug fortified blood (n=4) in the range of 0.25 – 32 ng/mL for fentanyl, 1 – 200 µg/mL for acetaminophen and salicylate and 4 to 1000 ng/mL for the other 17 drug categories. Carryover was determined statistically by comparison of mean negative controls measured before and after samples containing elevated concentrations of drug. An 18 drug standard mixture was used to fortify blank blood to determine % binding for all drugs except acetaminophen and salicylate. The effective concentration for 25%, 50% and 75% binding at the proposed cutoff were calculated using the logistical equation: $y = A2 + (A1-A2)/(1 + (x/x_0)^p)$ (non-linear fit). Ante-mortem and post-mortem blood samples were analyzed by GCMS for negative and positive rates in order to establish Receiver Operator Characteristics at each proposed cutoff for the 1:20 dilution.

Results: The manufacturers' recommended sample volumes were adjusted for all drug panels except benzodiazepines, carisoprodol, fluoxetine, hydrocodone, methamphetamine and sertraline. The 18 panel drug mixture lowered the percent binding for several drugs due to cross-reactivity. Precision at the cutoff using the 1:20 dilution ranged from 1.5 to 12.3. Carryover was detected at 5000 ng/mL for the cannabinoids ELISA kit. Binding curves and EC data will be presented for each dilution. The % binding at 1:20 dilution ranged from 31% for benzoyllecgonine to 67% for tramadol.

Conclusions: The 1:20 sample dilution ratio was the most suitable for the analysis of drugs in antemortem and post-mortem blood for the 20 drug categories. This ratio was used in the next part of the validation study that will be presented at this meeting: casework performance to determine actual cutoff concentrations.

Key Words: ELISA, Blood, Analytical Validation

Enzyme-Linked Immunosorbent Assay (ELISA) Casework Performance Validation for the Detection of 20 Drug Categories in Blood

Gerasimos Razatos *, Ginger L. Baker, and Rong-Jen Hwang

Toxicology Bureau, Scientific Laboratory Division, Department of Health, State of New Mexico, Albuquerque, NM, USA

Objective: Casework performance was evaluated using an ELISA screening method for the determination of acetaminophen, barbiturates, benzodiazepines, carisoprodol, cocaine, fentanyl, fluoxetine, hydrocodone, meperidine, methadone, methamphetamine, opiates, oxycodone, propoxyphene, salicylates, sertraline, THC, tramadol, tricyclic antidepressants and zolpidem in blood. ELISA and GC/MS results were compared in order to obtain negative and positive rates at the proposed cutoff and at three other values near the cutoff for each drug category. Receiver operating characteristic curves (ROC) were established for each drug value tested. The ROC curves and the analytical performance data from the previous study were used to identify the most suitable cutoff concentration for each drug category.

Method: Randomly selected blood samples totaling 386 were screened at four potential cutoff concentrations using a 1:20 sample:phosphate buffer diluent ratio and the experimentally derived sample aliquot. Of these, 202 were human performance cases and 184 were post-mortem cases. GC/MS was used to confirm the presence of drugs in each sample. Negative and positive rates were established for the samples at each concentration. Sensitivity, specificity, false positive, false negative, positive predictive value and negative predictive value were calculated. ROC curves were plotted as sensitivity over specificity.

Results:

	Proposed Cutoff ng/mL	True Positive	True Negative	False Positive	False Negative
Acetaminophen	10,000	28	17	0	5
Secobarbital	200	16	58	0	7
Nordiazepam	25	35	41	0	5
Carisoprodol	500	29	50	2	3
Benzoyllecgonine	50	27	45	0	6
Fentanyl	1	25	71	0	3
Fluoxetine	500	27	70	1	3
Hydrocodone	50	21	56	16	8
Meperidine	250	1	90	1	9
Methadone	50	19	81	0	3
d-Methamphetamine	50	24	44	0	9
Morphine	50	26	67	7	3
Oxycodone	50	18	73	0	12
Propoxyphene	50	35	83	1	0
Salicylic Acid	25,000	15	28	0	7
Sertraline	100	30	88	1	0
THCA	25	31	79	0	4
Tramadol	100	23	28	0	7
Nortriptyline	100	23	85	3	8
Zolpidem	25	27	29	0	2

Conclusions: Sensitivity was very poor for the four meperidine concentrations tested. Initial review of the data identified optimal ROC curves below the proposed cutoff value for acetaminophen, benzoyllecgonine, hydrocodone, methadone, methamphetamine, oxycodone and tramadol. The data from this study were further evaluated with the analytical performance data to identify the final cutoff concentration for casework at the Toxicology Bureau Laboratory.

Key Words: ELISA, Blood, Casework Validation

Enzyme-Linked Immunosorbent Assay (ELISA) Validation for Positive Cutoff Concentrations of 20 Drug Categories in Human Performance and Postmortem Blood Samples

Rong-Jen Hwang*, Protiti Sarker, and Ginger L. Baker

Toxicology Bureau, Scientific Laboratory Division, Department of Health, State of New Mexico, Albuquerque, NM, USA

Objectives: Final ELISA positive cutoff concentrations were selected using analytical and casework performance data for acetaminophen, barbiturates, benzodiazepines, carisoprodol, cocaine, fentanyl, fluoxetine, hydrocodone, meperidine, methadone, methamphetamine, opiates, oxycodone, propoxyphene, salicylates, sertraline, THC, tramadol, tricyclic antidepressants (TCA) and zolpidem in blood.

Methods: Sample volume of 1:20 diluted blood, binding curves, half maximal effective concentration (EC_{50}) data and receiver operating characteristic (ROC) plots were evaluated for each drug category. In addition, historical casework drug results, limits of quantitation of current GC/MS methods and therapeutic ranges were also considered in determining the final cutoff for each drug.

Results:

	Proposed Cutoff ng/mL	Proposed Cutoff % Binding	Final Cutoff ng/mL	Final Cutoff % Binding	Initial Sample Volume (uL)	Final Sample Volume (uL)
Acetaminophen	10,000	51	10,000	51	20	50
Secobarbital	200	62	200	62	50	90
Nordiazepam	25	38	25	52	25	25
Carisoprodol	500	42	500	42	10	10
Benzoyllecgonine	50	31	50	32	50	80
Fentanyl	1	41	1	42	20	50
Fluoxetine	500	53	500	40	100	100
Hydrocodone	50	56	25	65	20	20
Meperidine	250	51		45	20/10	40
Methadone	50	44	50	48	25	10
d-Methamphetamine	50	37	25	34	20	20
Morphine	50	44	50	49	25	10
Oxycodone	50	48	25	32	10	25
Propoxyphene	50	48	50	66	15	50
Salicylic Acid	25,000	44	25,000	57	10	20
Sertraline	100	53	100	54	100	100
THCA	25	30	25	46	25	10
Tramadol	100	67	100	36	10	100
Nortriptyline	100	50	100	45	25	10
Zolpidem	25	42	25	42	20	50

Conclusions: Percent binding at the final cutoff ranged from 32% to 66% for the 20 drug panels. OraSure Methamphetamine and Cocaine kits demonstrated poor %binding reproducibility; therefore, Immunalysis kits were reevaluated at a 1:20 dilution for these drugs. Orasure and Immunalysis benzodiazepine kits were compared at a 1:20 dilution and ROC curves were determined using both kits; both kits performed well. Immunalysis and IDS kits were compared at a 1:20 dilution for carisoprodol, meperidine, oxycodone, tramadol and TCA. Immunalysis kits for carisoprodol, meperidine, oxycodone, tramadol and TCA were selected for the casework performance study. However, meperidine demonstrated poor sensitivity and a high false negative rate and was omitted from the laboratory's drug screen.

Key Words: ELISA, Blood, Cutoffs

Contribution of Alcohol and Drugs to Fatal All-Terrain Vehicle Accidents in West Virginia

Kristen M. Bailey*, Lauren L. Richards-Waugh, Myron A. Gebhardt, David J. Clay, Christina L. Newsome-Sparks, James A. Kaplan, and James C. Kraner.

Office of the Chief Medical Examiner, Charleston, WV, USA

Objectives: Characteristics such as demographic and socioeconomic trends, use of safety equipment, time of year, and contribution of impairment from alcohol as they relate to fatal all-terrain vehicle (ATV) accidents in West Virginia have been described in previous reports. In addition to alcohol-related impairment, this study addresses the contributory role of illicit and pharmaceutical drugs, with a highlight on the presence of controlled pharmaceuticals without documented prescription access.

Materials and Methods: In 2009 and 2010, 66 fatal ATV accidents were investigated by the West Virginia Office of the Chief Medical Examiner. Blood specimens from 64 of these cases were analyzed and the concentrations of ethanol and drugs of abuse were determined.

Results: Ethanol alone was found in 36% of cases, 14% were positive for drugs only, and 23% of cases were positive for both ethanol and drugs. While pharmaceutical drugs were encountered in 19 of the 64 cases, prescription access could be confirmed in only four cases. Ethanol concentrations ranged from 0.04 to 0.53% with an average of 0.19%. Ethanol concentrations exceeding 0.08% were found in half the cases. Hydrocodone was the most commonly detected pharmaceutical drug, being found in seven cases with concentrations ranging from less than 0.01 to 0.30 mg/L. Oxycodone was found in three cases with concentrations ranging from 0.08 to 0.53 mg/L. Marijuana metabolites were the most commonly detected illicit substances (five cases) followed by cocaine metabolites (three cases).

Conclusions: This study emphasizes that alcohol and drug-related impairment should be intently examined as a potential contributing factor to fatal ATV accidents. Furthermore, it illustrates the alarming frequency of pharmaceutical misuse and diversion among a group of people involved in an inherently risky activity.

Keywords: ATV, Fatality, Impairment

Simultaneous Determination and Quantification of Nine Opioids in Blood, Plasma, and Tissue Homogenates Using Methoxyamine/MSTFA Dual Derivatization and Mini-Bore Fast GC/MS-EI SIM

Daniel D Baker*, Calvin E McGuire, and Jan M Gorniak
The Office of the Franklin County Coroner, Columbus, OH, USA

Objectives: The authors present a validated method for the analysis of 6-monoacetylmorphine (6-MAM), morphine, codeine, hydrocodone, dihydrocodeine, hydromorphone, oxycodone, oxymorphone, and naloxone.

Materials and Methods: Simultaneous opioid analysis by GC/MS has been historically problematic because traditional GC columns have often been unable to resolve complex opioid mixtures; the analysis of some opioids as the underivatized free base have not yielded optimal sensitivity; and oxycodone, oxymorphone, hydrocodone, hydromorphone, and naloxone contain a ketone functional group undergoing keto-enol isomerism, resulting in multiple derivatized species. To remedy these problems, the authors employed a simple solid phase extraction (SPE), followed by the application of a two step derivatization process using methoxyamine and MSTFA, and final analysis with a GC/MS equipped with a 10 meter, 0.18 mm I.D. 50% phenyl mini-bore capillary column. Total run time was 6.8 min. To the authors' knowledge, this is the first application and presentation of this combination of derivatization reagents applied to whole blood, plasma, and tissue homogenates for simultaneous opioid analysis.

Opioids were grouped dependent upon expected therapeutic, toxic, and lethal blood concentrations. Calibrator reference standards were obtained from Cerilliant, and QC reference standards were obtained from Grace. Deuterated internal standards (IS) were included if available, and obtained from Cerilliant. Working calibrator, QC, and IS solutions were prepared in acetonitrile. 2 mL whole blood was fortified with the appropriate volume of working IS, and calibrator or QC. The specimens were buffered to pH 6.0 and subjected to SPE using United Chemical Technology #ZSDAU020 columns and general opiate extraction method. Eluents were dried at <40°C under N₂. 30 µL of 2% methoxyamine HCl in pyridine was added; tubes were capped and incubated at room temperature for 15 min. Pyridine was evaporated at 35°C under N₂. Dried residues were reconstituted with 50 µL of ethyl acetate and 50 µL of MSTFA w/ 1% TMCS, tubes were capped and incubated at ~70°C for 20 min. 1 µL was injected into an Agilent 5975 GC/MS equipped with a Zebron® ZB-50, 10 m + 2 m guard, 0.18 mm I.D, 0.18 µm df, #7CD-G004-08-GGT-C. Ions were collected for the following compounds and their representative deuterated IS: morphine-di-TMS, dihydrocodeine-TMS, codeine-TMS, oxymorphone-methoxyimino-di-TMS, naloxone-methoxyimino-di-TMS, hydromorphone-methoxyimino-TMS, 6-MAM-TMS, oxycodone-methoxyimino-TMS, and hydrocodone-methoxyimino.

Results: Method validation studies demonstrated a linear range of the high opioids from 20-800 ng/mL, and low opioids from 10-400 ng/mL. Linearity (n=11) for all analytes ranged from an R² of 0.998-1.000. Limits of detection were experimentally determined and ranged from 2.5-10 ng/mL. Accuracy and imprecision (n=6 x 3 QC levels) ranged from -1.0% to +7.2% error and 0.6% to 7.4% CV. Extraction efficiency ranged from 95.2% - 97.6% recovery. Extract stability at 72 hrs on the GC/MS auto-sampler tray ranged from -2.1% to +9.1%. No extraneous compounds were found to affect the specificity of the analysis.

Conclusion: The application of this procedure resulted in faster analysis times, increased number of opioids detected and quantified, increased sensitivity, improved chromatographic resolution, and faster case turnaround time. Complete GC/MS methods, S.O.P.s, and validation data will be available on CD for dissemination.

Key Words: Opioids, Methoxyamine, Methoxyimino

Strychnine - A Fatal Case in the UK

Gemma Coombes, **Malgorzata Puchnarewicz***, Verity Hayward, David W Holt and Atholl Johnson
Analytical Unit, St George's – University of London, London, UK

Case History: A 40 year old man was found dead with a number of unmarked pink tablets close by. He had not been seen for 7 days. An overdose was suspected as the cause of death. A full toxicological analysis was carried out at the Analytical Unit. Liver and urine were the only specimens available; the tablets were not submitted for analysis. Strychnine was not suspected in this case but detected during routine screening. Strychnine is a natural alkaloid occurring in the seeds of *strychnos nuxvomica* and *strychnos ignatii*. Historically, strychnine has been used medically and with homicidal and suicidal intent. Restricted availability has reduced the occurrence of intentional or accidental poisoning, but it has been observed as a contaminant in illicit drugs. Its use is prohibited by the European Union although it is still in use in some Middle Eastern and other countries. Rodenticides containing strychnine and strychnine tablets are available to purchase via the Internet.

Materials and Methods: Strychnine and flurazepam were obtained from Sigma Aldrich, 40% sodium hydroxide and 80% phosphoric acid from BDH and MTBE from Rathburn. Strychnine calibrators were prepared in the range of 0-10 mg/L. A basic liquid-liquid extraction method was used. A Shimadzu GC/MS-QP 2010 GC/MS equipped with an electron ionization ion source utilizing positive ionisation was used for detection. The initial column temperature was set at 80°C and held for 4 minutes. It was then ramped at 20°C/minute and held for 18 minutes at 290°C, with a total run time of 30.6 minutes. The method was run in SIM mode and set to detect m/z 334.00 for strychnine and m/z 86.00 for flurazepam. The carrier gas was helium.

Results: 5.1 mg/kg of strychnine was detected in the liver and 7.3 mg/L in urine. Concentrations in the liver associated with death are in the range 2-257 mg/kg. The minimum lethal dose is 50 – 100 mg for adults. Ethanol was detected in the urine at a concentration of 42 mg/100mL, but no other drugs were detected.

Conclusion: The concentration of strychnine was found to be within the range associated with fatalities. No other drugs of significance were detected.

Key Words: Strychnine, Tablets, Liver

Fatal Drug Intoxications Involving Oxymorphone

Myron A. Gebhardt*, David J. Clay, Kristen M. Bailey, Lauren L. Richards-Waugh, Christina L. Newsome-Sparks, Nabila A. Haikal, and James C. Kraner
Office of the Chief Medical Examiner, Charleston, WV, USA

Objectives: Oxymorphone is a high potency semi-synthetic opioid analgesic prescribed for the relief of moderate to severe pain. Therapeutic use of oral oxymorphone preparations typically results in peak peripheral blood concentrations <10 ng/mL. Subsequent to the 2006 FDA approval of immediate and extended-release formulations of the drug, the Office of the Chief Medical Examiner (OCME) Charleston, WV saw a dramatic increase in oxymorphone-related deaths. The purpose of this study is to present toxicological findings from fatalities involving oxymorphone investigated by the OCME from 2009 through early 2011.

Materials and Methods: Case specimens obtained at autopsy were screened for alcohol by gas chromatography flame ionization detection (GC-FID) and for drugs using immunoassay and/or liquid chromatography time of flight mass spectrometry (LC/TOF/MS). Oxymorphone confirmation and quantitation in peripheral blood was performed using LC/MS/MS with a 2 ng/mL limit of quantitation.

Results: In 2009, the OCME investigated 17 deaths in which oxymorphone was deemed contributory to fatal overdose, with the number of oxymorphone-related fatalities increasing to 41 in 2010. Oxymorphone was present in 19 cases of fatal drug intoxication certified by the OCME during the first quarter of 2011. Six deaths attributed solely to oxymorphone intoxication were found to have blood concentrations ranging from 16.6 to 160 ng/mL (mean 119 ng/mL). The majority of oxymorphone-related fatal overdoses involved several other drugs and/or alcohol that were judged to be contributory. In these deaths, oxymorphone concentrations ranged from 9 to 360 ng/mL (n= 51, mean 85 ng/mL).

Conclusions: When both oxycodone and oxymorphone are detected, the presence of the oxymorphone metabolite at a concentration <10% of the oxycodone concentration is generally consistent with oxycodone use. During 2009 and 2010, the OCME encountered a considerable number of fatal overdoses involving both oxycodone and oxymorphone. The exclusion of oxycodone-positive cases was deemed appropriate in this study because the relative contribution of oxycodone metabolism to the oxymorphone concentration could not be accurately assessed.

Preliminary assessment of the overall death investigation findings in these oxymorphone-related fatalities suggests that a substantial proportion of these deaths may be attributed to a misunderstanding of oxymorphone's potency and its inherent risk when abused in a recreational setting (ie. snorting, injecting, etc.).

Key Words: Oxymorphone, Intoxication, Postmortem

Heroin Overdose and Myocardial Damages: The Relationship Between Toxicology and Immunohistochemistry Investigations in 95 Cases

Francesco P. Busardò*¹, Emiliano Maresi¹, Antonella Argo¹, Katia Guerrini², Veniero Gambaro², Paolo Procaccianti¹

¹Department of Biopathology, Medical and Forensic Biotechnology, Section of Legal Medicine, University of Palermo, Italy;

²Department of Pharmaceutical Sciences "P. Pratesi" - Laboratory of Chemical Toxicology, University of Milan, Italy

Objectives: There are many known cardiac effects related to chronic drug use, such as heart failure, myocardial infarction, aortic dissection, endocarditis, myocarditis and fibrosis. However, these conditions are not always correlated with morphine concentrations in antemortem or postmortem biological fluids. The specific aims of this study were to identify moderate heart inflammation in heroin overdose cases utilizing toxicological and immunohistochemical staining.

Materials and Methods: From January 2007 to December 2009, 95 heroin overdose cases occurred. Samples of blood, urine and bile were solid phase extracted (SPE) and analyzed by gas chromatography mass spectrometry (GC/MS) after derivatization. Quantitation of morphine, codeine and 6-monoacetylmorphine (6-MAM) was performed. Immunohistochemical staining was used to diagnose early myocarditis. Granulocytes, T lymphocytes and macrophages were identified. Results were compared to a control group of 30 subjects with no history of drug abuse and without postmortem evidence of any pre-existing lethal disease. The causes of death in the control cases included head traumas and traffic accidents. The subjects of the study group and the control group presented with no evidence or minor evidence of coronary atherosclerosis.

Results and Conclusion: Granulocytes, T lymphocytes and macrophages were present at significantly higher levels in the study group heroin overdose cases than in the control group, although myocarditis diagnosis was only possible in 25% of cases in the study group. However, 62% of study group cases showed mild to moderate inflammation. These immunohistochemical findings correlated significantly ($P < 0.05$) with the toxicology results.

Key Words: Heroin Overdose; Myocardial Damages, Immunohistochemistry

The Analysis of Gastric Contents to Discriminate Between Oral and Intravenous Administration of Methamphetamine**Francesco Paolo Busardò^{2*}**, Elisabetta Bertol¹, Francesco Mari¹, Paolo Procaccianti² and Antonina Argo²¹Division of Forensic Toxicology, University of Florence, Italy; ²Division of Legal Medicine, University of Palermo, Italy

Objectives: Toxicological data interpretation in conjunction with the autopsy findings is not always easy, especially in those cases where circumstantial data do not allow us to clarify the route of drug administration responsible for the death. For this reason we investigated the stomach contents of 10 autopsy cases to discriminate between oral and intravenous administration of methamphetamine (MA), taking into account and applying the borderline ratio value proposed by Moriya in his recent work (Moriya F. Accumulation of intravenously administered methamphetamine in stomach contents. *Forensic Toxicol* (2010) 28:43–46).

Materials and methods: We performed 10 autopsies in which it was possible to consider the use of intravenous drugs (MA) through a careful examination of the scene of discovery and the presence of acupuncture marks. Intervals between the last MA administration and death were estimated between 30 min. and 5 hours. A portion of the stomach contents was sampled after the whole contents were collected in a bowl and carefully mixed. Blood samples were taken from the femoral vein or the heart and a qualitative and quantitative analysis for MA was performed by gas chromatography / mass spectrometry (GC / MS).

Results: The pH values of the stomach contents (determined in 10 cases) ranged from 2,9 to 4,8 and stomach contents were 31 – 480 g. MA levels in the stomach contents were 0,461–33,6 µg/g while in blood MA levels were 0,334 – 11,8 µg/ml. The ratios of MA levels in the stomach contents to those in whole blood ranged from 2.4 to 21. A good correlation was observed in 9/10 cases between MA levels in the stomach contents and those in blood samples. The mean and standard deviation of these ratios was $x = 9,7 \pm 10,4$. These values, compared with the ratio value of 36 proposed by Moriya, confirmed an intravenous administration of MA in 9 of the 10 cases, while in 1 case it wasn't possible because a rapid death occurred (30 min).

Conclusion: In all cases, the stomach contents showed much higher MA levels than the blood samples, indicating significant postmortem redistribution of MA into the stomach. Our study confirms that stomach contents can be a valid sample for detecting intravenously administered MA because of its high levels. Furthermore, the stomach-to-blood MA ratio proposed by Moriya can be used as a criterion for discriminating oral or intravenous MA administration, making these findings useful in the practice of forensic toxicology.

Key Words: Oral/Intravenous Methamphetamine; Stomach Contents; GC/MS

Comparison of Ketamine and Norketamine Levels in Bone Marrow following Acute and Chronic Ketamine Exposure

Caroline C. Betit* and James H. Watterson

Departments of Forensic Science and Chemistry & Biochemistry, Laurentian University, Sudbury, Ontario, Canada

Objectives: Analysis of ketamine (KET) and norketamine (NKET) in bone marrow of chronically (CHR, n=8) and acutely (ACU, n=8) dosed rats is described. The purpose of this work was to determine if chronic KET exposure would result in detectable KET or NKET after a significant post-exposure delay.

Materials and Methods: ACU rats were dosed with 75 mg/kg KET (i.p.) and euthanized by CO₂ asphyxiation 15 min after administration. CHR rats were dosed once per day with 75mg/kg KET (i.p.) on 9 consecutive days, and were euthanized on the 10th day by CO₂ asphyxiation, roughly 24 hours after the last dose. Tibiae and femora were removed and bone marrow was removed, weighed and reconstituted in phosphate buffer (PB6: 0.1 M, pH6, 3 mL). Deuterated ketamine (D4KET – 200 ng/mL) was used as an internal standard, and samples were acidified with glacial acetic acid (100 µL) before undergoing a lipid/protein precipitation step with 1:1 acetonitrile:methanol and solid phase extraction (SPE). GC/MS (SIM) analysis of extracts used m/z 184, 180 and 166 as the primary ions for analysis of D4KET, KET and NKET, respectively. The detection limit of the KET and NKET was approximately 5 ng/mL.

Results: In CHR tissues, neither KET nor NKET were detected in any tibial or femoral marrow samples assayed. In marrow from ACU tissues, NKET was detected in 6/8 tibial marrow samples and 6/8 femoral marrow samples examined, while KET was detected in all tissues. In ACU tissues, KET levels ranged from approximately 7-250 µg/g, while NKET levels ranged from approximately 0.7-7.6 ng/g.

Conclusion: Overall, these data suggest that ketamine did not accumulate significantly in bone marrow following chronic exposure and an extended washout period (approximately 24 hr; t_{1/2} (KET) ~ 37 min [1]). We maintain our hypothesis that an acute dose may be differentiable from a chronic dose based on relative levels of drug and metabolite.

References:

[1] M.L. Williams, D.E. Mager, H. Parenteau, et al. Effects of protein calorie malnutrition on the pharmacokinetics of ketamine in rats. *Drug Metab. Disp.* 32(8):786-793, 2004.

Key Words: Skeletal Tissue, Postmortem, Forensic Toxicology

Case Report: Clinical and Postmortem Findings in a Fatal Valproic Acid Poisoning

Rafael Lanaro*¹, José Luiz Costa^{1,2}, Fábio Bucarechi¹, Eduardo Mello De Capitani¹, Sueli Moreira de Mello¹, Marcos Fernando Santos Mello^{3,4}, Luciano de Souza Queiroz³, Rafael Linden⁵, Lilian de Lima Feltraco Lizot⁵ and Roberta Zilles Hahn⁵

¹Poison Control Center, State University of Campinas, SP, Brazil; ²Forensic Toxicology and Chemistry Laboratory, Criminalistic Institute of Sao Paulo, SP, Brazil; ³Faculty of Medical Sciences, State University of Campinas, SP, Brazil; ⁴Institute of Legal Medicine of Campinas, SP, Brazil; ⁵Feevale University, Novo Hamburgo, RS, Brazil

Introduction: Valproic acid (VPA) is a simple eight carbon, branched-chain fatty acid that has been used as an anticonvulsant and mood-stabilizing drug, primarily in the treatment of epilepsy, bipolar disorder and major depression. It is also used to treat migraine and schizophrenia. Manifestations of acute VPA poisoning are a myriad of symptoms, reflecting both enhanced therapeutic effect and impaired intermediary metabolism. Central nervous system depression is the most common finding in acute poisoning, which may progress to respiratory depression and coma.

Objective: To report clinical and postmortem findings in a fatal case of VPA acute poisoning.

Case History: A 30 year-old man was admitted to emergency service with psychomotor agitation 2 hr after an intentional ingestion of approx 200 pills of 500 mg VPA in a suicide attempt. According to his wife, the patient was a cocaine and alcohol addict who regularly used VPA, amitriptyline, haloperidol, phenobarbital, phenytoin. After 12 hr of exposure the patient presented as follows: consciousness depression (Glasgow 8), tachycardia, arterial hypertension, hypernatremia, polyuria, metabolic acidosis and acquired nephrogenic diabetes insipidus. The VPA overdose was confirmed by the measured serum concentration (immunoassay and HPLC-DAD) of 217.7 µg/mL 34 hr post-ingestion (toxic >100 µg/mL). Serum, Blood and weighted tissue samples (about 1 g) were diluted (1:10) with perchloric acid 4%(v/v) and minced in an ultraturax, followed by centrifugation. An aliquot of 250 µL of blood or tissue precipitation supernatant were extracted with 2.2 mL of hexane at acidic pH after the addition of internal standard (cyclohexenoic acid). The organic phase was transferred to a clean tube and the derivatization reagent (phenacylbromide) and catalyst (triethylamine) were added. The mixture was evaporated to dryness for 1 hour at 60 °C. Dried extracts were injected on the HPLC using a Shimpack CLC-ODS column (150 X 4.6 mm, p.d. 5 µm) eluted with a mobile phase composed of phosphate buffer pH 2.3 (50 mM) and acetonitrile (40:60, v/v) at a flow rate of 2 mL/min. Detection was performed at 246 nm. The method was linear between 2 and 300 µg/mL. All other drugs (described above) were detected at therapeutic and subtherapeutic levels, with no detectable alcohol or cocaine. Hemodialysis was performed and VPA levels decreased to 74.3 µg/mL (58 hr) down to 11.5 µg/mL (120 hr). The patient developed cerebral edema and progressed to cerebral death 174 hr post ingestion. Necropsy macroscopic results showed extensive subarachnoid hemorrhage covering the anterior aspect of the pons. On section, there were multifocal brain stem hemorrhages affecting the left cerebral peduncle, and the basis and tegmentum pontis, including a classical Duret hemorrhage. Microscopic analysis showed hemorrhages in the pontine parenchyma; foci of hemorrhage and congestion in the lungs; intense liver steatosis; and congestion of renal and spleen blood vessels. The heart was unremarkable. VPA postmortem concentrations were: heart ventricular blood 15.6 µg/mL, femoral blood 3.0 µg/mL, heart tissue 9.2 µg/g, kidney 11.1 µg/g, liver 64.8 µg/g, and lung 129.7 µg/g.

Conclusion: This work reports an acute poisoning caused by VPA, where the patient was monitored 2 hr after poisoning until death on day 6, results presented include postmortem blood and tissue analysis. To our knowledge this is the first fully reported case of VPA poisoning with clinical and postmortem findings.

Key Words: Valproic Acid, Overdose, Clinical and Postmortem Findings

Blood Alcohol Levels in Suicide by Hanging Cases in the State of Sao Paulo, Brazil

Talita Zerbini^{1,2}, Julio de Carvalho Ponce¹, Daniele Mayumi Sinagawa², Raquel Barbosa Cintra^{1,2}, Daniel Romero Muñoz², **Vilma Leyton**^{*2}

¹Institute of Legal Medicine of Sao Paulo, Sao Paulo, Brazil; ²Department of Legal Medicine of Faculty of Medicine of Sao Paulo University, Sao Paulo, Brazil.

Introduction and Objectives: Suicide is one of the main causes of violent deaths worldwide, and has become a public health issue. The leading method of suicide varies dramatically between countries. In Germany, Japan and Hungary the most common method of suicide is death by hanging, while in the United States most suicides involve the use of firearms. The most common factors associated with suicide are depression and alcoholism, responsible for 44 and 23% of deaths, respectively. According to data from the US Center for Disease Control and Prevention, 24% of suicide victims had a blood alcohol concentration (BAC) over 0.8 g/L. Since alcohol consumption is linked with an increase in the number of suicides and hanging, we present an epidemiological analysis of BACs in victims of suicide by hanging autopsied in the State of Sao Paulo, Brazil, and aim to establish a profile of those victims, as well as an association with alcohol use.

Materials and Methods: A cross-sectional retrospective study was conducted by collecting data from autopsy reports from the victims of suicidal hanging completed by coroners at the Institute of Legal Medicine of Sao Paulo between January and December 2007.

Results and Conclusion: Blood samples (n=212) were analyzed by headspace gas chromatography. Males (84.9%) committed suicide at a rate of almost six times that of females (14.1%). The age bracket with the greatest percentage of positive cases (46.6%) was for people between 18 and 44 years. A positive BAC (over 0.1 g/L) was found in 37.3% of all cases, with a mean concentration of 1.84 ± 0.9 g/L. 18.8% of the positive cases were from females compared to 40.6% from males ($p < 0.05$). The mean BAC for female victims was 2.30 ± 1.04 g/L, and for males 0.99 ± 0.97 g/L. According to the present study, positive BAC were more common for male victims, who were six times more likely to succeed in a suicidal attempt than females. (LIM-40-HCFMUSP).

Key Words: Alcohol, Suicide, Hanging

Clozapine Overdose in an Embalmed Case**Patrick S. Ng***^{1,2}, Peter J. Koin¹ and James A. Filkins¹¹Cook County Medical Examiner Office, Chicago, IL, USA; ²Department of Pathology, University of Illinois, Chicago, IL, USA

Case History: A 39 year-old female expired at a nursing home and was released to a funeral home. The embalmed body was autopsied at the Cook County Medical Examiner Office. The deceased had a medical history of chronic obstructive pulmonary disease, congestive heart failure, high blood pressure, diabetes mellitus, bipolar disorder and schizophrenia.

Materials and Methods: The autopsy showed an obese white female measuring 5 feet 2 inches in length and weighing 180 pounds. There was evidence of embalming, which included sutured incisions in the right upper chest, midline of abdomen, and in the area of the right groin as well as trocar artifacts in the heart, lungs, liver, spleen and stomach. Additionally, there was a pronounced odor of embalming fluid in the body cavities. The only gross abnormality noted was an enlarged spleen weighing 371 grams (normal expected weight: 155 grams), but embalming precluded optimal evaluation of the internal organs. Microscopically, there was mild to moderate fatty change in the liver and emphysematous changes in the lungs. Central blood obtained from autopsy was tested for ethanol, methanol, acetone and isopropanol with dual capillary columns (Restek BAC1 and BAC2) GC (Perkin Elmer XL)-headspace method. Cocaine and metabolites, opiates, barbiturates, amphetamines, methadone and fentanyl ELISA (Immunalysis kits, Tecan Columbus washer and Sunrise reader) were performed. Cyanide was determined by colorimetric method. Basic drugs including common antidepressants were detected by liquid/liquid extraction and dual capillary columns (HP5 and HP17) with GC NPD detectors (HP 6890).

Results and Conclusion: Methanol was present in central blood. Clozapine, chlorpromazine and diphenhydramine were found. Quantitation of the identified drugs was performed by GC with MS confirmation or LC/MS/MS (National Medical Services). Central blood had clozapine (CLZ), norclozapine (NCLZ), chlorpromazine (CLP) and diphenhydramine at concentrations of 4,800, 200, 560 and 340 ng/mL respectively. Liver had CLZ, NCLZ and CLP at concentrations of 39,000, 12,000 and 15,000 ng/g respectively. Brain had CLZ, NCLZ and CLP at concentrations of 10,000, 5,900 and 9,800 ng/g respectively. Vitreous has CLZ, NCLZ and CLP at concentrations of 260, 100 and 100 ng/mL respectively. The concentrations of CLZ in central blood, embalmed liver and brain are comparable to the fatal ranges in the literature. Quantitative data may have been affected by postmortem redistribution into central blood, and the embalming process itself, through potential dilution and interaction with formaldehyde and other agents in the fluid. The cause of death is combined drug intoxication (overdose) with diabetes mellitus as a significant contributing cause.

Key Words: Clozapine, Overdose, Embalmed

Stimulant Drugs in Oral Fluid in the UKPeter Akrell*¹ and Vina Spiehler²¹Concateno, Abingdon, Oxfordshire, UK; ²Spiehler & Associates, Newport Beach, California, USA

Objective: To uncover regional and source differences in our population of oral fluid immunoassay drug positive results. All assessments are based on immunoassay results only.

Methods: From December 2007 to March 2010 our laboratory tested 74,708 oral fluid specimens for abused drugs using the Cozart Oral Swab collection device and Cozart SpinLab homogenous enzyme immunoassays for cocaine/benzoylecgonine and amphetamine, and Cozart ELISA microtiter plate immunoassay for anhydroecgonine methyl ester (AEME), a proposed marker of smoked “crack” cocaine. These saliva samples came from probation services (42,418), treatment (24,482) and mental health (4022) clinics in cities in southwest, northwest and northern eastern parts of England, UK. Test requests for stimulant drugs and positivity rates by drug, test population and region are presented. Tested populations are identified by region and type of service and are drug treatment sites in Southwest United Kingdom including Plymouth, rural Devon, and a Mental Health provider in the Thames Valley; and probation sites in Southwest United Kingdom including sites in Portsmouth, Rural Devon and Cornwall, Bristol and the Thames Valley. Also included for comparison were specimens from probation sites in the North of England in Humberside and West Yorkshire.

Results:

Table 1 Summary of tests requested and positivity rates by population type

		Treatment	Probation	Mental Health
	N	24,482	46,205	4,022
Cocaine	N (% total)	14,643 (60%)	34,157 (74%)	2,899 (72%)
	% screen positive	6.7%	24.2%	0.7%
Cocaine & AEME	N (% total)	2449 (10%)	9,242 (20%)	952 (24%)
	% screen positive for cocaine only	8.0%	14.3%	1.4%
	% screen positive for both	4.6%	8.5%	0.1%
Amphetamine	N (% total)	14324 (59%)	4,228 (9%)	2,716 (68%)
	% screen positive	7.8%	20.0%	0.5%

Table 2 Summary of tests requested and positivity rates by region for probation sites

		South Western UK sites	Northern UK Sites
	N	28,268	17,936
Cocaine	N (% total)	24,294 (86%)	9,863 (55%)
	% screen positive	22.8%	27.8%
Cocaine & AEME	N (% total)	8,891 (31%)	351 (2%)
	% screen positive for cocaine only	14.9%	20%
	% screen positive for both	8.3%	12%
Amphetamine	N (% total)	3,318 (12%)	910 (5%)
	% screen positive	12%	51%

Conclusions: The prevalence of stimulant abuse by oral fluid testing from probation and treatment donors in these regions ranged from five to fifty percent, with significant population and regional variations by drug and drug class. Cocaine abuse is more prevalent than amphetamine abuse. Smoked crack cocaine is about half the prevalence of cocaine hydrochloride, based on the AEME results. Drugs of abuse are more prevalent in probation than treatment specimens.

Key Words: Stimulants, Oral Fluid, Prevalence

Methadone Incidence in Medical Examiner's Cases in the City and County of San Francisco

Glenda M. Easterling*¹, Justin Volk¹, Jonas E. Knight¹, Patil Armenian², Eric A. Ingle¹, Chinyere M. Williams¹, Pavlos Karamanidis¹, Cecilia O. Medina¹, Ann M. Gordon¹ and Nikolas P. Lemos^{1,3}

¹Office of the Chief Medical Examiner, 850 Bryant Street, San Francisco, CA, USA; ²California Poison Control System, San Francisco Division, The University of California, San Francisco, CA, USA; ³Department of Laboratory Medicine, School of Medicine, The University of California, San Francisco, CA 94143, USA

Objectives: To present the incidence of methadone in postmortem specimens over 1 year in the City and County of San Francisco, with 815,000 residents and a greater metropolitan area of 7.15 million.

Methods: An enzyme-linked immunosorbent assay (ELISA) by Venture Labs, Inc. (Redwood City, CA) was employed to screen methadone in central/cardiac blood and urine with 20 and 300 ng/mL cutoffs, respectively. Confirmation and quantitation were performed by gas chromatography–mass spectrometry in peripheral blood or a new aliquot of urine with a limit of quantitation of 0.1 mg/L and tripeleonnamine as internal standard. The m/z ions monitored for tripeleonnamine and methadone were 91, 58, 197 and 72, 115, 294, respectively. The Division's database was interrogated for postmortem cases with methadone in blood from 7/1/2009 - 6/30/2010. Case files were manually reviewed and methadone cases tabulated.

Results: During the 12-month period, the Office of the Chief Medical Examiner assumed jurisdiction over 1,262 cases. Methadone was reported in 6.7% (n=85) of postmortem toxicology reports, giving an incidence of 10.4 per 100,000 population. 71% were males and 72% white. Subjects ranged in age from 19 to 86 years (mean and median: 48 years). Mean and median methadone blood concentrations were 0.61 and 0.44 mg/L, respectively (range: <0.10 to 2.48 mg/L). 64 of 85 cases (75%) were mannered accidental deaths with blood methadone from <0.10 to 2.48 mg/L (mean: 0.64 mg/L; median: 0.45 mg/L). 11 cases (13%) were natural deaths with blood methadone from 0.11 to 1.05 mg/L (mean: 0.26; median: 0.15 mg/L). 3 of 85 cases (4%) were suicides with blood methadone of 0.3, 0.52 and 1.1 mg/L (mean: 0.64 mg/L). 5 (6%) were homicides and in these cases blood methadone ranged from 0.23 to 1.67 mg/L (mean: 0.75 mg/L; median: 0.49 mg/L). Methadone was also reported in 2 cases where manner was undetermined with blood concentrations of 0.31 and 1.6 mg/L. Methadone was the only drug found in 9 cases (11%).

Discussion and Conclusions: Our study shows methadone incidence in postmortem toxicology investigations in San Francisco to be 10.4 per 100,000. The incidence is increasing compared to 1997-1998 (5.0 per 100,000) and 2002 (4.4 per 100,000). Polypharmacy also appears to be the norm, with methadone in combination with one or more psychoactive drugs in almost 90% of cases. Cocaine, benzodiazepines, 6-monoacetylmorphine, morphine, codeine, and ethanol were the most frequently encountered substances among our methadone positive cases. No clear relation could be established between peripheral blood methadone concentration and manner of death, as mean and median concentrations in accidents, homicides and suicides were indistinguishable. Peripheral blood methadone concentrations in natural deaths; however, had significantly lower blood methadone concentrations. Our findings strongly support that interpretation of methadone positive deaths should involve much more than just a review of postmortem blood concentrations, such as the decedent's medical history, methadone dosing and a thorough scene investigation.

Key Words: Methadone, Postmortem Peripheral Blood Concentrations, San Francisco

Controlled Substances and Quotas. The Impact of Scheduling Actions on Controlled Substances and the List I Chemicals Ephedrine, Pseudoephedrine and Phenylpropanolamine

Minh T. Dang*

Office of Diversion Control, US Drug Enforcement Administration (DEA), Washington, D.C., USA

The United States Controlled Substance Act (CSA) of 1970 and the Combat Methamphetamine Epidemic Act (CMEA) implemented in 2008 mandated that the DEA establish on an annual basis the production and import limits for the United States for Schedule I and II controlled substances and for the List I chemicals ephedrine, pseudoephedrine and phenylpropanolamine (PPA). Additionally, these Acts require DEA to establish individual import, manufacturing and procurement quotas to DEA registered importers and manufacturers of these substances.

We will provide an overview of the process to schedule a controlled substance and provide information on recent scheduling actions. Additionally we will also discuss the effects of these scheduling actions as they relate to quotas (pursuant to 21 CFR 1315 and 21 CFR 1303) and the ability for industry to manufacture, procure or import controlled substances and newly controlled substances in the United States. Those affected by quotas include suppliers of toxicological standards, manufacturers of drug test kits, manufacturers of exempt chemical preparations, manufacturers of immunoassay kits, suppliers of drug standards, pharmaceutical manufacturers, chemical manufacturers, and researchers who handle these controlled substances.

We will also discuss the CMEA and DEA's implementation of quotas in 2008 for the List I chemicals ephedrine, pseudoephedrine and PPA. As a result of the CMEA in 2008, DEA reduced the amount of ephedrine, pseudoephedrine and PPA manufactured and/or imported into the United States, known as The Assessment of Annual Needs (AAN) for ephedrine by >64 %, pseudoephedrine by >45 % and phenylpropanolamine by 74 %. The chart below summarizes the effects of quotas on the List I chemicals ephedrine, pseudoephedrine and PPA since its implementation in 2008.

The United States of America Assessment of Annual Needs (AAN) (Kilograms)

	2008	2009	2010	2011
Ephedrine (for sale)	11,500	3,400	3,900	4,200
Pseudoephedrine	511,100	390,000	404,000	280,000
PPA (for sale)	5,545	4,900	7,400	5,300
PPA (for conversion)	85,470	62,000	17,800	21,800
Ephedrine (for conversion)	128,760	120,000	75,000	18,600

Key Words: Annual Assessment of Needs, DEA Scheduling, Quotas

Detection of Drugs of Abuse in Urine – Do Standard Test Panels Cover the Actual Substances?**Roar Dyrkorn***¹, Arne Reimers^{1,2}, Ludvig Johannessen¹, Olav Spigset^{1,3}

¹Department of Clinical Pharmacology, St. Olavs University Hospital, 7006 Trondheim, Norway; ²Department of Neuroscience, Faculty of Medicine, Norwegian University of Science and Technology, 7489 Trondheim, Norway; ³Department of Laboratory Medicine, Children's and Women's Health, Norwegian University of Science and Technology, 7489 Trondheim, Norway.

Introduction: In Norway, hundreds of thousands of urine samples are analyzed every year to detect intake of drugs of abuse. Our own laboratory analyzes about 60,000 such urine specimens annually. We wished to find out if our standard panel of analyses is sufficient to detect most of the substances of abuse in Norway. This standard panel includes amphetamines, MDMA (ecstasy), cocaine, five benzodiazepines, opioids, cannabinoids, carisoprodol/meprobamate, phencyclidine (PCP, "angeldust"), and ethanol. Our laboratory also offers an extended drug screen consisting of the standard panel plus dextropropoxyphene, fentanyl, ketamine, methylphenidate, pethidine, tramadol, zolpidem.

Materials and Methods: All routine urine specimens sent to our laboratory on an arbitrarily chosen weekday during five consecutive weeks in summer 2009 were anonymised and analyzed by our extended screen plus fenazepam, lorazepam and pregabalin. The selection of these additional drugs was based on information from the police on actual seizures in Norway. In addition, four other laboratories, each from another region in Norway, sent us 250 anonymous specimens each to be analyzed for the same ten substances in order to see if the pattern of abuse exhibits regional differences. All analyses were performed by LC-MS methods developed by our laboratory. The lower limits of quantification were at or below SAMHSA recommendations. Specimens were reported as dilute when the creatinine concentration was less than 2 mmol/L.

Results: Of the 858 samples sent directly to our laboratory, 268 (31%) were positive for one or more substances. The highest number of not-prescribed substances in one sample was six (cannabinoids, morphine, amphetamine/methamphetamine, oxazepam, nitrazepam and flunitrazepam, in addition to legally prescribed buprenorphine). A total of 1,854 urine specimens were analyzed by the extended drug screen. In 123 samples (6.6%), substances not covered by the standard test panel were detected. Pregabalin was detected in 83 samples (4.5%), methylphenidate in 33 (1.8%), tramadol in four (0.2%) and lorazepam in one (0.05 %). The proportion of samples containing substances of abuse not covered by our standard test panel was 20.8% in Bergen, 9.8% in Kristiansand, 8.0% in Tromsø, 2.8% in Oslo and 2.3% in Trondheim.

Conclusions: Most drugs of abuse are detected with the standard test panel offered by the participating laboratories. However, there are considerable regional differences in the pattern of drug abuse. Therefore, laboratories performing drug screening tests should consider carrying out quality studies like this on a regular basis to see if the composition of their test panels needs adjustment.

Keywords: Substances of Abuse, Laboratory Analyses, Quality Management

Simple and Highly Efficient Drugs of Abuse Testing Methods by SPE and LC/MS/MS**Irina Dioumaeva***¹, William Hudson¹ and John Hughes²¹Agilent Technologies, Lake Forest, CA, USA; ²Agilent Technologies, Pleasanton, CA, USA

Introduction and Objectives: New Substance Abuse and Mental Health Services Administration (SAMHSA) guidelines effective October 2010 allow liquid chromatography tandem mass spectrometry (LC/MS/MS) methods to be used for confirmation of initial drug tests by government-certified (National Laboratory Certification Program [NLCP]) workplace drug testing labs. SAMHSA requires separate screening methods for the following categories of drugs and metabolites in urine: 1) 6-acetylmorphine; 2) phencyclidine; 3) benzoylecgonine; 4) a group of 5 amphetamines; 5) morphine and codeine, and 6) 11-nor-9-carboxy- Δ^9 -tetrahydrocannabinol. We present simplified LC/MS/MS confirmation methods, including sample preparation, for all categories of SAMHSA-required drugs and metabolites using the latest instruments and separation tools from Agilent Technologies (Santa Clara, CA), including Bond Elute Plexa PCX mixed mode polymeric SPE cartridges.

Materials and Methods: Without elaborate sample pretreatment, solid phase extraction on Plexa PCX provides high extraction efficiency (absolute recoveries around 90%) and reduced ion suppression (losses due to matrix effect <10%) due to a combination of a strong cation exchange functionality, an amide-free polymer surface and a hydrophilic pore gradient. LC separations for all drug categories and potential interferences employ low volume columns providing shorter retention times and better peak resolution than most existing methods. With maximum pressure below 400 bars, these methods do not require high pressure UPLC systems.

Results and Conclusion: As required by the SAMHSA guidelines and NLCP, our MS/MS methods use qualifier ions and are linear across a wide dynamic range. The methods demonstrate signal to noise ratios > 100 for the lowest required concentrations of analytes.

Key Words: Drugs of Abuse, SAMHSA, LC/MS/MS

Utilization of GC-TOFMS and Automated Sample Derivatization for Forensic Urine Drug Testing by SAMHSA Guidelines

John Heim* and Joe Binkley

Life Science and Chemical Analysis Centre - LECO Corporation, St. Joseph, MI, USA

Introduction and Objectives: Gas chromatography time-of-flight mass spectrometry (GC-TOFMS) with auto-derivatization was utilized for forensic urine drug testing using SAMHSA guidelines. The benefits of GC-TOFMS for drug confirmation in urine include the ability to acquire full range non-skewed mass spectra at fast acquisition rates capable of targeted and nontargeted analysis in a single injection. TOFMS provides optimum sensitivity and the data density necessary to allow processing by deconvolution software algorithms, which can successfully identify targeted and untargeted drugs with full range mass spectra, even in complex samples that contain severely overlapping peaks.

Materials and Methods: Experimental methods were conducted on two drug classes using benzoylecgonine and 6-monoacetylmorphine spiked into 5 mL aliquots of urine. Benzoylecgonine was spiked into 5mL urine aliquots at 100, 250, and 500 ng/mL along with 6-monoacetylmorphine spiked at 10, 50, and 100 ng/mL. The spiked 5 mL urine samples were prepared with solid phase extraction (SPE) and derivatization by established methods. Extraction was performed using UCT CleanScreen SPE cartridges and a Supelco SPE vacuum manifold with a methylene chloride:isopropanol:ammonium hydroxide mixture (78:20:2). Automated sample derivatization using N,O-bis(trimethylsilyl)trifluoroacetamide plus 1% trimethylchlorosilane (BSTFA + 1% TMCS) was conducted using a dual rail multipurpose autosampler prior to GC-TOFMS analysis. The auto-derivatization was developed in a Gerstel Maestro method to add 50 μ L ethyl acetate and 50 μ L BSTFA + 1% TMCS to the dried down extract vial. The vial was then moved to the Gerstel agitator/heater for derivatization and intermittent agitation. The derivatization temperature was set to 70°C for 20 min. The sample was then moved back to the sample tray and a 1 μ L injection for GC-TOFMS analysis was made immediately following derivatization. The TOFMS method used a mass range of 45 – 750 amu acquired at 10 spectra per sec. The sample turnaround time for the automated method was 39 min.

Results: Results show drug identification using both ion-ratios with three ions, and full range mass spectral library search, as well as retention time windows. Ion ratios were used to further confirm full mass range NIST library searchable spectra. The match similarity criterion for the library search was set to be greater than or equal to 70% match. Ion ratios were used to confirm identification by using the ratio of two ion intensities with a third ion set as the base peak. The ion ratio tolerance criteria was set at 20%. The qualifier ions used for benzoylecgonine were 240, 361, and 82 m/z. The qualifier ions used for 6-monoacetylmorphine were 399, 341, and 73 m/z. Quantitative calibration curves that meet mandatory SAMHSA cutoff concentration limits were developed. The calibration range used for benzoylecgonine was from 100 to 500 ng/mL and for 6-monoacetylmorphine from 10 to 100 ng/mL. Consistent results were obtained for both drug metabolites at the SAMHSA cut-off concentrations. The data illustrate low level identification and quantification of drugs in urine using GC-TOFMS.

Conclusion: This research investigation by GC-TOFMS with automated derivatization showed promise as a valuable tool for urine drug screening. Low level drug metabolite detection was demonstrated below the SAMHSA minimum cutoff concentrations. Calibration linearity >99% was achieved. An automated derivatization and sample analysis was verified that improves sample turn around time. A customized forensic report showed quantification, full range mass spectral library searchable identification, and analyte confirmation using qualifier ion ratios mandated by SAMHSA. A GC-TOFMS analysis solution was demonstrated using SAMHSA mandated guidelines.

Key Words: GC-TOFMS, Auto-Derivatization, Qualifier Ions

Cannabis and Cocaine Detection in Workplace Drug Testing in Italy

Paolo Emilio Santoro^{1*}, Nicola Magnavita¹, Isabella De Nardis¹, Pietrangelo Fronterre¹, Marialinda Felli², Simona Martello², Marcello Chiarotti², Antonio Bergamaschi¹

¹Catholic University of the Sacred Heart, Institute of Occupational Medicine, Rome, Italy; ²Catholic University of the Sacred Heart, Forensic Toxicology Analytical Unit, Rome, Italy

Objectives: To evaluate the prevalence of drug users in a sample of Italian haulers. The Italian Decree on Health and Safety at Work (81/08) prescribes mandatory drug tests for jobs which pose safety hazards to others. Workplace drug testing (WDT) is performed in accordance with the “Provision of the Government-Regions Conference, September 18th, 2008”.

Materials and Methods: 660 urine samples were collected from September 2009 to March 2011 in 40 industrial and service companies located in different Northern, Central and Southern Italian Regions. Observed sample collection was carried out at the workplace, according to standardized procedures, by qualified laboratory personnel from the Institute of Occupational Medicine of the Catholic University of the Sacred Heart (UCSC) of Rome. The workers to be tested were informed the day before, according to national procedures. The samples were checked for adulteration, coded and sent immediately to the laboratory of the UCSC Forensic Toxicology Analytical Unit. The screening test was performed by a semi-quantitative assay using Siemens Viva E Drug Analyzer EMIT (Enzyme Multiplied Immunoassay Technique); positive samples were subsequently tested with liquid chromatography tandem mass spectrometry (LC-MS/MS). The cut-off concentrations applied for the screening test were 50 ng/mL for cannabis and 300 ng/mL for cocaine. The cut-off values for the confirmatory test were 15 ng/mL for cannabis and 100 ng/mL for cocaine.

Results: Out of 660 urine samples analyzed for cannabis, opiates, amphetamines, methamphetamines, cocaine, methadone and MDMA, 16 samples (2.4%) tested positive for cannabis and/or cocaine with the screening test but only 4 of them (0.6%) were confirmed with the LC-MS/MS analysis. Cannabis was detected in 1 specimen, cocaine in 2 specimens, 1 sample contained both cocaine and cannabis. No sample tested positive for other illicit drugs. All the samples resulted to be valid, neither adulteration nor dilution were detected.

Conclusions: The prevalence of positive tests in the observed population was lower than expected, if we consider that most of drug users are work-aged subjects with a permanent job, and the national prevalence of drug users, according to the National Drug Report 2010, is 5.2% for cannabis and 0.9% for cocaine. The low percentage of subjects testing positive cannot be attributed to analytical methods, which are highly specific and sensitive, and might be explained by the choice of urine as biological specimen. The use of urine as biological specimen to perform WDT can lead to an underestimation of the prevalence of drug users at workplace because of the narrow urinary detection window (although cannabis remains detectable in urine for a longer time than other drugs) and the availability of several methods to subvert the testing procedures (substitution, dilution, adulteration). The use of hair as a biological specimen for WDT could provide more reliable data in workplace controls, even so far the Italian law prescribes its use only in Drug Rehabilitation Centers, as a “second level test”, or for forensic medicine aims.

Key Words: Workplace Urine Drug Testing, Hazardous Jobs, Italian Law, Cocaine, Cannabis

Analysis of 2008-2009 Urine Drug Testing Results from a Medical Review Officer Data Source

Michael R. Baylor*¹, John M. Mitchell¹, James L. Ferguson², Andrew von Brand¹, and J. Michael Walsh³, ¹Center for Forensic Sciences, RTI International, RTP, NC, USA; ²FirstLab, Chalfont, PA, USA; ³The Walsh Group, Bethesda, MD, USA

Introduction: Drug testing indices which are based only on laboratory confirmed positive results may not accurately represent illicit drug use rates since they include blind quality control samples and results later reversed after Medical Review Officer (MRO) determination of valid medical explanations for the test results.

Objectives: At the request of Substance Abuse and Mental Health Services Administration, Department of Health and Human Services, the relationship between laboratory reported drug test results and MRO verified results reported to employers in federally regulated (FR) and non-regulated (NR) workplaces and the results for NR synthetic opioid positive drug tests were evaluated.

Methods: Records for 1.74M FR and NR urine specimens collected during 2008-2009 from employees in more than 6,000 companies were obtained from a large MRO data source. The database includes donor demographics, employer information, collection site information, laboratory results, and MRO determinations but does not include agency or employer blind quality control samples. Virtually all drug test results (99.9%) were from SAMHSA-certified laboratories. All records were handled in compliance with the DHHS Human Subject protection criteria.

Results: Confirmed positive rates ranged from 1.21 % (2008 FR specimens) to 4.23 % (2009 NR specimens), and MRO reversal rates ranged from 19.98 % (2008 FR specimens) to 43.16 % (2009 NR specimens). About 75% of the NR specimens were tested for synthetic opioids which account for almost half of all NR opioid confirmed positive results. MRO review determined that a majority of FR and NR opioid positive drug tests were due to legitimate prescription drug use.

Specimens Tested	Federally Regulated ^a						Non-Regulated ^b					
	% Laboratory Confirmed +		% MRO Verified +		% MRO Reversed		% Laboratory Confirmed +		% MRO Verified +		% MRO Reversed	
Year	2008	2009	2008	2009	2008	2009	2008	2009	2008	2009	2008	2009
Total All Drugs	1.21	1.02	79.86	75.68	19.98	24.25	4.04	4.23	63.45	56.83	36.49	43.16
Amphetamines	0.19	0.20	35.03	24.36	64.97	75.64	0.43	0.52	21.79	19.94	78.18	80.06
Cocaine	0.24	0.17	100	100	0	0	0.34	0.24	99.96	99.86	0.04	0.14
Marijuana	0.66	0.55	99.03	99.74	0.78	0.26	1.88	1.76	99.70	99.69	0.27	0.31
Phencyclidine	0.003	0.002	100	100	0	0	0.01	0.01	100	100	0	0
Opioids^c	0.15	0.12	23.31	18.86	78.86	80.57	0.73	0.93	21.26	19.61	78.64	80.39
Hydrocodone							0.03	0.07	12.74	11.54	87.22	88.46
Hydromorphone							0.03	0.04	13.42	11.25	86.51	88.75
Oxycodone							0.13	0.12	28.16	25.80	71.52	74.20
Oxymorphone							0.10	0.10	33.42	29.76	66.33	70.24
Barbiturates							0.38	0.36	16.78	16.45	83.02	83.54
Benzodiazepines							0.76	0.75	23.73	23.15	76.20	76.82

^a Number of FR specimens = 156,907 in 2008 and 141,063 in 2009 (Down 50% from 2006-2007)

^b Number of NR specimens 826,600 in 2008 and 618,552 in 2009.

^c FR opioid data includes codeine, morphine and 6-acetylmorphine; NR opioid data also includes the synthetic opioids hydrocodone, hydromorphone, oxycodone, and oxymorphone.

Conclusions: Comparing year 2008 to 2009 for all drug classes combined, MRO verified positive rates decreased; hence, MRO reversals increased. In FR testing, there was an increase in the reversal rates for natural opioids (+1.7%) and amphetamines (+10.7%). In the NR data, increased MRO reversal rates were found in the amphetamine, natural and synthetic opioid, barbiturate, and benzodiazepine drug classes. In NR Testing, 43% of all laboratory positives were reversed in the MRO process which makes laboratory confirmed data possibly misleading.

Key Words: Workplace Drug Testing, Database Analyses, Medical Review Officer

Analysis of Selected Drugs of Abuse and their Pyrolytic Products by LC/MS/MS

Lucy S. Oldfield* and Suzanne C. Bell

West Virginia University, Morgantown, WV, U.S.A

Introduction and Objectives: Recent work involving pyrolysis of common drugs of abuse has shown evidence of distinct products. Presence of these pyrolytic products in biological matrices may be an indication of smoking abuse; however, common assays do not include pyrolytic products or their metabolites. Cocaine and fentanyl, two forensically important drugs, produce distinctive pyrolytic products, anhydroecgonine (AECG) and propionanilide respectively. AECG has been previously reported as unusable as a biomarker due to its production from the hydrolysis of anhydroecgonine methyl ester (AEME) in GC injector ports and upon prolonged storage of plasma or high pH conditions. However, with careful storage and use of ambient temperature analysis techniques, this analyte could be a useful biomarker for smoked cocaine. Propionanilide has been seen in recent work carried out in this laboratory as a stable pyrolytic product and shows potential for use as a biomarker for smoked fentanyl. Under pyrolytic conditions the two reported metabolites of fentanyl, norfentanyl and despropionylfentanyl, are also observed with propionanilide being the major product. While it would be possible to develop a gas chromatography mass spectrometry assay for detection of these biomarkers, liquid chromatography tandem mass spectrometry (LC/MS/MS) is a more attractive technique offering greater selectivity and sensitivity. The current study involves the validation of a LC/MS/MS method for analysis of cocaine, fentanyl and their major pyrolytic products and relevant metabolites in urine

Materials and Methods: Urine samples were prepared by adding standard and internal standard solutions to 1 mL specimens. Urine was diluted 1:1 with water followed by cold acetonitrile, centrifuged and the supernatant evaporated under N₂. Samples were reconstituted in buffer. Separation was performed by gradient reverse-phase liquid chromatography using a standard C₁₈ column (3 μm particle size, 50 x 2.1 mm). A Qtrap was operated in positive mode with electrospray ionization (ESI). A multiple reaction monitoring (MRM) survey scan and enhanced product ion (EPI) dependent scan with information-dependent acquisition (IDA) were performed with a total run time of 8 minutes. Dynamic exclusion of triggered MRM transitions was used to detect coeluting compounds. A minimum of two characteristic MRM transitions for each compound (ion ratio ± 15%) were selected with quantitative transitions chosen as: cocaine 304/182 *m/z*, norcocaine 290/136 *m/z*, ecgonine 186/168 *m/z*, AEME 182/118 *m/z*, AECG 168/122 *m/z*, fentanyl 337/188 *m/z*, despropionylfentanyl 281/188 *m/z*, norfentanyl 233/150 *m/z*, propionanilide 150/106 *m/z* and norfentanyl-d₅ 238/84 *m/z* (IS).

Results: The assay was linear from 0.1 or 1-500 ng/mL (compound dependent), limit of detection was 0.05 – 0.5 ng/mL and intra-and inter-day imprecision were less than 15%.

Conclusion: This study demonstrates the potential use of AECG and propionanilide as biomarkers for smoked cocaine and fentanyl respectively. A sensitive LC/MS/MS method for the identification of pyrolytic products and metabolites of two commonly abused substances has been validated. This method could be adapted for analysis of other pyrolytic products.

Key Words: Pyrolysis, Biomarkers, LC/MS/MS

Swiss Guidelines 2011 for Drugs of Abuse Testing

Rudolf Brenneisen^{1,2}, Ingeborg Bertschi^{1,3}, Thomas Briellmann^{1,4}, Katharina Rentsch^{1,5}, André Deom^{1,6}, Hans Küffer^{1,7}, André Scholer^{1,8}, **Pierre-Alain Binz***^{1,9,10}

¹Swiss Guidelines Committee for Drugs of Abuse Testing (SCDAT) committee; ²Department of Clinical Research, University of Bern, Bern, Switzerland; ³Abbott AG, Baar, Switzerland; ⁴Institute for Legal Medicine, Basel, Switzerland; ⁵Institute for Clinical Chemistry, University Hospital, Zurich, Switzerland; ⁶Veyrier, Switzerland; ⁷Grimisuat, Switzerland; ⁸Basel, Switzerland; ⁹Swiss Institute of Bioinformatics, Geneva, Switzerland; ¹⁰Geneva Bioinformatics SA, Geneva, Switzerland

Introduction: The Drugs of Abuse Testing (DAT) Laboratory Guidelines are a revision of the Swiss Arbeitsgruppe Suchstoffanalytik (AGSA) guidelines published in 1996. They were revised and actualised by a committee representing members of institutions such as the Swiss Association of Pharmacists, the Swiss Society for Clinical Chemistry, the Swiss Society of Legal Medicine, the Swiss Association of Diagnostics Manufacturers, and the Swiss Society for Directors of Clinical Laboratories and the University of Bern.

Materials and Methods: The DAT guidelines are intended as recommendations and have no legally binding intention. The objectives of SCDAT are to periodically update and harmonize DAT in Switzerland in accordance with international guidelines.

The guidelines contain an evaluation of current methods applied to drug analysis in urine and blood (on-site tests, instrumental immunoassays, chromatography, mass spectrometry), recommendations for cut-off values, comments on quality assurance, documentation on specimens, analyses and results, interpretation and legal aspects. The guidelines cover four main application domains, i.e. therapeutics (medical), forensics, and workplace testing. Short reviews of pharmacokinetics summaries for a selection of important drugs of abuse complete the document.

Sample conservation data, cut-off values for immunoassays, and proposed methods for quantitative analysis are available for a number of substances and substance classes such as Buprenorphine, THC/THC-COOH, Benzoyllecgonine/Cocaine, LSD, Methadone, EDDP, Methaqualone, Opiates, Amphetamines, Barbiturates, Benzodiazepines and Tricyclic Antidepressants.

Conclusion: This revision includes updated values, new methods and new external quality controls and also is adapted to current legal standards. The DAT guidelines are currently available in German and will soon be published in English and French on www.scdat.ch.

Key Words: Drug of Abuse Testing, Guidelines

UPLC[®]-MS/MS Method for SAMHSA Compliant Workplace Urine Drug Testing

Rob Lee* and Michelle Wood.

Waters Corporation, MS Technologies Centre, Manchester, UK

Objectives: Recent changes to the Mandatory Guidelines for Federal Workplace Drug Testing Programs now allow the use of LC-MS/MS for urine drug confirmations. The aim of this work is to develop both sample preparation and UPLC-MS/MS methods for the quantitation of SAMHSA workplace testing analytes.

Methods: Samples were prepared by solid phase extraction which involved adding deuterated internal standards and basic buffer prior to clean up and elution from an Oasis[®] HLB cartridge (Waters Corporation, Milford, MA). The extracted analytes were separated on a Waters ACQUITY UPLC system using an ACQUITY UPLC HSS T3 C18 column (100 x 2.1mm, 1.8 μ m) with 2mM ammonium formate containing 0.05% formic acid and methanol as the mobile phases and a chromatographic run-time of 10.25 minutes. The analytes were detected using a XEVO TQ-MS with electrospray ionisation in positive ionisation mode. Authentic urine samples were analyzed utilizing this method and the results were compared to those obtained using GC-MS.

Results: The developed method was assessed for accuracy, precision and linearity, and both intra-day inter-day variability and over a 5 day period. Over the 5 day study, the r^2 values for linearity in the concentration range from zero to greater than or equal to 125% of the cut-off values were all above 0.995. The %RSD for calibrator and QC replicates over the 5 day period at each concentration were <15% and the concentrations of analyte found were within 20% of target. Recovery and matrix effects were investigated in 6 separate urine samples at 2 concentrations. Recoveries ranged from 61% (carboxy-THC) to 95% (Benzoylcegonine), and matrix effects ranged from -26% (Codeine) to +8% (Codeine glucuronide). LOD, LOQ and ULOL for each analyte were determined and carryover was shown to be less than 50% of the LOD for each analyte. Each analyte was shown to be free from common interferences at 40% of the cut-off level. More than 125 authentic samples were analyzed and those that assayed as positive gave excellent correlation, with r^2 values of above 0.99 (minimum n = 8 per positive analyte), when compared to the results from the GC-MS method.

Conclusions: This work presents a fast, sensitive and reliable method for analyzing the SAMHSA panel of analytes. This method allows for the 5 drug classes to be analyzed using a single procedure without hardware or mobile phase changes to levels below the 40% of the cut-off as is currently needed. The simple sample preparation method allows for the analysis of free and conjugated analytes, which eliminates the need for harsh hydrolysis conditions.

Key Words: SAMHSA, Urine, UPLC[®]-MS

Anomalous Results of Morphine and 6-Acetylmorphine in Urine Samples

Peter R. Stout, **Cynthia Lewallen***, Nichole Bynum, Tiffany Freed, Melanie Rehder-Silinski Jeri D. Roper-Miller, John M. Mitchell, and Susan Crumpton
RTI International, Research Triangle Park, NC, USA

Objective: As of October 2010, new guidelines established by the Department of Health and Human Services (HHS) concerning the analysis of 6-acetylmorphine (6-AM) became effective. A unique biomarker indicative of heroin use, 6-AM is typically present at approximately 1-3% of the concentration of total morphine after administration of heroin. In the past, 6-AM was confirmed when an initial screening for morphine yielded a result >2000 ng/mL. However, due to concerns of false negative results for heroin use and to improve laboratory processing, the new guidelines allow for initial testing for 6-AM specifically. At the request of the Office of Drug & Alcohol Policy & Compliance, Department of Transportation and with the concurrence of the Substance Abuse and Mental Health Administration, Department of Health and Human Services from November 2010 to January 2011 the National Laboratory Certification Program (NLCP) was presented with 44 urine samples from federally regulated workplace drug testing (WPDT) labs that tested positive for 6-AM and screened negative for morphine /codeine. Upon confirmatory testing by the labs, many of the samples contained morphine below the detection levels of the labs. These samples were released by the Department of Transportation and sent to RTI International for further testing by the NLCP. The goal of this research was to investigate these atypical results and to determine if other drugs or metabolites present in the samples could explain the lack of morphine present, or if the source of the 6-AM could have been something other than heroin.

Methods: The samples were analyzed by three separate LC/MS/MS techniques 1) a dilute and shoot method for 6-AM, codeine, morphine, morphine-3- β -D-glucuronide, morphine-6- β -D-glucuronide, and codeine-6- β -D-glucuronide 2) an acid hydrolysis with solid phase extraction method for total morphine and codeine and 3) a solid phase extraction without hydrolysis for 6-AM. For all methods, deuterated internal standards for the appropriate analytes were added to the samples prior to analysis. Samples analyzed for total morphine and codeine were subjected to acid hydrolysis at 120 °C prior to solid phase extraction. Extractions were performed on each sample (volume permitting) by two different analysts. All samples received at RTI were analyzed on an Agilent Technologies (Santa Clara, CA) 1200 Series liquid chromatography system coupled to a 6410 triple quadrupole mass spectrometer (QQQ), operated in positive ESI mode. The samples from both the dilute and shoot and extraction methods were also screened on an Agilent 1200 Series liquid chromatography system coupled to an Agilent 6230 time-of-flight (TOF) mass spectrometer. A set of 18 other opioid and opioid-like drug standards were analyzed by the TOF system, and this data was used to screen the urine samples for the presence of these other drugs.

Results: The presence of 6-AM was re-confirmed in all samples by both the dilute and shoot and extraction methods. Of the 44 samples received at RTI, 9 were blind QC samples expected to contain only 6-AM. Of the 35 remaining donor specimens analyzed with the “dilute and shoot” method, 30 had detectable morphine or codeine (free or conjugated) present at concentrations greater than 5 ng/mL. After hydrolysis and extraction, detectable amounts of free morphine were found in all samples as would be expected from converting the 6-AM known to be present in the samples. TOF screening results for some specimens indicated the potential presence of other opioid compounds, but appeared to be impacted by matrix effects.

Conclusions: Since all samples had 6-AM reconfirmed by an analytical method utilizing mild conditions (dilute and shoot), the observed 6-AM in the samples is not the result of an analytical artifact. The TOF screening results were more equivocal for the presence of other compounds and were not as useful. Differences in variability in 6-AM results between the dilute and shoot and the extracted samples, suggest that matrix effects may limit the utility of dilute and shoot methods for opiates and 6-AM analysis.

Key Words: 6-Acetylmorphine, Workplace Drug Testing, NLCP

Workplace Drug Testing: Outcomes After One Year of Observation

Marialinda Felli¹, Simona Martello¹, **Paolo Emilio Santoro**^{2*}, Antonio Bergamaschi², Gennaro Palma³, Maria Luigia Cerabino³, Carmela Fraietta³ and Marcello Chiarotti¹

¹Catholic University of the Sacred Heart (UCSC), Forensic Toxicology Analytical Unit, Rome, Italy; ²Catholic University of the Sacred Heart (UCSC), Institute of Occupational Medicine, Rome, Italy; ³Rete Ferroviaria Italiana (RFI), Direzione Sanità, Rome, Italy

Objectives: Application to workplace drug testing (WDT) of a validated LC-MS-MS method for confirmation of drugs of abuse in urine. The urine samples from Italian workers were collected from January to December 2010 and analyzed for cannabis, opiates, amphetamine, methamphetamine, MDA, MDMA, cocaine and methadone, as required in Italy by the "Provision of the Government-Regions Conference, September 18th, 2008".

Materials and Methods: 7522 urine samples were collected in 2010 from the RFI biochemical analysis laboratory of Rome. The samples were checked for adulteration, coded and submitted to immunologic screening tests. The screening tests used by the RFI biochemical analysis laboratory were ELISA monoclonal assays. All the samples that tested positive were immediately sent to the laboratory of the Forensic Toxicology Analytical Unit of UCSC, where the samples were subjected to the confirmatory analysis using a direct injection LC-MS-MS method. The method was validated and proved to be accurate (RSD less than 15%), precise (intra-day CV less than 10% for all the analytes) and sensitive with limits of detection (LOD) ranges from 1 ng/ml for methadone to 25 ng/ml for morphine-3-glucuronide.

Results: 59 samples (0.8%) were positive by immunologic screening tests (11 for cannabis, 9 for opiates, 1 for cocaine, 4 for methadone and 34 for amphetamine or MDMA), but only 15 of them (0.2%) were confirmed with the LC-MS-MS analysis. 9 samples were confirmed for cannabis, 4 for opiates, one was confirmed for cocaine and one for methadone. Thirty-four urine samples resulted as positive to the screening test for amphetamine or MDMA, but they were not confirmed.

Conclusions: The low percentage of subjects testing positive may not be attributed to analytical methods, which are highly specific and sensitive, and might be explained by the specific job category selected for this study. In fact most of the workers checked by RFI were professional train drivers and RFI, the owner of Italy's railway network, since 2008 has implemented a successful drug-free workplace training program for this job category. Moreover such workers, performing "hazardous" job tasks, may be refrained from using drugs of abuse because of the felt responsibility.

Key Words: Workplace Drug Testing, LC-MS-MS Analysis, Italian Law

Evaluation of the Randox Biochip Array Technology for the Screening of Drugs of Abuse in Urine

Silvia Tameni¹, Alberto Piccinotti¹, Ivan Floris¹, Gabriele Zanchetti¹ and Aldo Polettini^{2,*}

¹Synlab Italia S.r.l., Brescia, Italy; ²Department of Public Health & Community Medicine, University of Verona, Italy

Objectives: In order to evaluate the Randox Biochip Array Technology for drugs of abuse in urine (DOA I), 164 Workplace Drug Testing urine samples were screened with: (a) DOA I simultaneous multi-analyte assay including amphetamine (AMP), Δ^9 -tetrahydrocannabinol (THC), benzoylecgonine (BZG), methamphetamine (MAMP), methadone (MTD), and opiates (OPI, with morphine as target analyte) run on an Evidence Investigator (Randox, Antrim, UK) semi-automatic analyser; (b) EMIT II Plus DAT sequential assays for AMP, THC, BZG, MAMP, MDMA and analogues (XTC), MTD, OPI, and buprenorphine (BUP) run on a fully automated Dimension RXL analyser (Siemens, Deerfield, IL, USA); and (c) ONLINE DAT II sequential assays for AMP, THC, BZG, MTD, OPI, BUP run on a fully automated COBAS Integra 800 analyser (Roche, Basel, Switzerland).

Materials and Methods: All assays were performed according to manufacturer instructions. GC-MS confirmation (using a method based on deuterated internal standards, mixed-mode SPE, fast GC separation, and MS-SIM detection) was performed whenever a sample tested positive for at least one of the immunoassays. The screening cut-offs were: OPI, BZG, and MTD, 300 ng/ml; AMP, MAMP, and XTC, 500 ng/ml; THC, 50 ng/ml; BUP, 5 ng/ml for all three assays except the DOA I in which BZG and THC cut-offs were lowered to 200 and 20 ng/mL, respectively, to reduce the false negatives (FN) rate. Despite this, the calibration procedure was successfully completed and controls were within the acceptable range.

Results: OPI: 24 out of the 29 samples screened positive were confirmed by GC-MS. All three immunoassays detected all true positives (TP); 2 false positives (FP) out of 5, 0/5 and 3/5 FP were obtained with DOA I, EMIT II and ONLINE II, respectively. BZG: 46 samples screened positive and 44 of them were confirmed. All 44 TP were detected by DOA I and ONLINE II, and 43 out of 44 TP were detected by EMIT II corresponding to its sensitivity (SE) of 0.98; 1 FP was detected by DOA I and none by EMIT II and ONLINE II. THC: 51 out of the 62 samples screened positive for THC were confirmed by GC-MS; sensitivity of the three immunoassays was as follows: DOA I, 0.96; EMIT II, 0.98, and ONLINE II 0.98; the rate of FP was 3/11, 0/11 and 10/11, respectively. MTD: 14 samples screened positive and 13 were confirmed. No FN were reported by any of the immunoassays, and the only TN was reported as negative by DOA I and EMIT II and as positive (FP) by ONLINE II. AMP/MAMP/XTC: only 1 out of the 18 samples screening positive with one of these assays was confirmed as positive and found to contain both MAMP and AMP; the sample screened positive with the DOA I AMP and MAMP assays, with the AMP ONLINE II assay, and with the AMP EMIT II assay. However, the three immunoassays showed differences in the overall AMP/MAMP/XTC rate of FP: EMIT II, 7/17; DOA I, 8/17; ONLINE II: 13/17. BUP (not included in DOA I): both EMIT II and ONLINE II detected 14 positives, all confirmed by GC-MS.

Conclusions: The 3 immunoassays showed an overall comparable sensitivity, with more pronounced, although substance-dependent, differences in specificity. The multi-analyte approach of DOA I allows a rapid broad-range screening (simultaneous semi-quantitative screening of 8 drug classes + creatinine) in comparison with the other two sequential immunoassays. The need to reduce DOA I BZG and THC cut-offs, resulting in FN decrease with no relevant FP increase, remains unclear. The manual ability required during sample processing with the Investigator analyser, especially in comparison with the other fully automated analysers, might have played a role.

Key Words: Drugs of Abuse, Immunoassay, Urine

A Simplified Approach to the Extraction of Benzodiazepines from Urine Using Supported Liquid Extraction (SLE) Prior to LC-MS/MS Analysis

Rhys Jones, **Lee Williams***, Helen Lodder, Steve Jordan, Richard Calverley, Claire Desbrow and Gary Dowthwaite
Biotage GB Limited, Dyffryn Business Park, Cardiff, CF82 7TS, UK

Introduction: Benzodiazepines are psychoactive drugs that assist in the treatment of a variety of illnesses, including insomnia, anxiety, seizures, muscle spasms and alcohol withdrawal. The frequency of abuse, occurrence in post-mortem sampling, driving offences and date rape has led to the necessity for rapid and reliable methods for their analysis and quantitation. The benzodiazepines tested with this methodology were: midazolam, bromazepam, α -hydroxyalprazolam, nordiazepam, oxazepam, estazolam, alprazolam, lorazepam, triazolam, diazepam, temazepam and flunitrazepam. This poster demonstrates a rapid and reliable 96-well Supported Liquid Extraction assay for the extraction of various benzodiazepines from urine. In this case, analytes were identified after extraction by LC-MS/MS.

Methods: Supported liquid extraction was performed on blank human urine (100 μ L) spiked with various benzodiazepines at concentrations between 5-50 ng/mL. Extraction performance on both unhydrolyzed and hydrolyzed urine was investigated using a variety of pre-treatment and extraction solvent combinations. Urine hydrolysis conditions were performed in order to simulate deconjugation and real world sample pre-treatment in a forensic environment. Extraction solvents investigated were dichloromethane, methyl tert-butyl ether, dichloromethane (DCM)/propan-2-ol, butylacetate and ethyl acetate (EtOAc). The extracts were evaporated to dryness and reconstituted in 80/20 H₂O/MeOH for analysis. All samples were analysed using a Waters 2795 liquid handling system coupled to a Quattro Ultima Pt triple quadrupole mass spectrometer. Chromatography was performed using a Kinetix C18 (50 x 2.1mm x 2.6 μ) HPLC column with an isocratic mobile phase of 70/30 0.1% formic acid (aq) and acetonitrile at a flow rate of 0.3 mL/min. Positive ions were acquired using electrospray ionization operated in the MRM mode.

Results: Extraction efficiencies from unhydrolyzed urine demonstrated that a variety of pre-treatment and extraction solvent combinations resulted in recoveries greater than 70%. DCM shows the most consistent results across the pH range from 3-10. All analytes showed better results when the loading pH was at pH 6 or above as opposed to low pH loading at pH 3. Enzymatic hydrolysis using beta glucuronidase at pH 5 again demonstrated high reproducible extraction recoveries, typically greater than 75% when combined with DCM, 95/5 DCM/IPA, butylacetate and EtOAc as extraction solvents. RSDs below 10% were seen with a variety of protocols on hydrolysed and unhydrolysed urine. Optimum method performance was observed using DCM as the extraction solvent. Limits of detection were below 10 ng/mL for all analytes when extracting 100 μ L of urine. To increase the sensitivity of the assay it was possible to scale up the extraction procedure using larger matrix volumes (500 μ L) in combination with larger column formats. No internal standards were used during method development and these data are not intended to demonstrate a validated analytical method.

Conclusion: We present a simplified approach for extraction of various benzodiazepines demonstrating reproducible recoveries >75% and limits of detection of 1-10 ng/mL from 100 μ L urine in a 96 well assay. Method scale-up to accommodate larger specimen volume is possible to attain lower limits of detection.

Key Words: Supported Liquid Extraction, Benzodiazepines, Sample Preparation

Interpretation of Lateral Flow Immunoassay Drug Test Results: Evaluation of the Drug Panel Reader

Sirpa Mykkänen¹, Åse Karttunen², Eino Puhakainen², **Teemu Gunnar**^{1,*}

¹National Institute for Health and Welfare, Helsinki, Finland; ²HUSLAB, Helsinki University Central Hospital, Helsinki, Finland

Introduction: Urine based screening tests for multiple drugs of abuse range from simple immunoassays to complex analytical procedures. In lateral flow tests, a drug positive and negative urine specimen can be rapidly detected by colored lines or by the absence of lines in the specific test line region of the strip. In general, test lines are being detected by sight.

Electronic imaging of a test device provides an interesting possibility for non-subjective evaluation of the test result, for data storage and for subsequent introduction to, e.g., hospital data bases. In the Drug Panel Reader, image acquisition data defines exposure time, image size and the captured image position of the image sensor. Data is transferred between a laptop and the reader module via USB connection. Analysis of the images is done in the laptop. A fixed threshold can be manually set to each drug group for non-subjective interpretation of a test result.

Objectives and Methods: The aim was to test the usability and reproducibility of the Drug Panel Reader (prototype device developed by VTT Technical Research Centre of Finland in co-operation with Abcell Oy). The immunoassay drug tests used were Innovacon Multi-Drug ten panel strip tests. Under laboratory conditions, drug-free urine was spiked with 13 target compounds detected by the Innovacon device and drug tests were carried out according to the manufacturer's instructions. Fifty-five tests were performed, including five test replicates at different spiked urine concentrations (cut-off value informed by the manufacturer, as well as $\pm 50\%$ and $\pm 25\%$ of cutoff value in blank urine, in addition to blank urine). Target compounds were divided into two distinct test solutions to avoid any cross-reactivity between compounds. Three images with three distinct Drug Panel Reader instruments were taken from each test (990 images in total).

Results and Conclusions: Following threshold values (at the cut-off level) were obtained based on average values of the above-mentioned measurements (concentration, ng/ml; threshold): D,L-amphetamine (3000; 1.8), methadone (300; 3.2), morphine (300; 6.4), oxycodone (100; 4.6), oxazepam (300; 5.8), nortriptyline (1000; 3.1), benzoylecgonine (300; 3.8), MDMA (2000; 3.3), tetrahydrocannabinol carboxylic acid (50; 12.4) and buprenorphine (300; 6.4). For some drugs, there were single readings, which were also positive for -25% and even -50% of cutoffs. All these readings were significantly different from blank samples. This exemplifies qualitative nature of testing and lower than manufacturer's informed cutoff limit sensitivity for (non-glucuronated) target compounds. Correlation coefficients of variation (CV) were up to 8.7% (nortriptyline) for the same test strip measured by the same reader device, but commonly below 5% for the test substances. In general, CV values were also smaller for the same test strip evaluated by different reader devices (below 15% at the cut-off level) than for the multiple test strips (n=5 each) analyzed by one reader device (up to 33%; methadone). Repeatability of the latter was also compound-dependent: MDMA had CVs below 10%, while methadone and morphine had values over 20% for all three devices.

Drug panel reader is beneficial for easy, reproducible and objective interpretation, as well as for electronic data storage of test results and for traceability. Nevertheless, variability of test strips used remains a challenge that should be overcome. Furthermore, general limitations of on-site testing devices, such as false positives and negatives, and inability to detect all toxicologically relevant compounds should be bear in mind.

Key Words: Drugs of Abuse, Urine Immunoassay Testing, Drug Panel Reader

Detection of Synthetic Urine in Workplace Drug Testing Specimens

Carl A. Linden

Diagnostic Laboratory Services, Inc., HI, 96701, USA

Objectives: From the beginning of drug testing, substance abusers tried to avoid detection, presenting challenges to laboratory specimen collectors and analysts. Submission of synthetic rather than authentic urine became, at least in some geographical areas, far more prevalent than usage of adulterant additives. This presentation summarizes our laboratory's initial physical identification of suspected synthetic urine from daily workplace drug testing samples. Suspicious samples were analyzed for low level uric acid and normalized to creatinine to obtain a ratio identifying synthetic urine specimens.

Materials and Methods: Initially, samples suspected of being synthetic were identified by unusual color, clarity and absence of foaming when shaken. These samples were analyzed for creatinine, urea and uric acid. The most common missing component in these samples was uric acid. Subsequently, 250 pre-employment and random forensic workplace urine drug testing samples were analyzed for uric acid and creatinine on an Olympus AU680 analyzer to establish an average population uric acid / creatinine ratio (UA/CR). An invalid-specimen threshold UA/CR ratio was established at 30% below the lowest observed population ratio.

Quantification of uric acid was performed on 0.5 mL aliquots of random human urine utilizing a spectrophotometric analysis developed by Beckman Coulter (modification of the Fossati method) for the Olympus (now Beckman-Coulter) AU 680 automated chemistry analyzer. Creatinine was also measured spectrophotometrically on the same instrument, and aliquot, utilizing a Siemens modified Jaffe reaction.

Results: The average random population (n=254) tested had an average Uric Acid / Creatinine ratio of 0.43, Median of 0.41, Std. Dev. 0.15, Range 0.15 – 1.23. The discriminated UA/CR ratio was established at < 0.10 to identify synthetic urine. In the absence of a confirmatory method, these specimens were reported as Invalid, in the context of the definition from the Dept. of Health and Human Services Mandatory Guidelines for Federal Workplace Drug Testing Programs (2004). The synthetic urine population (n=319) had an average creatinine value of 76.5 mg/dL and uric acid level of 0.3 mg/dL, resulting in an average UA/CR ratio less than 0.004.

Conclusion: In approximately 10,000 forensic urine workplace drug tests collected in the Hawaiian Islands, Guam and Saipan and analyzed from Oct 1, 2010 to March 31, 2011, nearly 2% were synthetic urine. To the best of our knowledge, we believe only our laboratory and at two Oregon laboratories are testing for synthetic urine in the U.S. If this percentage of synthetic urine was extrapolated to the entire country, then there is a high probability that a large number of individuals are "beating the drug test." This potentially is a problem far exceeding that caused by any urine adulteration product currently being tested in U.S. drug testing laboratories.

Key Words: Workplace Drug Testing, Synthetic Urine, Uric Acid/Creatinine Ratio

Specimen Validity Testing (SVT)-Analyzing pH, Creatinine Concentration and Specific Gravity in Korea**Beom Jun Ko***, Min Kyoung Kim, SungIl Suh, and Moon Kyo In

Drug Analysis Laboratory, Supreme Prosecutors' Office, 706, Banporo, Seocho-gu, Seoul 137-730, Korea

Introduction: Urine creatinine concentrations are commonly checked in forensic drug tests to evaluate the validity of a urine specimen for drugs of abuse detection. Creatinine is a break-down product of creatine phosphate in muscle and is usually produced at a relatively constant rate by the body depending on muscle mass, filtered through the kidneys and excreted in urine. Creatinine concentration is gender, age and sampling time dependent. Creatinine concentrations of first morning urine are highly variable, thus, it is difficult to determine cut-off values of normal creatinine concentrations. The proposed cut-off values of creatinine concentration vary from 5 to 30 mg/dL (SAMHSA, 5 mg/dL; Fraser A.D., 20 mg/dL; Goll M., 25 mg/dL; Needleman S.D., 30 mg/dL). To resolve this discrepancy, in 2005 the Department of Health and Human Services of the USA released specimen validity testing (SVT) guidelines to determine, if a urine specimen is dilute or has been adulterated or substituted. SVT includes specific gravity, pH, nitrite, chromium (IV), halogen, glutaraldehyde, pyridinium chlorochromate and surfactant.

Objective: We analyzed urine creatinine concentrations, pH, and specific gravity specimens to test for the validity of urine specimens in Korea, according to the partial SVT regulation.

Materials and Methods: 353 urine specimens were received by the Prosecution Service and stored at 4°C before analysis. The specimens were analyzed without centrifugation. Urine creatinine was determined in a 200 µL specimen by the Jaffe method with the Cobas C311 system (Hitachi). Urine pH and specific gravity (specimen volume 2.0 mL) were analyzed by reflectance colorimetry with URISYS 2400 (Hitachi). We used the definition of the US DHHS' SVT to establish SVT; an adulterated specimen in case of pH was <3 or ≥11. A substituted specimen was defined as a creatinine concentration <2 mg/mL and specific gravity is ≤1.0010 or ≥1.0200. A dilute specimen was defined as a creatinine concentration ≥2 mg/dL but <20 mg/dL and the specific gravity is >1.0010 but <1.0030.

Results: Urine creatinine concentrations were 6.6-410.6 mg/dL; pH was 6.5-9.0. The specific gravity ranges were 1.001-1.032. Among 353 samples, 12 samples were suspected to be dilute and 4 samples to be substituted specimens.

Conclusion: We validated urine specimens for dilution and/or adulteration received by investigators of the Prosecution Service and analyzed urine creatinine concentrations, pH, and specific gravity according to SVT standards.

Key Words: Specimen Validity Testing, Creatinine, Specific Gravity

P189

WITHDRAWN

Potency of Illicit Cannabis in Japan

Toshiyuki Takagi^{*1}, Rikiya Aoki², Yoshio Tokieda³, Mamoru Akutsu⁴, Yasuharu Kawase⁵, Tadashi Kataoka⁶, Yukari Tsumura⁷, Tomomi Mizuno⁸, Masakatsu Fukada⁹, Hiroshi Fujii¹⁰ and Kazumi Kurahashi¹¹. ¹Narcotics Control Department, Kinki Regional Bureau of Health and Welfare, Ministry of Health, Labour and Welfare (Kinki NCD), Osaka, Japan; ²Hokkaido NCD; ³Tohoku NCD; ⁴Kanto NCD; ⁵Yokohama Branch; ⁶Tokai NCD; ⁷Kobe Branch; ⁸Chugoku NCD; ⁹Shikoku NCD; ¹⁰Kyushu NCD; ¹¹Okinawa Narcotics Control Office

Objectives: In recent years, increased ‘cannabis potency’, or delta-9-tetrahydrocannabinol (THC) content in cannabis products, has been reported in many countries. However, there is no large-scale study on THC levels of Japanese illicit cannabis. The aim of this study is to survey cannabis potency in Japan.

Materials and Methods: Seized cannabis samples after criminal trials were surveyed. They were transferred from regional prosecutors’ offices to the Minister of Health, Labour and Welfare via NCDs within a few months or years after seizure. Sampling period was from April 2010 to March 2011. Cannabis samples were classified into marijuana, whole weed, hashish, hash oil and others (mixture with tobacco or herbs, burned residue, etc). Marijuana samples were further classified into buds with seeds, buds with no seeds, leaves and others (stems or twigs). The number or weight of each sample was recorded. Concentrations of THC, CBN, and CBD in marijuana samples exceeding 1g were determined according to the UNODC’s Recommended Methods for the Identification and Analysis of Cannabis and Cannabis Products’ (2009).

Results: Only half the samples from the survey period have been summarized at the time of submission of this document. The number of post trial cannabis samples was 3866, of which 2681 were marijuana, 584 hashish, and 486 weed. Further classification of marijuana seizures showed that 68% of the samples were seedless buds, representing 87% of the weight. The average THC levels were 3.3% in buds with seeds, 8.6% in seedless buds, and 2.6% in leaves. The highest THC level was found in a seedless buds sample at 19.9%.

Conclusion: Seedless buds, commonly known as ‘sinsemilla’, represent the majority of marijuana seizures in Japan. The highest THC level observed was 19.9%. These facts indicate distribution of ‘high potency cannabis’ in Japan. Since the post trial cannabis samples have been stored for long periods of time the THC content is expected to be lower than that at the time of seizure. The authors are attempting to estimate the THC levels before storage. This work was supported by a Health and Labor Sciences Research Grant from the Ministry of Health, Labour and Welfare.

Key Words: Cannabis, THC, Japan

Frequency and Type of Synthetic Cannabinoids Analyzed in the Council of Forensic Medicine-Istanbul Narcotic Department, Turkey

Fatma Gürdal*¹, Şenol Korkut¹, Yasemin Göçer¹, Esra Küçükibrahimoğlu¹, Rezzan Gülhan Aker^{1,2}, Mahmut Aşıröz^{1,3}

¹Council of Forensic Medicine, Istanbul Chemistry Department Narcotic Division, Istanbul, Turkey; ² Marmara University School of Medicine, Department of Pharmacology, Istanbul, Turkey; ³ Celal Bayar University, Department of Forensic Medicine, Manisa, Turkey

Objectives: In recent years, synthetic cannabinoids are frequently observed in seized materials all over the world. These new generation designer drugs, also known as “Spice” or “Legal Highs,” can easily be obtained via the internet and are in sold mixed with herbal substances. In this study, we aimed to evaluate the type and detection frequency of synthetic cannabinoids sent to be analyzed in our laboratory over a 10-month period between August 2010 and April 2011.

Materials and methods: Herbal materials sent by judicial authorities to The Council of Forensic Medicine-Istanbul Narcotic Department between August 2010 and April 2011, were analyzed in the study. All materials were analyzed by physical examination, thin layer chromatography and GC-MS (Agilent 6890GC/5973MS inert, with 30m HP-5MS column).

Results: A total of 1171 herbal substances were analyzed during the 10-month investigation period and 1156 of them (98.7%) contained synthetic cannabinoids. We found both JWH-018 and JWH-081 in 760 (65.7%) samples out of 1156; JWH-018 alone in 382 (33%); CP47,497 (C8) in 5 (0.4%); both CP47,497 (C8) and JWH-018 in 7 (0.6%) samples; JWH-250 alone in 2 (0.2%) samples. Samples material had different package names such as “Bonzai Aromatic Potpori” (n=755), “Bonzai” (n=313), “Heaven” (n=14), “Aromatic Incense,” (n=6), “Yukatan Fire” (n=7), “Tribal Warrior Ultimate” (n=5), “Jamaican Gold” (n=43) and “Jamaican Sprit” (n=5). All Bonzai packages (n=313) contained JWH-018 while 2 samples contained JWH-250. JWH-018 along with JWH-081 was detected in “Bonzai Aromatic Potpori” (n=755) and in “Jamaican Spirit” (n=5). All “Yukatan Fire” packages contained JWH-018 with CP47,497 (C8). “Tribal Warrior Ultimate” packages had CP47,497(C8) (n=5). The rest of packages with different names had JWH-018.

Conclusions: JWH-018 was the most frequent type of synthetic cannabinoids (detected in 98.7% of 1156 samples). “Bonzai” and “Bonzai Aromatic Potpori” were the most common product name amongst the herbal products sent to our laboratory (n=1068). Although some of these synthetic cannabinoid compounds are banned by law, there is not an “analogue or derivative” clause established in Turkey yet. The increase use of different derivatives, lack of analytical data and reference standards for analysis, lack of information on metabolism and metabolites for toxicological analysis in human subjects are important problems that need to be solved.

Key words: Synthetic Cannabinoids, JWH, Spice, Bonzai

Prevalence and Co-Occurrence of Active Ingredients of 'Legal Highs'**Bogumila Byrska*** and Dariusz Zuba

Institute of Forensic Research, Krakow, Poland

Objectives: 'Legal highs' encompass a wide range of products, from herbal mixtures to synthetic drugs. These preparations are dangerous for customers, because little is known about metabolism and toxicology of the active ingredients. Growing popularity of 'legal highs' has received considerable attention and perceived threats of toxicity call for new methods of analysis, identification and gathering more information about the highly diverse and unpredictable market for these recreational drugs. The aim of this study was to identify active ingredients of 560 different 'legal high' products and to examine their common components. Moreover, the changes in composition of these preparations as a consequence of recent legislative development in Poland were studied.

Materials and Methods: Powders, tablets and capsules were homogenized, then dissolved in methanol and centrifuged. Herbal mixtures were prepared by ultrasonic-assisted extraction with ethanol. The extracts were analyzed by chromatographic methods (GC-MS, HPLC/DAD, LC-QTOF/MS).

Results: The main active ingredients of powders, tablets and capsules were: MDPV (27%), butylone (19%), TFMPP (14%), mephedrone (13%), 4-MEC (13%), BZP (11%), pFPP (10%), MDPBP (7%), buphedrone (6%), MeOPP (5%), pentedrone (4%), MPPP (4%), methylone (4%), methedrone (3%), pentylone (3%), DBZP (3%), MBZP (3%), naphyrone (2%), mCPP (2%), DMAA (2%), BMDP (2%), 4-FMC (2%), M-Alpha (1%), 4-FA (1%), 2-CE (1%), 2-CB (1%), p-FBT (0.5%). Caffeine, lidocaine, nicotinamide, D2PM, fenfluramine, amphetamine and acetaminophen were also discovered. Main active ingredients detected in herbal mixtures were: JWH-081 (15%), JWH-018 (12%), JWH-122 (9%), CP47.497-C8-Homologue (7%), RCS-4 (7%), JWH-073 (6%), JWH-250 (6%), JWH-210 (5%), salvinorin A&B (4%), AM-694 (2%), JWH-251 (1%), JWH-019 (1%), CRA-13 (0.6%), oleamide (0.6%), mitragynine (0.6%), JWH-203 (0.2%).

Conclusions: Graphic visualization enabled the detection of patterns among substances. Single cathinones, piperazines, phenylethylamines and synthetic cannabinoids were rarely detected. Usually, mixtures were composed of substances from the same chemical class. The most common combinations were: BZP-TFMPP, butylone-MDPV-lidocaine and JWH-081-JWH-250. The profile of the active ingredients changed with amendments in the anti-drug law, but in some instances even banned substances were discovered in 'legal highs'. The composition of 'legal highs' was highly variable and unpredictable, so accidental overdose is a strong possibility.

Key Words: 'Legal Highs', Designer Drugs, Graph-Based Visualization

Advanced LC-MS Approaches for the Detection of Synthetic Cannabinoids in Unknown Samples

Megan Grabenauer*, Wojciech L. Krol and Brian F. Thomas

RTI International, 3040 Cornwallis Road, Research Triangle Park, NC 27709, USA

Introduction: Synthetic cannabinoids, such as JWH-018, CP 47,497, and HU-210, are commonly found in herbal incense blends sold at head shops and on the Internet, often under the brand name of “Spice.” Several countries have passed bans on the most popular of these compounds, but as bans on specific compounds go into effect, manufacturers substitute closely related legal analogues for the newly banned substances, creating a constantly moving analytical target.

Objectives: The focus of this work was to investigate advanced LC-MS approaches for synthetic cannabinoid detection, and identify a universal approach to analyze samples containing unknown synthetic cannabinoid additives.

Methods: 26 herbal products purchased in 2010 from “head shops” in the Raleigh, Durham, and Chapel Hill areas were subjected to an ethanol extraction and analyzed using a Synapt G2 high definition mass spectrometer (HDMS) quadrupole time of flight (Q-TOF) instrument interfaced to an Acquity ultra performance liquid chromatography (UPLC) system. The set of JWH compounds has a narrow residual mass range. Accurate mass filtering (AMF), therefore, was explored as a method to identify analog JWH compounds present as unknown peaks in the LC-MS chromatograms. A data independent MS^E acquisition method, in which low and high collision energy data are collected nearly simultaneously for every m/z, was investigated for its utility in post acquisition data analysis.

Results: JWH-018 was the most commonly observed synthetic cannabinoid, appearing as a major component in 80% of the samples tested. JWH-073, JWH-081, and JWH-250 were also present in several of the samples. AMF was deemed unnecessary to identify the predominant synthetic cannabinoids in each product, as they were easily detected in the LC-MS total ion current (TIC) chromatograms by their large signals compared to background. The technique, however, is useful as a tool to detect very low synthetic cannabinoid concentrations in complex mixtures, and for detecting metabolites in biological fluids. This method may also prove useful for source fingerprinting or to confirm a small amount of an illegal substance (present as an impurity from synthesis) in a product containing new synthetic analogs to circumvent current bans. MS^E acquisition proved useful for capturing the most information in the least amount of experimental time. Sufficient signal was obtained to quantify compounds using a pseudo-selected reaction monitoring (SRM) method, while at the same time acquiring full scan fragment ion spectra, enabling daughter ion scanning. With daughter ion scanning, structurally similar JWH compounds were easily identified by the presence of characteristic fragment ions.

Conclusions: Both an MS^E acquisition method and AMF can help identify new analogs to currently banned substances when faced with an unknown sample.

Key Words: JWH, Spice, Mass Spectrometry, Cannabinoid

Quantitation of Esterified and Non-Esterified Steroids in Oil-Based Injectables with SPE-UHPLC-DAD**Härtel, C.*^{1,2}**, Pütz, M.¹, Müller, L.¹ and Karst, U.²¹Federal Criminal Police Office, Forensic Science Institute, Wiesbaden, Hesse, Germany; ²Westfälische-Wilhelms-Universität, Münster, North-Rhine Westphalia, Germany.

Objectives: Following the amendment of the German pharmaceuticals law (Arzneimittelgesetz) and submission of a new decree (stipulation of penologic relevant amounts of doping substances, DmMV) in Germany new competences were assigned to the Federal Criminal Police Office (BKA) in the area of doping agents. Due to this new regulation it was necessary not only to identify the doping agent but also to quantify. For qualitative analyses of oil-based doping agents there are already numerous methods published, but for quantitative analyses only few literature is known [1]. The aim of this work was to establish a quantitative method for the main anabolic doping agents in oil based injectables.

Materials and Methods: Experiments were performed using a Shimadzu UFLC system (prominence, gradient pump, auto sampler, column oven, diode array detector (DAD)) equipped with a Waters Acquity HSS T3 column (2.1 x 100 mm, 1.8 µm). A gradient of acetonitrile, water and formic acid with a flow rate of 0.5 mL/min proved to be optimal. The temperature was set at 30 °C. Quantitation was performed by measuring absorbance at 245, 280 or 340 nm. Three different types of solid phase extraction (SPE) phases (LiChrolut RP-18 E 500 mg, LiChrolut EN 500 mg, Discovery DSC-18 500 mg) were tested. Oil-based injectables were mixed with an internal standard dissolved in benzyl alcohol. An aliquot of the oil was directly transferred to the SPE cartridge, which subsequently was washed with 5 mL of methanol. The obtained methanol phase was analyzed with the developed UHPLC-DAD method.

Results and Conclusions: It was possible to base-line separate and quantify testosterone acetate, testosterone propionate, testosterone phenyl propionate, testosterone enantate, testosterone isocaproate, testosterone cypionate, testosterone decanoate, testosterone undecanoate, metandienone, testosterone, methyl testosterone, danazol, trenbolone, trenbolone acetate and trenbolone enantate in 17.5 min. SPE phase Discovery DSC-18 was best suited for sample preparation. Extraction efficiencies for all analytes were between 95 and 99%. The developed method was fully validated and successfully applied to forensic case work samples. The relative standard deviation (RSD) for the repeatability ranged from 0.1 to 1.1%. The RSD for the intermediate imprecision ranged from 0.3 to 1.5% for the retention times and from 4.0 to 6.0% for the concentrations. The linearity of the method ($R^2 > 0.999$) was assessed for the concentration range 5-500 µg/mL by injection of pure standard solutions. LODs and LOQs were calculated using the calibration curve and the confidence belt, pursuant DIN 32 645, and ranged from 3 to 12 µg/mL (LOD) and from 7 to 18 µg/mL (LOQ).

References:

[1] R. Gonzalo-Lumbreras, M. A. Garcia-Miguens, R. Izquierdo-Hornillos, J. Pharm. Biomed. Anal. 38 (2005) 757-762.

Key Words: Doping, Esterified Anabolic Steroids, UHPLC-DAD

Composition Analysis of “Legal Highs” by GC-EI-MS for Medico-Legal Purposes**Sebastian Rojek***, Martyna Maciów and Małgorzata Kłys

Chair and Department of Forensic Medicine Jagiellonian University School of Medicine, Kraków, Poland

Introduction: “Legal highs” are psychoactive substances widely available “smart shops” and are structurally modified to circumvent legal prevention of drugs of abuse, thus making them quasi-legal substances. Inspections of “smart shops” began in response to the increasing new drug market in Poland in 2010 and also due to the amendment to the Act on the prevention of drugs of abuse. “Legal highs” obtained from “smart shops” were examined to identify composition; these findings will assist interpretation of clinical and medico-legal cases.

Objectives: The aim of this investigation was to develop a proprietary unique mass spectral database based on the analysis of certified references. Additionally, the database would be employed in analyses of “legal high” forensic samples.

Material and Methods: Methanolic certified standard solutions (10 µg/mL) of designer drugs were analysed in order to create a unique mass spectral library. Powders, tablets (50 mg) and herbal mixtures (100 mg) were prepared by extraction with methanol (2.5 mL and 2.0 mL, respectively) over night. The analysis of standards and 943 forensic samples was performed by gas chromatography mass spectrometry (GC-MS), by 7890A GC and 7000 triple quadrupole MS (Agilent Technologies, USA). GC-MS was used in electron impact (EI) mode at 70 eV. The analysis was performed using a capillary column (HP-5ms-UI, 30m x 0.25 mm x 0.25 µm) and splitless mode injection. An initial column temperature of 60 °C was held for 1 min, and was increased at a rate of 40 °C/min to 325 °C and held for 12 min. The total run time was 19.63 min. Helium at a constant pressure of 14.9 psi was used as a carrier gas. The data were obtained in the full scan mode with a scan range of m/z 50-600.

Results: The created library contained 53 mass spectra from designer drugs, including 15 synthetic cannabinoids, 8 cathinones, 7 phenethylamines, 5 piperazines, 2 pyrrolidines and 16 unclassified compounds. In 540 samples of tablets and powders, we observed piperazine derivatives: 1-benzylpiperazine (BZP) in 5.0% of cases, 1-methyl-4-(phenylmethyl)piperazine (MPMP) in 9.8%, 1-(3-trifluoromethylphenyl)piperazine (TFMPP) in 10.9%, para-fluorophenylpiperazine (pFPP) in 5.2%; cathinone derivatives: N-ethylcathinone in 2.4%, buthylone in 18.5%, ethylone in 1.7%, methylone in 1.9%, buphedrone in 3.1%, flephedrone in 3.1%; pyrovalerone derivatives: 3,4-methylenedioxypropylpyrovalerone (MDPV) in 18.7% and naphyrone in 1.9% of cases. In 403 samples of herbal mixtures, we found synthetic cannabinoids: AM-694 in 5.4% of samples, JWH-019 in 5.7%, JWH-073 in 2.7%, JWH-081 in 29.8%, JWH-122 in 20.3%, JWH-210 in 7.4%, JWH-250 in 4.7% and RCS-4 in 28.8 %. In few samples of herbal mixtures, MDPV and lidocaine were found.

Conclusion: The developed GC-EI-MS method established a unique proprietary library of mass spectra, which may be useful for identifying components of “legal high” in medico-legal investigations. Spectral determination is vital for the identification of new designer drugs in non-fatal and fatal poisonings for clinical and medico-legal purposes.

Key Words: “Legal highs”, GC -MS, Medico-Legal Cases

Enantioseparation of Methylamphetamine by Capillary Electrophoresis: a Survey of the Synthetic Route of Methylamphetamine Samples Seized in the Australian Capital Territory (ACT)

Arthur Jones¹, Dennis Pianca², Julieanne Dougherty², and Tamsin Kelly^{1*}

¹National Centre for Forensic Science, University of Canberra, ACT, Australia; ²ACT Government Analytical Laboratory, Health Protection Service, ACT Health, Australia

Objectives: Illicit production of methylamphetamine (MAMP) falls into two categories: reduction of ephedrine/pseudoephedrine (which produces the *S*-(+) isomer of MAMP) or synthesis from phenyl-2-propanone (P2P) or related compounds (which produces a racemic mixture of the isomers). Identification of the isomers present in seized MAMP provides intelligence on the production route used. Project STOP is an initiative that aims to reduce the diversion of pseudoephedrine based pharmaceuticals into the illicit production of MAMP. Within the Australian Capital Territory (ACT), all pharmacies have registered with the initiative since December 2007, while 73% of pharmacies have registered nationally as of 30 June 2009 [Australian Crime Commission, Illicit Drug Data Report 2008 –09, 2010]. The aim of this study was to develop an optimized chiral capillary electrophoresis method for MAMP isomers using β -cyclodextrin derivatives. The validated method was then applied to survey past and present MAMP seizures in the ACT. The primary focus was to provide information on any changes in production methods over this period and to potentially provide some insight into the effectiveness of the recently introduced controls to reduce the availability of pharmaceutical pseudoephedrine for MAMP production through the national implementation of Project STOP.

Methods: The chiral separation method used a 50 μm x 64 cm fused silica capillary, with 150 mM phosphate buffer containing 10 mM heptakis (2,6-di-*O*-methyl)- β -cyclodextrin at a pH of 3.6. A voltage of 25 kV was applied with a temperature 15°C and UV detection at 195nm. Samples underwent hydrodynamic injection (2 sec at 50 mbar) and the analysis time was 25 minutes. Seizure samples (100 mg) were dissolved in 1 mL of methanol, vortexed (5 min), sonicated (10 min) and centrifuged (2465 g for 10 min), prior to dilution to either ~20 $\mu\text{g/mL}$ or ~80 $\mu\text{g/mL}$ (based on purity data).

Results: A total of 81 MAMP seizures were analyzed. During the validation, the intra-day ($n = 5$) and inter-day ($n = 5$) inaccuracy (%) and imprecision (% CV) of the % peak area of the isomers for different isomeric ratio QC samples were less than 5%. There were 29 samples pre-Project STOP and 52 samples post-Project STOP. The percentage of 100% *S*-(+)-MAMP (indicating ephedrine/pseudoephedrine reduction) samples pre- and post-Project STOP was 89.7 % and 82.7 %, respectively. It was determined using a two sample t-test (t stat = 0.27, $df = 65$, $p = 0.79$) that there was no difference between MAMP isomer ratios observed during the two periods.

Conclusions: These results agree with current trends in the Australian illicit drug market, which do not show any decrease in the availability of ephedrine/pseudoephedrine for domestic MAMP production. This may indicate that the current market is swamped with MAMP derived from pseudoephedrine sourced from alternate means (e.g. illicit importation of pseudoephedrine). Alternatively, pharmaceutical preparations of pseudoephedrine may be sourced from neighbouring jurisdictions, such as New South Wales (NSW). While Project STOP may be preventing diversion of pharmaceutical pseudoephedrine, based on this preliminary study it does not appear to be having an effect on the large scale illicit production of MAMP samples seized in the ACT.

Keywords: Methylamphetamine, Chiral Capillary Electrophoresis, Project STOP

A Fast and Inexpensive Procedure for the Isolation of Synthetic Cannabinoids from 'Spice' Products Using a Flash Chromatography System

Bjoern Moosmann*, Stefan Kneisel and Volker Auwärter

Institute of Forensic Medicine, University Medical Center Freiburg, Freiburg, Germany

Objectives: The tremendously booming market of 'herbal highs' brings up new challenges in forensic toxicology. The synthetic cannabinoids are often substituted for one another with high frequency to subvert regulations, making it difficult to promptly obtain pure reference substances for forensic analysis or toxicological testing. The aim of this work was to extract and purify various synthetic cannabinoids with different physico-chemical properties from 'Spice' products. In addition, by using inexpensive solvents and if possible seized smoking mixtures, the procedure should remain less expensive than obtaining commercially available standards.

Materials and Methods: The substances were extracted from the 'herbal' mixtures over a 24 hour period with ethanol. Afterwards, the sample was loaded on a RediSep® Rf Gold C18 column (15.5g) with a 'dried solid sample load technique'. Separation of analytes was achieved by using a CombiFlash® Rf apparatus (Teledyne Isco, Lincoln, USA) and gradient elution (mobile phase A: 0.55% formic acid in water; mobile phase B: methanol). Measuring the average absorbance of all wavelengths as well as the specific wavelength of 207 nm allowed for collecting the fractions. This particular value was chosen, due to the high absorbance of all substances at this wavelength. Final purification was done by alkaline (for aminoalkylindoles) or acidic (for cyclohexylphenols) extraction with tert-butyl methyl ether. The purity was tested by means of GC-MS and NMR.

Results: In 'herbal' mixtures containing CP-47,497-C₈ we were able to separate the two diastereomers with a purity of 99.6% for the cis and 99.2% for the trans isomer. For the various tested synthetic cannabinoids (namely JWH-015, JWH-018, JWH-019, JWH-073, JWH-122, JWH-203, JWH-210, JWH-250, JWH-251, RCS-04, AM-2201) the purity also exceeded 99%. Furthermore, it was possible to isolate the respective synthetic cannabinoids from products containing 3 or even 4 different compounds (e.g. JWH-018, RCS-04 and CP-47,497-C₈ or JWH-250, JWH-018, JWH-122 and CP-47,497-C₈).

Conclusions: The described method provides a fast, easy and inexpensive way to isolate synthetic cannabinoids from 'Spice' products. The method facilitates gaining reference substances for timely development or enhancement of analytical methods in forensic toxicology. This is needed especially when new synthetic cannabinoids with yet unknown structures emerge. Additionally, it is possible to obtain larger quantities of substances for toxicity screening assays. In the case of the diastereomers of CP-47,497-C₈, investigation of the toxicity of each of the cis and trans isomer is facilitated.

Key Words: Synthetic Cannabinoids, Flash Chromatography, Reference Compounds

The Identification of Vapours from Illicit Cocaine Samples Using Static Head-Space Gas Chromatography Mass Spectrometry (HS-GC-MS)

Karen Rofe * and Clare McCluskey

Home Office Centre for Applied Science and Technology, Sandridge, UK

Introduction: Illicit cocaine seizures have a very distinctive odor in comparison to pharmaceutical grade cocaine. Identification of the substances causing this odor could allow for the possibility of new or improved non invasive vapor detection methods for illicit cocaine to be developed in the future. Both cocaine base and cocaine hydrochloride have low vapor pressures of 8.67×10^{-8} torr [¹] and 1.4×10^{-8} torr at 20°C [²] respectively, therefore it is unlikely they cause the odor. Often, cocaine is responsible for only a small percentage of the overall illicit seizure; the composition can vary considerably due to different synthetic routes being used during cocaine production causing the presence of different impurities, such as solvent residues and co-extracted alkaloids, or different diluents and cutting agents such as benzocaine and caffeine.

Objectives: The aim of this work was to use Static Head-Space Gas Chromatography-Mass Spectrometry (HS-GC-MS) to gain an improved understanding of what substances may be causing the odor by analyzing the headspace (vapor phase) from illicit cocaine seizures. Compounds of interest should be 1) closely related to cocaine 2) have higher vapor pressures than cocaine and 3) common components within many different illicit seizures.

Materials and Methods: A method was developed to analyze 50 illicit cocaine samples using HS-GC-MS. The mobile phase used was ultra high purity helium with a column flow rate of 1ml/min. The split ratio was set at 20:1 with an injector temperature of 250°C and a syringe temperature of 100°C. The GC oven program was as follows: 35°C for 1 minute, then ramped to 300°C at 15°C/min and held for 1.33 minutes, total GC time of 20 minutes. Agitator temperature was 100°C, with a speed of 500 revolutions per minute and a cycle of 2 second agitations followed by rest periods of 4 seconds, for a total of 10 minutes. All identifications were confirmed using chemical standards.

Results and Conclusion: The method chosen gave good chromatographic separation between components. Initial results from analyzing the 50 samples identified that 86% of the samples contained methyl benzoate, 85% contained ecgonine methyl ester, 77% contained benzoic acid and 75% contained ecgonidine methyl ester. These have the potential to be 'marker compounds' for illicit cocaine detection. Future work will look at confirming the presence of these materials in a greater sample size and at lower agitator temperatures.

Key-Words: Head-Space, Cocaine, GC-MS

RP-HPLC Determination of Benzhexol Hydrochloride in Tablet Formulations and UrineRabie Saad Farag and **Ashraf Mohamed Ahmed***

Faculty of Science, Al-Azhar University, Cairo, Egypt and Medico-Legal Organization, Ministry of Justice, Cairo, Egypt

Introduction: Benzhexol stops salivation and reduces skeletal muscle tone and rigidity in Parkinson's syndrome, where it produces symptomatic relief and improvement of the patients' condition. Several high performance liquid chromatographic (HPLC) methods have been reported for the determination of benzhexol hydrochloride and its major metabolites.

Objectives: This study aimed to develop new, simple, sensitive and selective HPLC methods for benzhexol hydrochloride determination in pharmaceutical preparations and urine.

Methods: A new high performance liquid chromatographic method for the quantitative determination of benzhexol hydrochloride was developed using an octadecyl silica Li Chrosper 100 RP 18 column, and 250 mm× 4 mm i.d. with 5 µm particle size. Solutions were prepared monthly from Parkinol tablets (10 mg/tablet; El-Nile, Egypt) at a concentration of 100 µg/mL and stored at 4 °C. 0.50 mL urine was fortified with benzhexol hydrochloride to a concentration of 50–4000 ng/mL. The fortified urine was briefly mixed, and 5.0 mL chloroform added (containing tramadol hydrochloride 5-400 ng/mL as internal standard). After centrifugation at 2500 rpm for 10 min, specimens were refrigerated 10 min, the organic layer was decanted, evaporated and reconstituted with 0.50 mL mobile phase. 20 µL extracts were injected onto a C18 column HPLC–UV system. Urine was subjected to a pH adjustment to 5.0 by phosphoric acid. Several water-immiscible organic solvents were evaluated including ethyl acetate–hexane 30:70, toluene, cyclohexane–dichloromethane 40:60, ethyl acetate and toluene–hexane 80:20. We modified the acetonitrile percentage, as well as the mobile phase pH to choose the composition which gave the best column efficiency. Additionally, flow rate changes from 0.3 to 1 mL/min showed that column efficiency decreased as the flow rate increased. A flow rate of 0.6 mL/min was chosen when considering the chromatographic system and solvent economy. Varying the temperature between 10 and 50°C significantly altered column efficiency; therefore, a 30°C controlled temperature was chosen. Under these final conditions, more than 300 injections were achieved.

Results: Reversed phase chromatography was conducted using a mobile phase consisting of acetonitrile and water (50% v/v), adjusted to pH 5 using phosphoric acid and detection at 254 nm. The flow rate was 0.6 mL/min and the R_f of benzhexol hydrochloride was 7.418. The calibration curve was linear from 0- 2000 ng/mL. Average recovery was 100.04 % with a coefficient of variation of 0.89%. Thus, it was concluded that there was no significant difference for the assay which was tested within day and between days. The limit of detection (LOD) was 30 ng/mL and limit of quantification (LOQ) was 90 ng/mL.

Conclusion: This HPLC procedure is rapid and suitable for routine analysis. Satisfactory validation data were collected for linearity, precision, recovery and ruggedness, LOQ values allowed quantification of therapeutic concentrations. Results were in agreement with those of reference methods.

Key Words: Benzhexol Hydrochloride, Reversed Phase HPLC and C18 Reversed-Phase Column

P200

Acute Deliberate Organophosphate (Coumaphos) Poisoning with Intermediate Syndrome in a One Year Old Child

WK Kiat*

Toxicology Unit, St. Luke's Medical Center, Quezon City, Philippines

Objective: To report a case of acute organophosphate poisoning in a one year old child and development of intermediate syndrome eight hours after exposure.

Case Report: A previously healthy one year old child arrived at the emergency room with sudden onset of difficulty of breathing, cyanosis, excessive oral secretions, one episode of diarrhea and weakness. These symptoms were noted three hours earlier after ingesting allegedly contaminated powdered milk formula. Vital signs were observed as a blood pressure of 90/60, cardiac rate of 112 beats per minute, 12 respiratory cycles per minute and axillary temperature of 35.4°C. Blood gas analysis showed respiratory acidosis. Endotracheal intubation was immediately performed and mechanical ventilation implemented. The toxidrome of the patient was compatible with acute cholinergic excess; hence, a trial dose of atropine was given, resulting in some improvements. Eight hours later, neurological examination showed absence of deep tendon reflexes, no spontaneous respiration, no response to pain, flaccid muscle tone, no neck rigidity and lateralizing signs but with spontaneous eye opening. RBC cholinesterase was 0.057 delta pH/hr, which was significantly depressed. Atropine was given at 0.02 mg/kg intravenously until full atropinization was achieved and a packed RBC transfusion was administered. Twenty-four hours later, the patient was noted to have response to painful stimuli and spontaneous respiration. A repeat RBC cholinesterase determination showed a result of 0.25 delta pH/hr. Atropine was continued as needed. Testing was done on the allegedly contaminated milk using GC-MS, and Coumaphos was determined to be present in the sample. The patient was discharged after seven days.

Conclusion: Intermediate syndrome usually develops within 48-96 hours after acute cholinergic crisis due to prolonged inhibition of cholinesterases.

Key Words: Organophosphate, Intermediate Syndrome, Child

Reporting Two Suicidal Fatalities Due to the Ingestion of Chlorfenvinphos Formulations: Simultaneous Determination in Tissues of the Pesticide and the Petroleum Distillates by GC-FID/GC-MS

María Antonia Martínez* and Salomé Ballesteros

National Institute of Toxicology and Forensic Sciences, Ministry of Justice, C/ José Echegaray, 4, 28232-Las Rozas de Madrid, Madrid, Spain

Objectives: Chlorfenvinphos (CFVP) is an organophosphorus insecticide (OP) designated as a threat agent by the National Institutes of Health (NIH). However, there are few reported cases of poisonings in humans and none with postmortem toxicological analysis. We report two fatalities due to suicidal massive ingestion of a veterinary formulation containing CFVP and hydrocarbons/petroleum distillates.

Methods and Results: Case 1: A 24-year-old woman was found dead by her mother. According to the police records, the room was filled with a strange odour of solvents or pesticides and faeces. There was an empty bottle of Supona® near the body. The only relevant postmortem finding was that the lungs appeared congested and oedematous. Case 2: A 60-year-old man committed suicide by ingesting an unknown product. The van where he was found was completely closed and had a strong odour described as acid, sulphate or solvent according to different witnesses. The stomach of the victim was filled with abundant pale greenish fluid with a similar odour to that presented in the vehicle. The simultaneous toxicological screening and quantitation of CFVP and petroleum distillates [a mixture of trimethylbenzene isomers (TMBs)] was performed by means of gas chromatography with flame ionization detector (GC-FID) and confirmation was performed using gas chromatography-mass spectrometry (GC-MS). Disposition of CFVP and TMBs in different tissues were, respectively, as follows. Case 1: heart blood, 8.6 and 3.7 mg/L; liver, 60.0 and 33.4 mg/Kg; and stomach contents, 1,132 mg/L (792.4 mg total) and 377.0 mg/L (263.9 mg total). Case 2: heart blood, 4.4 and 6.5 mg/L; urine, 1.4 and and detected (< LOQ); bile 7.8 and 12.2 mg/L; vitreous 0.3 mg/L and detected (< LOQ); liver, 139.2 and 172.1 mg/Kg; and stomach contents, 76,168 mg/L (72,359 mg total) and 108,109 mg/L (102,703 mg total). Results of alcohol and other volatiles, abuse and therapeutic drugs were negative in both cases.

Validation data for CFVP in blood: Limits of detection and quantitation were 0.1 and 0.3 mg/L, respectively. Linearity of calibration curve was 0.997. Recoveries studied for two levels of fortification (1 and 5 mg/L) were >98% and precision intra-day <3%, respectively (n=5). Validation data for TMBs in blood: Limits of detection and quantitation were 0.03 and 0.1 mg/L, respectively. Linearity of calibration curve was 0.999. Recoveries studied for two levels of fortification (1 and 5 mg/L) were >91% and precision intra-day <4%, respectively (n=5).

Conclusion: Based upon the toxicological data along with the autopsy findings, the cause of death was determined to be in both cases CFVP formulation poisoning and the manner of death was listed as suicide. To the best of our knowledge, these are the first studies on CFVP fatal poisoning with tissue distribution data in humans. The findings highlight the importance of testing for pesticides and hydrocarbons/petroleum distillates in order to clarify the source of poisonings.

Key Words: Chlorfenvinphos, Trimethylbenzenes, Poisoning

Antidepressants in Urine Using the Triage® TOX Drug Screen Fluorescent Immunoassay Followed by Confirmation Via Direct Injection LC-MS/MS

Beatrice Avalos¹, Normand Hebert¹, Lupe Mejorado¹, **Mariusz Banaszczyk***¹, Margaux Garnier², Cynthia Coulter² and Christine Moore²

¹Alere, San Diego, CA USA; ²Immunalysis Corporation, Pomona, CA, USA

Introduction: Tricyclic antidepressants (TCA) are used for the treatment of anxiety disorders, mild to moderate pain as well as depression; however there are serious negative side-effects associated with their routine use, including dizziness, drowsiness, increased heart rate and even death. In suspected toxic cases, the availability of a rapid test is useful, but previous TCA immunoassays have suffered from poor specificity and/or false positive results.

Objective: To determine the contribution of glucuronidated urine metabolites towards a positive result using an immunoassay. Since glucuronide reference compounds are not commercially available, the identification of antidepressant metabolites in urine was carried out by LC-MS/MS before and after hydrolysis of the authentic specimens to characterize the immunoreactive assay.

Methods: Urine specimens were screened for the presence of TCAs using a fluorescent immunoassay (Alere Triage® TOX Drug Screen) calibrated with desipramine at a cut-off 1000µg/L. The positive specimens were analyzed for parent TCA drugs using a standard LC/MS/MS method consisting of an Agilent 1200 Series HPLC equipped with a Zorbax Eclipse XDB C18 (4.6 x 50mm x 1.8 µm) heated to 45°C, coupled to a 6410 triple quadrupole mass spectrometer, operating in positive electrospray ionization mode (ESI). Samples were eluted using a gradient of methanol and water with 0.2% acetic acid. A new LC/MS/MS method was developed for the identification and quantification of hydroxylated and demethylated TCA metabolites. In addition, using this new method, the same specimens were analyzed before and after hydrolysis with β-glucuronidase to assess glucuronide contributions to the positive results in the immunoassay.

Results: While the concentration of the measured antidepressants increased following hydrolysis, the most dramatic increases were for amitriptyline (AMI). 7 samples contained nortriptyline (NT), 10-OH-NT & AMI. Following hydrolysis, NT averaged an increase of 33%; 10-OH-NT, 118% & AMI over 3500%.

Conclusion: Quantitation of parent TCAs and their hydroxylated and demethylated metabolites by LC/MS/MS is insufficient when correlating with immunoassay based screening protocols like Triage® TOX Drug Screen, which also detects glucuronidated TCA metabolites. LC/MS/MS results generated after enzymatic hydrolysis of TCA metabolite glucuronides account for total amounts of TCAs and their metabolites, and such results correlate well with Triage® TOX Drug Screen results.

Key Words: Tricyclic Antidepressants; Fluorescent Immunoassay, LC-MS/MS

Target Screening of Drugs from Dried Blood Spot Samples Based on LC-MS/MS and On-Line Desorption

Estelle Lauer*, Julien Déglon, François Versace, Aurélien Thomas, Patrice Mangin and Christian Staub
Toxicology unit, CURML, Geneva and Lausanne, Switzerland

Objectives: Target screening needs rapid and comprehensive analytical tools to fulfill clinical and toxicological requirements. Regarding its sensitivity and selectivity, LC-MS/MS is now established as a mature technology for biomedical approaches. Furthermore, the concomitant use of data dependant acquisition (DDA) increases the information obtained in a single run by allowing the simultaneous acquisition of different MS/MS experiments. Due to the complex information obtained, the development of bioinformatic tools is an important issue for ensuring data handling. Compared to conventional sampling strategies generally based on venous collection, dried blood spot (DBS) provides an attractive alternative by being less invasive and more cost effective in terms of sample collection, shipment and storage.

Materials and Methods: The emphasis of DBS sampling, notably in pharmaceutical analysis, recently led to the development of novel solutions allowing high-throughput analysis. Based on these considerations, an analytical procedure was developed to screen and semi-quantify the most common drugs in blood, including cocaine, opiates, amphetamines, benzodiazepines, analgesics, antidepressants and neuroleptics using the on-line DBS concept coupled to a LC-MS/MS system [1]. Before analysis, DBS (i.e. 5 μ L) were manually punched out and directly introduced into the homemade prototype allowing for thirty samples to be successively desorbed toward a RP column (kinetex; C-18, 2.1 x 50 mm, 2.6 μ m i.d.). Detection was performed in DDA mode using a 5500 QTrap[®] triple quadrupole linear ion trap mass spectrometer (AB Sciex, Foster City, CA) operated in ESI mode. Multiple reaction monitoring (MRM) was used as the survey scan and enhanced product ion (EPI) scan as the dependent scan. Finally, drug identification was carried out by library search based on EPI spectra.

Results: This method allows the detection and identification of 90 drugs in a 6 min run time. Despite the use of a small sampling volume, the limit of detection (LOD) for most analytes is between 1 and 10ng/mL. Furthermore, the method was validated using quality controls and applied to real cases.

Conclusion: The present strategy may provide selectivity, sensitivity, and convenient throughput for target screening approaches.

References:

[1] Automated system for on-line desorption of dried blood spots applied to LC/MS/MS pharmacokinetic study of flurbiprofen and its metabolite. Déglon et al. J Pharm Biomed Anal. 2011, 54(2), 359-67

Key Words: Target Screening, DBS, LC-MS/MS

Application of Ultra High Pressure Liquid Chromatography Tandem Mass Spectrometry to the Analysis of Antiarrhythmic Drugs in Serum and Plasma

JoEtta M. Juenke¹, **Ronald L. Thomas***¹, Paul I. Brown¹, Gwendolyn A. McMillin^{1,2}, Kamisha L. Johnson –Davis^{1,2}

¹ARUP Institute for Clinical and Experimental Pathology, Salt Lake City, UT, USA; ²Department of Pathology, University of Utah School of Medicine, Salt Lake City, UT, USA

Introduction and Objectives: Antiarrhythmic drugs are commonly prescribed in the USA and are monitored by liquid and gas chromatographic methods. Runtimes, interferences, and extractions for liquid chromatographic methods have been improved using ultra high pressure liquid chromatography-tandem mass spectrometry. A rapid and simple procedure for monitoring amiodarone and metabolite, flecainide, mexiletine, propafenone and sotalol was developed using a Waters Acquity system.

Method: Antiarrhythmic drug concentrations in serum and plasma were determined by ultra pressure high performance chromatography with tandem mass spectrometry detection (Waters Acquity UPLC TQD, [UPLC-MS/MS]). The instrument is operated with an ESI interface, in multiple reaction monitoring (MRM), and positive ion mode. The resolution of both quadrupoles was maintained at unit mass resolution with a peak width at half height of 0.7 amu. The data analysis is performed using the Waters Quanlynxs software. Serum samples were thawed at room temperature and a 20- μ L aliquot was placed in a tube. Then 500 μ L of precipitating reagent (acetonitrile-methanol [50:50, volume: volume]) containing the internal standard (0.1 mg/L loxapine) was added to each tube. The samples were then vortexed and centrifuged. The supernatant was transferred to an autosampler vial and 2 μ L was injected into the UPLC-MS/MS. Utilizing a Waters Acquity UPLC HSS T3 1.8 μ m, 2.1 x 50mm column at 25°C the analytes were separated using a timed, linear gradient of acetonitrile and water, each having 0.1% formic acid added. The column is eluted into a Waters Acquity UPLC TQD, operating in a positive mode to detect loxapine at transition 328>84, amiodarone at 646>58, desmethylamiodarone at 618>547, sotalol at 273>255.1, flecainide at 415.1>398.1, mexiletine at 180>58, and propafenone at 342.2>98. Secondary transitions for each analyte are also monitored for loxapine at transition 328>297.1, amiodarone at 646>73 desmethylamiodarone at 618>72, sotalol at 273>213.1, flecainide at 415.1>301, mexiletine at 180>105, and propafenone at 342.2>72. The run-time is 1.8 minutes per injection with baseline resolved chromatographic separation.

Results: The analytical measurement range was 0.3 to 6.0 mg/L for amiodarone and metabolite desmethylamiodarone and sotalol. The analytical measurement range for flecainide, mexiletine and propafenone was 0.1 to 3.0 mg/L. Intra-assay imprecision (CV) was less than 10% and inter-assay CV was less than 8% at three different concentrations.

Conclusions: By utilizing a UPLC-MS/MS method we combined five analytical assays into one, yielding a 70% time-savings on set-up, significantly shortened analytical run-time reducing all turn-around times for analysis and eliminated interference issues resulting in fewer injections and increased column lifetime.

Key Words: Tandem Mass Spectrometry, Anti-Arrhythmic, Therapeutic Drug Monitoring

HIV/AIDS Risk Questionnaire Accuracy to Detect Drug Use in Prison

Heráclito Barbosa Carvalho*¹, Maria Claudia de Mattos Fabiani¹, Ilham El Maerawi², Gabriel Andreuccetti¹, Fernanda Justo Descio¹, Vilma Leyton¹

¹Faculty of Medicine, University of Sao Paulo, SP- Brazil; ²Health Secretariate of Sao Vicente City - STD/AIDS Program- SP Brazil

Introduction: In this study, we compared the performance of a questionnaire for assessing drug use in a prison population to the results from toxicological analysis of urine.

Methods: A cross-sectional observational study was conducted in September 2007, in a population of male inmates incarcerated in the state of Sao Paulo. The prisoners were interviewed and also underwent enzyme multiplied immunoassay testing (EMIT) for cannabinoids and cocaine metabolites. Two questions were asked of the prisoners; one about drug use in general, and a second as a more specific question to identify the drug consumption pattern in prison. The ability of the questionnaire to correctly identify drug users in prison was compared with the urine test results for these same individuals. Sensitivity and specificity rates were determined. Interviewer characteristics, total interview time, age of respondents, time in jail, relationship between the offense and drug use, and total penalty time were considered factors with the potential to affect the results.

Results: 337 prisoners completed the questionnaire and provided urine samples for the study. The subjects had a mean age of 30.4 years, having spent an average time of 1 year and 4.7 months, and average sentence of 10.1 years. The majority of subjects did not commit crimes related to drugs (73.3%). The prevalence based on urine toxicological analysis was 61.4% for marijuana and 7.7% for cocaine. When the answers to the questions were combined with the toxicological results, the assessment for drug consumption was more sensitive. Of the 260 respondents identified by the questionnaire as a drug user in prison, 191 had positive toxicological results and 69 negative results. Of the 76 respondents identified as non-drug users in prison via questionnaire, 21 had positive toxicological results and 55 negative (sensitivity=90.1% and specificity =44.1%). The prevalence of drug use in prison, taking into account only the interview responses was 77.1% and 8.6%, for marijuana and cocaine, respectively. Prisoners who have committed crimes related to drugs performed better in answering questions related to cocaine use ($\chi^2_{GL1}=6.41$, $p=0.011$). The younger prisoners consumed more marijuana in prison (80.6%, $\chi^2_{GL4}=31.95$, $p=0.000$) than their older counterparts. Repeat offenders (11.4%, $\chi^2_{GL1}=5.65$, $p=0.017$) and those who are in prison for longer (13.6%, $\chi^2_{GL2}=6.27$, $p=0.043$) time stood out as those who consume more cocaine. Repeat offenders showed higher frequency of false answers (11.3% x 4.0%, $\chi^2=4.85$, $p=0.028$) while those between 6.33 and 14.62 years in prison (3.4% x 11.0%, $\chi^2=5.06$, $p=0.025$) more often told the truth.

Conclusions: The agreement between the reporting of marijuana and cocaine consumption in prison obtained by questionnaire combined with toxicological screening was adequate for assessment of both general and recent use. Combining responses appeared an effective way to improve the sensitivity of the questionnaire.

Key Words: Toxicology, Urine, Prison

Validated Method for the Determination of Misoprostol Acid in Whole Blood by Ultra Performance Liquid Chromatography – Tandem Mass Spectrometry

Susana Sadler Simões*, Antonio Castañera Ajenjo and Mário João Dias

National Institute of Legal Medicine – South Branch, Rua Manuel Bento de Sousa n°3, 1150-219 Lisbon, Portugal

Objectives: Misoprostol is a synthetic analogue of prostaglandin E₁ approved for the prevention and treatment of non-steroidal anti-inflammatory drug-induced gastric ulcers disease, and frequently used in the obstetrics and gynecology field for cervical ripening at elective termination of early pregnancies and to induce labor. Misoprostol is also used in several countries for medically-unsupervised, self-induced abortions representing serious risks to the women's health. Misoprostol is extensively absorbed, and rapidly metabolized to its pharmacologically active metabolite misoprostol acid, that unlike the parent compound is detectable in plasma. Due to the use of small therapeutic doses of misoprostol, the highest plasma concentration of the active metabolite in human plasma is very low, and therefore it is necessary to develop a highly sensitive analytical method for the quantification of misoprostol acid.

Materials and Methods: To accomplish this, a rapid and sensitive analytical method was developed and fully validated for the determination of misoprostol acid in whole blood samples by ultra performance liquid chromatography – tandem mass spectrometry (UPLC-MS/MS) analysis using negative electrospray ionization and multiple reaction monitoring. The samples were prepared by a simple solid-phase extraction procedure using Oasis® HLB 3cc (60 mg) columns and 1 mL of whole blood. The chromatographic separation was performed with an Acquity UPLC® HSS T3 (50 x 2.1 mm i.d., 1.8 µm) reversed-phase column using a gradient with methanol- ammonia 1% solution and with a run time of 7.0 min. The limit of detection and quantitation was 10 pg/mL and 20 pg/mL, respectively.

Results: The recovery ranged from 89 to 97%, no carryover and no significant matrix effect were observed. The method was linear in the range 10-2000 pg/mL. The intra-assay imprecision ranged from 4.0 to 5.4%. The inter-assay accuracy and imprecision ranged from -2.2 to 7.0% and 6.1 to 7.9%, respectively. Additionally, a temperature stability study of misoprostol acid in blood samples was performed using three different intervals: room temp., 2-8°C and -10°C. Two aliquots were collected for each temperature in twelve different days during a period of 52 days. Misoprostol acid showed to be unstable in all cases with a decrease of the initial concentration (500 pg/mL) of 100% (in 31 days), 77% and 23%, respectively.

Conclusion: This method will be used in controlled misoprostol administration studies and may be a useful analytical procedure for the forensic toxicology field.

Key Words: Misoprostol Acid, UPLC-MS/MS, Whole Blood

Validated Method for Quantitation of Psilocin in Plasma by LC-MS/MS and Study of Stability

Rafaela Martin*, Jennifer Schürenkamp and Helga Köhler
Institute of Legal Medicine, University Hospital, Münster, Germany.

Objectives: Psilocin, the psychoactive component of “magic mushrooms”, is unstable under the influence of light and air and is, therefore, difficult to analyze. The aim of this study was to develop a validated method for psilocin quantitation in plasma. Additionally, psilocin stability in blood was examined under different storage conditions.

Materials and Methods: Ascorbic acid was added after diluting 0.5 mL plasma with phosphate buffer (pH 6) to protect the unstable analyte during the extraction procedure. Solid phase extraction with Oasis MCX columns was performed protected from light. Between different washing steps, the columns were dried with nitrogen. Ascorbic acid was added to the HPLC vial before elution with basic ethyl acetate. The eluate was evaporated to dryness and reconstituted in HPLC mobile phase for LC-MS/MS analysis. Validation was performed according to the criteria of the German GTFCH guidelines. For study of storage conditions, blood was spiked with psilocin and stored at different temperatures over a period of one day to one week.

Results: Calibration curves were linear from 2 – 100 ng of psilocin/mL plasma. No selectivity problems occurred. The limit of detection (LOD) was 0.1 ng/mL and limit of quantification (LOQ) was 0.34 ng/mL. Recovery was $\geq 86\%$ and matrix effects were $\leq 10\%$. Within and between day imprecisions at concentrations of 2, 40 and 100 ng/mL were 1.5 – 4.3 % RSD, bias within $\pm 5\%$. Processed samples were stable in the autosampler for at least 26 hours. Plasma samples were stable after three freeze/thaw cycles. Stability of frozen plasma samples was demonstrated for at least three weeks. Storage of blood samples at room temperature leads to a significant loss of analyte after only one day. Storage at 4°C improved stability, but the best stability was achieved at -20°C.

Conclusions: A sensitive method with clean extracts for psilocin quantitation is presented. Sample preparation and extraction was accomplished in less than two hours. Drying with nitrogen instead of full vacuum is essential for good recovery. Addition of ascorbic acid before and after extraction protects psilocin from oxidation and is important for processed sample stability. Blood samples must be frozen directly after blood collection to prevent degradation of psilocin.

Keywords: Psilocin, LC-MS/MS, Stability

Thiethylperazine Intoxication in a Pregnant Woman in her 12th Week of Pregnancy**Dana Ondrová***¹ and Peter Ondra²¹The Clinics of Gynecology and Obstetrics, Faculty Hospital, Olomouc, Czech Republic; ²The Institute of Forensic Medicine and Medical Law, Faculty Hospital, Olomouc, Czech Republic

Objective: The objective of this paper is to familiarize professionals with the possibility of overdose with thiethylperazine, a typically non-toxic medicament provided to women in the Czech Republic to stop nausea and vomiting during the first three months of gravidity.

Materials and Methods: Isolation of thiethylperazine and thioridazine (internal standard) from patient's serum and urine was accomplished using solid phase extraction on a Strata C 18 columns. Identification was performed on a Thermo Finnigan TraceGC PolarisQ ion trap GC/MS operated in selected ion monitoring (SIM) mode with an RXi-5ms capillary column (15m x 0.25mm x 0.25µm). Quantification of thiethylperazine and thioridazine in serum was based on their relative retention times and ion ratios. Limit of quantification for thiethylperazine 0.005 mg/l was determined as signal-to-noise ratio 10:1.

Results: Thiethylperazine and many of its metabolites, e.g. thiethylperazine-M (ring) and thiethylperazine (sulfone) were identified in urine. Corresponding EI-GC/MS spectra allowed unequivocal identification of these analytes. No other drugs were detected in urine. Toxic concentrations (0.21 mg/l of thiethylperazine) were detected in serum toxicological findings were in correlation with clinical symptoms. They included extrapyramidal manifestations, spasms, opisthotonus, xerostomia, eyeball divergence, unconscious mouth opening connected with face grimacing and pushing the tongue out. These manifestations are described in the medical literature as side effects of thiethylperazine overdose and confirmed during the neurological examination of the patient. Full recovery of the patient took two days. Intoxication by thiethylperazine is very rare, especially in the case of pregnant women, and there was no suspicion of fetus abnormality as a result of the thiethylperazine intoxication. There were no further complications during the pregnancy. The patient gave birth to a healthy babygirl (3450 g and 50 cm) in the 40th week of her pregnancy. The baby, now three years old, has normal psychomotor development.

Conclusion: This work describes a case of overdose with thiethylperazine during the first trimester of pregnancy. Even though no consequences were detected in the development of the fetus, our work highlights the potential danger of treating nausea and vomiting in pregnant women with this pharmaceutical drug, and supports the manufacturers warning to only prescribe thiethylperazine when necessary during pregnancy.

Key Words: Intoxication, Thiethylperazine, Gravidity

Comparison of Opioid Analysis in Whole Blood and Dried Blood Spots

Ricarda Jantos^{*1}, Markus Schumacher² and Gisela Skopp¹

¹Institute of Legal and Traffic Medicine Heidelberg, Germany; ²Federal Highway Research Institute (BASt) Bergisch-Gladbach, Germany

Supported by a grant from the EU-project DRUID (TREN-05-FP6TR-So7.61320-518404).

Objectives: Analysis of dried blood spots (DBS) is an increasingly accepted method in therapeutic drug monitoring whereas its application to forensic samples has not been studied. Contrary to whole blood, DBS sampling is easier, allows storage without additional cooling, decreases the risk of infections with blood-borne viruses and slows degradation of labile analytes. The aim of our study was to investigate whether determination of morphine, hydromorphone, oxycodone, noroxycodone, fentanyl and norfentanyl in DBS is as reliable as in whole blood.

Materials and Methods: DBS (on specimen collection paper Whatman #903) and whole blood analysis was performed using a sample volume of 100 μ L. Analysis was by LC/MS/MS following liquid-liquid extraction except hydromorphone, which was isolated by solid phase extraction. The results were compared using Bland-Altman difference plots.

Results: The number of corresponding specimens (n), the mean concentration ratio (r), the mean difference between the 2 methods (d) and the limits of agreement (l, mean difference \pm 1.96 SD) for each analyte were as follows: Morphine: n=7, r=0.99, d=-2.12 ng/mL, l:-8.31 and 12.53 ng/mL; hydromorphone: n=15, r=0.99, d=0.14 ng/mL, l:-0.90 and 1.17 ng/mL; oxycodone: n=12, r=1.02, d=-1.24 ng/mL, l: -4.46 and 1.98 ng/mL; noroxycodone: n=12, r=1.00, d=0.27 ng/mL, l:-3.26 and 3.80 ng/mL; fentanyl: n=13, r=1.00, d=-0.03 ng/mL, l:-0.20 and 0.14 ng/mL; norfentanyl: n=9, r=0.95, d=-0.01 ng/mL, l:-0.08 and 0.06 ng/mL. Variability of differences between methods was fairly constant across the range of measurement for all analytes. At least 95 % of all differences were within the limits of agreement.

Conclusions: For all analytes, results from DBS exactly matched those from whole blood. The blood/DBS-ratios of all analytes did not differ significantly from 1.00. The Bland-Altman difference plots of the different drugs showed only a single outlier and that outlier was close to the acceptable limit ranges.

Key Words: Dried Blood Spots, Opioids, Whole Blood Comparison

Concentration Patterns of Buprenorphine and Metabolites, With and Without Naloxone, in Human Urine**Heidi J. Carlisle***¹, Rebecka Davis¹, David E. Moody², Chantry Clark¹, and Gwendolyn A. McMillin^{1,3}¹ARUP Laboratories, Inc., SLC, UT, USA; ²Department of Pharmacology and Toxicology, and ³Department of Pathology, University of Utah, SLC, UT, USA

Objectives: Buprenorphine, a partial mu opioid receptor agonist, is used to treat opioid addiction and chronic pain. Naloxone, a mu opioid receptor antagonist, is formulated with buprenorphine in Suboxone[®] (4:1 buprenorphine:naloxone), a sublingual preparation, to discourage alternate routes of administration. Extensive first pass metabolism limits the bioavailability of naloxone. Buprenorphine is also extensively metabolized; as such, both drugs are expected to appear in human urine primarily as metabolites, after administration of Suboxone. The objective of this study was to evaluate concentration patterns of free buprenorphine and its metabolites in clinical urine samples. Follow-up studies also measured free naloxone in selected specimens.

Methods: Unhydrolyzed urine was subjected to solid phase extraction. Free buprenorphine and free norbuprenorphine (both 2-1000 ng/mL) were quantified by UPLC-MS/MS. Buprenorphine and norbuprenorphine glucuronides (5-1000 ng/mL) were semi-quantitatively identified. Free naloxone was quantified (50-2500 ng/mL) by a separate UPLC-MS/MS assay. A database of 2477 results obtained from human urine samples submitted to ARUP Laboratories for non-forensic, targeted buprenorphine analysis between February 2010 and January 2011 was queried to determine the distribution of drug analytes. IRB-approved protocols were employed.

Results: Three major patterns of results were observed: negative for all analytes (n=531, 21.4%), positive for buprenorphine and/or norbuprenorphine and glucuronides (n=1867, 75.4%), and positive for buprenorphine at a concentration >1000 ng/mL, with little or no metabolites present (n=79, 3.2%). A total of 885 samples had parent buprenorphine present. For these, the median was 6.1 ng/mL and 82% were <20 ng/mL. Suspecting that the third population may reflect *ex vivo* addition of a buprenorphine formulation to urine, to mask non-compliance with prescribed therapy (and possible diversion), a subset of 13 samples that contained free buprenorphine >1000 ng/mL (4160 – 39,400 ng/mL) was analyzed and 12 were found to contain very high concentrations of free naloxone (2140 - 9560 ng/mL). The mean buprenorphine:naloxone ratio was 4.02. The very high concentrations of free drugs, and the observation that the ratio of buprenorphine:naloxone approximates the pharmaceutical preparation, suggests that Suboxone was added to the urine *ex vivo*. Another subset of 87 samples containing <20 ng/mL free buprenorphine, with glucuronides present, representative of the common pattern observed in routine positive specimens (second population above), was also tested; all samples were negative for naloxone.

Conclusion: Free buprenorphine concentrations >1000 ng/mL, in the absence of metabolites, could suggest *ex vivo* adulteration. Detection of high naloxone concentration may lend further support to this conclusion, by suggesting that the adulterating agent was Suboxone. Additional studies including naloxone metabolites could help clarify this issue.

Key Words: Suboxone, Adulteration, Pain Management

Toxicological and Clinical Evaluation of Probationers for Marijuana Use in İzmir, Turkey

Serap Annette Akgür¹, Burcu Yüçetürk², Aslı Erdem¹, Demet Havaçeliği¹ and Hakan Coşkunol¹

¹Ege University, Institute on Drug Abuse, Toxicology and Pharmaceutical Sciences, Bornova, 35100, İzmir, Turkey; ²Ege University, School of Medicine, Department of Psychiatry, 35100, İzmir, Turkey

Objectives: Probation has been an accepted alternative to institutional confinement for years and has increasingly been used for serious offenders. This study presents records related to marijuana use of the probationers who were diverted to Ege University, Institute on Drug Abuse, Toxicology and Pharmaceutical Sciences for a 12-month period (during 2010). An evaluation of the toxicological data, demographic characteristics, area where the probationer grew up (urban/rural), substance use characteristics, physical and mental history, and social and judicial/clinical status was performed.

Materials and Methods

This is a descriptive, cross-sectional study that evaluates probationers' marijuana use/abuse. All subjects were referred to Ege University Institute on Drug Abuse, Toxicology and Pharmaceutical Sciences for a 12-month period (n = 315). A trained clinical psychiatrist interviewed the subjects to assess substance use with the Turkish version of the Structured Clinical Interview SCID for DSM-IV. Urine specimens were analyzed by CEDIA and GC-MS for cannabinoids and other legal/illegal abused drugs.

Results

All subjects were male and 18-82 years of age. Individual toxicological/clinical outcomes were evaluated with marital status, area where the probationer grew up, economic level and educational status. Among 315 subjects, 210 (65%) were tested by random drug screen on the same day they applied to our clinic. The remaining 105 people (35%) were screened for drugs at a scheduled appointment. 175 people (56%) had negative toxicological results and were not accepted into the addiction program. Instead, this group was monitored by the psychiatrist and psychologist 3-4 times during 6-7 weeks. 140 people (43%) gave positive toxicological results and were accepted in the addiction treatment program.

The addiction program had two treatment types, which included individual (69%) and group therapy (31%). Fifty percent of the subjects completed the group therapy program successfully according to the toxicological and clinical assessment and 34% of the subjects were unsuccessful. The rest (16%) of the group was not evaluated since they did not attend the program and their appointments. For the individual therapy program, 53% of the subjects completed the therapy program successfully according to the toxicological and clinical assessment and 33% of the subjects were unsuccessful. The rest (14%) of the group was not evaluated since they did not attend the program and their appointments.

Conclusions: Since 2006, the drug treatment court offers drug offenders a therapeutic alternative to the traditional adjudication process in Turkey. Therefore, the data in this study will be helpful in probation treatment programs to promote more effective treatment and toxicological approaches.

Key words: Marijuana, Probation, Toxicological Analysis

Development of a Colorimetric Assay Kit for the Measurement of Acetaminophen with Enhanced Precision and Assay Range on the Fully Automated RX Series Analysers

Paul McGivern, **Richard Bell***, John Campbell, and S. Peter Fitzgerald
Randox Laboratories Ltd., Crumlin, United Kingdom

Objective: Acetaminophen is a commonly used analgesic drug, which usually has no adverse effects. However, in some cases of long-term treatment with acetaminophen, hepatotoxicity and nephrotoxicity have been reported where chronic excessive use has been a factor. In cases of overdose, it can cause severe hepatic damage leading to hepatic failure if left untreated. Early diagnosis of acetaminophen-induced hepatotoxicity is important since initiation of therapy within 8 hours of ingestion lessens the potential for hepatic injury and decreases the mortality rate. We report the development of a colorimetric assay kit with enhanced precision and assay range for the measurement of acetaminophen in human serum applied to the fully automated RX series analysers. This provides accuracy and precision across an enhanced detection window, which is of value for the monitoring of this drug in test settings.

Methods: The assay is colorimetric and uses two liquid reagents. Following the enzymatic cleavage of acetaminophen, p-aminophenol and acetate are produced. The p-aminophenol is subsequently converted to an indophenol and the reaction is measured colorimetrically at 600 nm. The assay was applied to the RX series analysers, which include dedicated software for data management. Concentrations were calculated from two-point calibration. On-board and calibration stabilities were tested by storing the reagents uncapped on the RX series analysers for a period of 28 days. Within-run and total precision were assessed by testing serum samples at defined medical decision levels, 2 replicates twice a day for 20 days. Correlation studies were conducted with 50 serum samples.

Results: Evaluation of the performance parameters showed an assay sensitivity of 2.26 mg/L for an assay range of 2.26 – 503.5 mg/L. The within-run precision and total precision expressed as %CV was ≤ 5 for three different concentration levels. The liquid assay reagents presented an on-board stability of 7 days at $\sim 8^{\circ}\text{C}$ and a calibration frequency of 3 days. Correlation with other commercially available assay generated the following linear regression equation $Y = 1.03x - 2.83$, $r = 1.00$.

Conclusions: The data shows this colorimetric assay kit exhibits high level of precision across an extended analytical measuring range without compromising good agreement with current existing methodologies in terms of acetaminophen measurement in patient samples. The advantage of an increased analytical measuring range represents an improvement for the accurate and reliable monitoring of acetaminophen levels and accurate determination of drug toxicity.

Key Words: Acetaminophen, Colorimetric Assay Kit, RX Series

Acute Poisoning by Slimming Capsules "Best Life": Clinical and Analytical Data

C. Jamey*¹, A. Tracqui¹, C. Tournoud², P. Bilbault³, F. Flesch², and B. Ludes¹

¹Laboratoire de Toxicologie, Institut de Médecine Légale, Strasbourg, France; ²Centre Antipoison, CHU, Strasbourg, France;

³Service de réanimation médicale, CHU, Strasbourg, France

Objectives: A 24-yr old woman was admitted to the Emergency Unit for tachycardia, dizziness, palpitations and abdominal pain. Questioning of the patient revealed a self-administration of slimming capsules marketed under the trade name "Best Life". This product mainly contains sibutramine, used in the treatment of obesity, and phenolphthalein known for its laxative properties. A blood sample was taken for toxicological analysis. In this context, a novel method was developed for determination of sibutramine, together with its metabolites M1 (N-monodesmethyl) and M2 (N-didesmethyl) and phenolphthalein using ultra-performance liquid chromatography/tandem mass spectrometry (UPLC-MS/MS).

Methods: In a 1.5 mL Eppendorf tube, 200 μ L of sample, 2 ng prazepam as internal standard (IS), 200 μ L of phosphate buffer pH 5.5, and 800 μ L of dichloromethane/n-heptane/2-propanol (25:65:10, v/v) were added. After stirring (vortexing, 30 s), centrifugation (10500 g, 5 min) and evaporation, the dry extract was reconstituted in 50 μ L of acetonitrile (ACN)/ formic acid (HCOOH) 0.1% (50:50, v/v) and 10 μ L were injected onto the column. Separation was achieved on an Acquity UPLCTM (Waters) C18 1.7 μ m column (100 x 2.1 mm, i.d.), using a gradient of ACN/0.1 % HCOOH at a flow rate of 0.5 mL/min. Analysis was completed in 5.5 min. Detection was performed by a Quattro PremierTM XE (Waters Micromass) tandem mass spectrometer using multiple reaction monitoring (MRM) mode with the following transitions: 280.1-124.7, -138.7, and -152.8 (sibutramine); 266.1-124.7, -138.7, and -152.8 (M1); 252.0- 124.7, -138.7, and -152.8 (M2); 319.0-224.9. -140.8, and -114.7 (phenolphthalein); 325.0-270.9 (IS). According to the literature, phenolphthalein exhibits a significant glucuronidation, thus a preliminary step of hydrolysis with beta-glucuronidase (2 h at 40°C) was also performed.

Results: Under these UPLC-MS/MS conditions, the average retention times were: 2.51 min (sibutramine), 2.24 min (M1), 2.08 min (M2), 1.72 min (phenolphthalein) and 3.70 min (IS). The limits of detection (LOD) and quantification (LOQ) were 0.01 ng/mL and 0.02 ng/mL for sibutramine and both metabolites, and 0.2 ng/mL and 0.5 ng/mL for phenolphthalein, respectively. Recoveries were found > 80 % for sibutramine and metabolites and > 30 % for phenolphthalein. Linearity ($r^2 > 0.99$; LOQ - 20 ng/mL for sibutramine and its metabolites; LOQ - 10000 ng/mL for phenolphthalein), precision (CV < 15 %) and accuracy (94% to 108%) were satisfactory. The patient blood analysis revealed the presence of sibutramine at 0.40 ng/mL, M1 at 0.55 ng/mL, M2 at 1.89 ng/mL, free phenolphthalein at 1.2 ng/mL and combined phenolphthalein at 166 ng/mL, confirming the extensive glucuronidation of this compound.

Conclusion: The UPLC-MS/MS analysis allowed the identification of a combined intake of sibutramine and phenolphthalein. To our knowledge this is the first case of poisoning by slimming capsules "Best Life" reported in the toxicological literature.

Keywords: Sibutramine, Phenolphthalein, UPLC-MS/MS

Analysis of Oral Anti-Diabetic Drugs and their Metabolites in Blood and Urine by Thin-Layer Chromatography

Mareta Mukharbekovna Ibragimova*¹, Baltabay Allaniyazovich Eshmuratov¹, Ilhom Gafurovich Akhmedjanov² and Latif Tulyaganovich Ikramov³

¹The Forensic-Medical Bureau of Tashkent City, Tashkent, Uzbekistan; ²The Forensic-Medical Bureau of the Ministry of Health of the Republic of Uzbekistan, Tashkent, Uzbekistan; ³Pharmaceutical Institute, Tashkent, Uzbekistan.

Introduction: Oral anti-diabetic drugs constitute three chemical classes: derivative sulfonylureas (glibenclamide, gliclazide, glipizide, glimepiride and glicvidone), biguanides (metformin) and thiazolidinediones (rosiglitazone). Recently, abuse of these drugs have become frequent for suicidal purposes. Blood and urine from anti-diabetic drug overdose victims most often come to the forensic-chemical laboratories from resuscitation departments and require rapid analysis.

Aims: The aim of this research was to develop a thin-layer chromatography method (TLC) to screen for these anti-diabetic drugs and their metabolites with the TOXI-LAB system.

Materials and Methods: Whole blood and urine specimens from patients with diabetes (45 cases), accidental overdose cases not resulting in death (7 cases), postmortem blood and urine (3 cases) and whole blood and urine of animals (rabbits of both sexes) after oral administration (30-300 mg/kg) of anti-diabetics were investigated. Metformin and rosiglitazone were extracted with TOXI-A tubes, while the sulfonylurea derivatives were extracted with TOXI-B tubes. Extraction, chromatography and detection were performed according to the recommended TOXI-LAB procedures. These drugs were subsequently quantified by high-performance liquid chromatography (HPLC). Chromatographic conditions included a XP-18, 4.6 x 250 mm, 5µm column, spectrophotometric detection at 190-600 nm, an injection volume of 20 µL, and oven temperature of 40°C. Mobile phase and detection wavelength were different for each drug. The HPLC detection limits of all analytes in pure solutions were 0.001-0.05 µg/mL. For blank matrix, we used the blood and urine of healthy volunteers.

Results: Sulfonylureas, metformin, rosiglitazone and their metabolites were detected with the Toxi-Lab system. Color characteristics of each drug and their metabolites along with the Rf values were established through all stages of analysis. Limits of detection of the sulfonylurea derivatives with TOXI-LAB were 1.5 µg/mL in whole blood and 1.0 µg/mL in urine, and for metformin and rosiglitazone 1.0 µg/mL in whole blood and 0.5 µg/mL in urine. Additionally, PHOTO-GRAMS were created for the targeted analyte of each drug.

Conclusions: TOXI-LAB's TLC method was useful for screening for oral anti-diabetic drugs and their metabolites in whole blood and urine.

Key Words: Anti-Diabetic Drugs, Overdose, TOXI-LAB

Analysis of Markers for Nicotine Exposure in Urine Specimens

Carrie J. Haglock*¹, David E. Moody² and Gwendolyn A. McMillin^{1,3}

¹ARUP Laboratories, Salt Lake City, UT, USA; ²Department of Pharmacology and Toxicology, University of Utah, Salt Lake City, UT, USA; ³ARUP Institute for Clinical and Experimental Pathology, and Department of Pathology, University of Utah, Salt Lake City, UT, USA

Objectives: Urine testing for nicotine metabolites is commonly performed for many purposes, such as proof of smoking cessation, life insurance, and suitability for surgical procedures. Criteria have been proposed by Moyer et al. (Clin Chem 48:1460-1471, 2002) to discriminate between abstinence, environmental exposure, and active use. The objective of this study was to evaluate the relationship between nicotine and its metabolites using results generated by our testing program over 1 year (September 2009-2010), and compare them to the Moyer criteria.

Materials and Methods: Human urine samples were prepared by solid phase extraction. Analysis was performed by LC-MS/MS for nicotine (NIC), cotinine (COT), *trans*-3-OH-cotinine (3 OH COT), nornicotine (NRNC) and anabasine (ANAB) with respective lower limits of quantitation of 2, 5, 50, 2 and 3 ng/mL. Results were deidentified by protocols approved by the University of Utah IRB. Of 8354 samples analyzed, 3370 (40.3%) were positive for one or more analytes; leaving the majority of the samples (59.7%) with a negative result.

Results:

In Table 1, the correlation of one positive analyte (column) to the remaining analytes (row) is demonstrated. For example, when NIC was positive (≥ 2 ng/mL), COT, 3 OH COT, NRNC and ANAB were positive in 79.6, 67.7, 88.1 and 37.8 % of samples.

Table 1		Percent of samples in which analyte is also positive				
		NIC \geq	COT \geq	3 OH COT \geq	NRNC \geq	ANAB \geq
When Positive	NIC ≥ 2		79.60%	67.70%	88.10%	37.80%
	COT ≥ 5	94.00%		80.10%	99.60%	44.60%
	3 OH COT ≥ 50	99.80%	100%		99.80%	55.70%
	NRNC ≥ 2	90.40%	86.50%	69.50%		38.80%
	ANAB ≥ 3	99.90%	99.70%	99.80%	99.90%	

Table 2 shows the percent of analytes that agreed with the Moyer criteria for active use.

Table 2		Percent of samples in which analyte is \geq cutoff				
		NIC \geq	COT \geq	3 OH COT \geq	NRNC \geq	ANAB \geq
Above Active User Cutoff	NIC ≥ 1000		94.80%	0.00%	100.00%	66.20%
	COT ≥ 1000	37.40%		0.00%	99.80%	63.40%
	3 OH COT ≥ 3000	0.00%	0.00%		0.00%	0.00%
	NRNC ≥ 30	29.80%	69.40%	0.00%		21.70%
	ANAB ≥ 10	80.60%	95.10%	0.00%	98.00%	

These data suggest that NIC, COT and NRNC are more sensitive predictors of nicotine use than 3-OH COT, and that the proposed criteria for defining active use should be reconsidered for 3 OH COT (too high) and NRNC (too low).

Key Words: Nicotine Metabolites, Cotinine, Tobacco

In Vivo Levamisole Metabolism in Humans

Elisabetta Bertol*¹, Francesco Mari¹, Viola Bartolini¹, Maria Grazia Di Milia¹, Lucia Politi¹ and Steven B. Karch²

¹Division of Forensic Toxicology, University of Florence, Italy; ²Consultant Pathologist/Toxicologist, Berkeley, CA

Objectives: The ability of equines to metabolize levamisole to aminorex was first recognized in 2010. However, the metabolic fate of levamisole in humans is unknown. Nevertheless, as aminorex is amphetamine-like and hallucinogenic, it may be used as an adulterant to increase the effects of cocaine, with agranulocytosis and pulmonary hypertension risk. The aim of the present study is to prove, for the first time, that not only equine, but also human metabolism of levamisole results in aminorex formation confirming human *in vivo* conversion of levamisole to aminorex.

Materials and Methods: Urine samples were collected from 8 healthy volunteers (4 males weighing 70 - 80 Kg, 4 females weighing 55 - 65 Kg, all 35 to 45 years old). Urine specimens were collected immediately before, and 3 and 6 hours after the administration of 47 mg and 58 mg of levamisole by the oral route (47 mg for female and 58 mg for male). Levamisole and aminorex were extracted from urine samples (using mephentermine as internal standard) with diethylether after stabilization at pH 9. Both reduced volume samples and trimethylsilyl derivatives, obtained by adding N-Methyl-N-(trimethylsilyl) trifluoroacetamide, were injected in a GC-MS apparatus equipped with a phenylmethylsilicone 5% capillary column (injector 300°C oven T° programmed-80°C for 1 min, increased to 300°C at 20°C/min for 3 minutes). Identification was performed monitoring 5 ions for each analyte.

Results: Acceptable linear regression was obtained for both calibration curves (levamisole: $y = 0.134x + 0.034$, $R^2 = 0.997$; aminorex: $y = 0.202x + 0.125$; $R^2 = 0.995$). Inter-day imprecision and inaccuracy were always better than 10% for levamisole and 12% for aminorex. The LLOQ was 0.15 ng/ml for both analytes and the LOD was set at the same concentration.

Our results demonstrate in all urine specimens (1-8) sampled at 3 and 6 hours after administration the presence of levamisole at a mean concentration (ng/ml) of 40.63 (min 30.05 - max 53.22, SD 8.62) and 20.63 (min 12.45 - max 28.34, SD 6.56), respectively. Aminorex was found at a mean concentration (ng/ml) of 30.63 (min 22.52- max 38.12, SD 5.48) and 28.32 (min 20.08- max 43.6, SD 7.95), respectively.

Conclusions: In conclusion the proof of levamisole metabolic conversion to aminorex is of importance for public health since, according to seizure data, nearly 70% of the US cocaine and about 40% of EU cocaine is adulterated with levamisole. Conversion rate is not currently known, but if the rate is significant, cocaine abusers are at risk of developing pulmonary hypertension.

Key Words: Cocaine Adulteration, Levamisole, Aminorex, *In Vivo*, Human Metabolism

Toxicokinetics of Isopropanol, Acetone, Methylethylketone and Toluene Following an Overdose

Helene Eysseric*^{1,2}, Mireille Bartoli¹, Nathalie Allibe², Jerome Hanna³, Françoise Stanke

¹UM Pharmacologie-Toxicologie, DBTP, CHU Grenoble, France; ²Laboratoire Médecine Légale, UFR Médecine Grenoble, France; ³Réanimation Polyvalente Chirurgicale, CHU Grenoble, France

Introduction: A comatose 74-year-old man with no medical history was hospitalized for intoxication after ingestion of a solvent. At admission in the intensive-care unit, the patient presented with a Glasgow Coma Score of 3/15, low blood pressure (70/50 mmHg) and pupillary constriction. Biological specimens were submitted to the laboratory of toxicology for testing.

Clinical Case: One hour after his admission, the patient was found in severe shock with vasodilatation, cardiac complications, very low blood pressure (40/20 mmHg) and was immediately administered 2 mg adrenaline and 11 mg per hour of noradrenaline. Seizures were treated by diazepam, midazolam and fosphenytoin. An examination by endoscopy found esophagitis and gastritis without risk of perforating, and was treated with omeprazole. Results of clinical testing showed metabolic acidosis and hyperlactatemia and therefore the patient was hemodialyzed for 12 hours. Extubation occurred 48 hours after admission. After suspension of drugs for sedation, the patient became conscious during the second day.

Materials and Methods: The initial screening applied to the blood and the urine involved measuring ethanol, methanol, isopropanol, acetone and ethylene glycol by gas chromatography coupled with a flame ionization detector (GC/FID, Agilent) and GHB by GC mass spectrometry (GC/MS, Agilent). Positive findings were confirmed by GC/MS and screening of the blood by liquid chromatography coupled with diode-array detection (LC/DAD, Shimadzu). Blood samples were collected at 2, 24, 48 and 72 hours and two urine specimens were collected at 2 and 72 hours after ingestion.

Results: Initial screening detected isopropanol and its metabolite, acetone. The additional analysis, identified methylethylketone and toluene.

Analytical results are seen in Table 1:

Concentrations in plasma (Pl) or in urine (Ur) (mg/L)	t = 2h		t= 24 h	t= 48 h	t= 72 h		Reference toxic blood level [www.tiaft.org Le13/04/2011]
	Pl	Ur	Pl	Pl	Pl	Ur	
Isopropanol	1360	400	< 25	< 25	< 25	< 25	200
Acetone	640	240	730	350	100	110	200
Methylethylketone	493	186	246	51	19	19	500
Toluene	8	<2	4	2	<2	<2	Not described

Conclusion: The laboratory identified and quantified solvents responsible for the severe intoxication of this patient. This allowed clinicians to follow the elimination of isopropanol and its metabolite acetone, of methylethylketone and toluene and to check the absence of relargagé. Finally the etiologic assessment was not able to distinguish between a voluntary and involuntary poisoning in connection with dementia.

Key Words: Isopropanol, Methylethylketone, Solvents Intoxication

Fatal and Non Fatal Methadone Related Intoxications in the Region of Thessaloniki (Northern Greece)

Orthodoxia Mastrogianni¹, Zagelidou Heleni¹, Nikolaos Vasiliadis², Georgios Theodoridis³, Fotios Chatzinikolaou², Theodora Tafarli¹, Panagiotis Mylonakis¹, Konstantina Spagou², Georgios Antonoglou² and **Nikolaos Raikos**^{*,2}

¹Laboratory of Forensic Service of Ministry of Justice of Thessaloniki, Greece; ²Laboratory of Forensic Medicine and Toxicology, Medical School, Aristotle University, Thessaloniki, Greece; ³Laboratory of Analytical Chemistry, Department of Chemistry, Aristotle University, Thessaloniki, Greece

Objectives: Methadone is a long acting opioid and is used in methadone maintenance programs to treat drug misusers as a substitute for heroin. About 1200 opioid dependant persons participate in Thessalonikis' substitution treatment programmes (Northern Greece). It seems that opioid substitution treatment diminishes the risk of death of a heroin user. The most serious symptoms of methadone overdose consist of respiratory depression, circulatory collapse, cardiac arrest and coma. Prior to 2008 methadone was not detected in any fatal or non-fatal intoxication in the wider region of Thessaloniki. The aim of the current study was to demonstrate the illicit diversion of methadone in the region of Thessaloniki, by presenting the intoxications related to methadone use from January 2008 through March 2011.

Materials and Methods: Biological samples from suspected lethal and non lethal drug related intoxications were sent for toxicological analysis. Blood and urine samples were screened for the presence of drugs by GC-MS, EMIT and FPIA. A gas chromatograph Agilent Technologies 7890A with a MS 5975C inrtXL, EI/CI MSD with Triple-Axis detector was used for the determination of methadone after liquid-liquid extraction.

Results: Approximately 80 to 90 drug-induced fatalities annually occurred in the wider region of Thessaloniki.

Sex, age	M 27	M 47	M 27	M 43	M 38	M 47	M 53	M 26	F 82	M 43	M 27	M 36	M 30	F 2.5	M 30
Year	2008	2008	2009	2009	2009	2010	2010	2010	2010	2010	2010	2010	2010	2011	2011
Sample	U(f)	U(f)	U(f)	U(f)	B (f)	U(f)	U(f)	U(c)	B(f)	U(f)	U(c)	B(f)	U(c)	U(c)	B(f)
Concentration (ng/ml)					474				45			237			100
Other drugs detected	mor benz	mor benz	mor benz THC	mor	THC mor	THC mor benz TCA	mor	-	-	mor	benz	benz	benz	-	benz
History of drug abuse	+	+	+	+	+	+	+	+	-	+	+	-	+	-	+

Abbreviations: M: male, F: female, U: urine, B: blood, f: forensic, c: clinical, mor: morphine, benz: benzodiazepines, THC: cannabinoids, TCA: tricyclic antidepressants.

Methadone was detected in 2 drug-induced deaths in 2008 and in another 3 cases in 2009. All these 5 drug-induced fatalities were related to polydrug use and the deceased were male drug abusers. During 2010, four cases were multiple drug use whilst in one case the death was attributed to methadone intoxication. In February of 2011 another fatality attributed to methadone intoxication in combination with benzodiazepines occurred. Also, four non-lethal intoxications happened from November 2010 through March 2011. Prior to October 2010 methadone was never detected in biological samples sent to our laboratory for toxicological analysis from emergency and intensive care units of the local hospitals. Of the four non-fatal cases, three were male opioid users and the fourth was a female child two and half years old.

Conclusion: This study shows an increasing trend in prevalence of methadone use among drug users in the region of Thessaloniki and that most of the presented drug-induced cases were related to multiple drug use. The greater illicit availability of methadone seems to lead to the emergence of cases of uncontrolled methadone intake by inexperienced users for analgesic purposes and accidental intoxications.

Keywords: Methadone, Intoxications, Northern Greece

Determination of Clenbuterol in Human Plasma and Urine by Liquid Chromatography Tandem Mass Spectrometry: Diagnosis of an Overdose in a Bodybuilder

Jose Luiz da Costa*^{1,2}; Rafael Lanaro²; Fabio Bucarechi² and Eduardo Mello De Capitani²

¹Forensic Toxicology and Chemistry Laboratory, Criminalistic Institute of Sao Paulo, SP, Brazil; ²Campinas Poison Control Center, Faculty of Medical Sciences, State University of Campinas, SP, Brazil

Introduction: Clenbuterol is a potent, long-acting β_2 -adrenergic agonist, widely used in patients with asthma in the 1980's. It was banned for human use in many countries because of its serious side effects. Although it has only been authorized for veterinary use in Brazil, some bodybuilders have been taking clenbuterol due to its sympathomimetic, lipolytic, and anabolic effects.

Objectives: This work describes a simple method based on liquid-liquid extraction (LLE) and liquid chromatography–tandem mass spectrometry (LC–MS/MS), used to confirm an acute intentional poisoning by clenbuterol in a young bodybuilder.

Materials and Methods: Exactly 200 μ L of plasma or urine were transferred into a 2 mL conical polypropylene tube containing 50 μ L of salbutamol solution (50 ng/mL in methanol, used as internal standard). In addition, 50 μ L of 1 M NaOH and 1 mL of methyl tert-butyl ether (MTBE) were added. After vortexing for 60 s, each sample was centrifuged at 12,500 rpm for 5 min, the supernatant was evaporated to dryness under nitrogen flow (at room temperature), reconstituted with 500 μ L of mobile phase and filtered under pressure through a 0.45 μ m membrane directly into the injection vial. Twenty microliters were injected onto the LC-MS/MS composed by a Prominence (Shimadzu) LC system coupled to a 4000Qtrap mass spectrometer (Applied Biosystems/MDS Sciex). Chromatographic separation was performed on a Synergi Fusion-RP C18 column (50.0 x 2.0 mm, 2.5 μ m) and isocratic elution performed with acetonitrile:water (60:40 v/v) with 0.1% formic acid, flow rate 0.5 mL/min and total run time of 3.5 min. The mass spectrometer was set to positive electrospray ionization and MRM mode with the following transitions: 277 \rightarrow 132, quantitation; 277 \rightarrow 203, qualification (salbutamol: 240 \rightarrow 148). For method validation, blank plasma and urine samples were spiked with clenbuterol standard solution, and processed according to the sample preparation procedure described above.

Results: The method was linear from 0.05 to 10 ng/mL for plasma and from 0.5 to 100 ng/mL for urine ($r^2 > 0.98$). Recovery was greater than 85% for both matrices, accuracy 87–104% and imprecision less than 8.3% coefficient of variation. Limit of detection (S/N > 3.0) was 0.01 ng/mL for both matrices.

Case Report: A previously healthy 18-year-old male ingested 40 tablets of clenbuterol hydrochloride (1 tablet = 20 μ g; total dose = 0.8 mg) in a suicide attempt. He was admitted at the local ED with tremors, vomiting, headache, tachycardia, chest pain, low blood pressure, hypokalemia (2.3 mEq/L; RV = 3.5-4.5) and ST segment depression in anterior wall leads. Plasma clenbuterol concentrations were 1.4, 0.49, 0.17 and 0.15 ng/mL in 9, 21, 48 and 71 hours after ingestion, respectively. Urine concentrations were 84.7, 20.6, 1.3 and 0.6 ng/mL in 9, 21, 48 and 71 hours after ingestion, respectively. The patient was referred to the university hospital and treated with a single dose of 20 mg oral propranolol (20 h post-ingestion), with significant improvement 30 min later; no chest pain, blood pressure from 120/40 to 120/80 mmHg, pulse rate from 115 to 86 bpm.

Conclusion: Clenbuterol concentrations in different biological samples can be rapidly assessed with the present method. The method was successfully applied to monitor a suicide attempt with clenbuterol.

Key Words: Clenbuterol, Plasma, Urine, LC-MS/MS

Persistent Biomarkers for Verification of Exposure to Organophosphate and Organophosphothioate Pesticides – A Case Study

M.J. van der Schans, D. Noort, A.G. Hulst and A. Fidder
TNO – CBRN Protection, Rijswijk, The Netherlands

Objectives: Current methods used for assessment of pesticide exposure include the determination of cholinesterase activity, analysis of intact pesticides and analysis of urinary metabolites. Since these biomarkers are mostly short-lived, there is a need for additional and more persistent biomarkers.

Materials and Methods: The methodology presented herein is based on the adduct formation of pesticides and their reactive metabolites with proteins such as butyrylcholinesterase (BuChE) and albumin. In this paper these new methods are illustrated through the analysis of plasma samples from intoxicated patients taken 33-49 days after exposure to chlorpyrifos and diazinon. Using the fluoride reactivation method, the phosphoryl moiety was released from the protein, resulting in O,O-diethyl phosphorofluorothioate and its oxon analog, and then analyzed with GC-MS. An alternative approach involved the isolation of the modified proteins, followed by enzymatic digestion and subsequent analysis of the modified peptide fragment with LC-MS.

Results: Analysis of pepsin-digested BuChE revealed that only the aged adduct of the oxon-analog of the pesticides was detected as the FGES*AGAAS peptide, with S* representing the serine residue modified with an (aged) phosphoric acid ester moiety. Upon isolation and digestion of albumin with pronase, tyrosine modified with a O,O-diethylphosphorothiono moiety could be detected, stemming from the thioate form of the pesticides.

Conclusion: In conclusion, for the verification of exposure to chlorpyrifos and diazinon, several independent methodologies could be applied that all document the same exposure, either resulting from adduct formation by the parent thioate form of the pesticide or resulting from the reactive oxon metabolite of the pesticide, which is important, because forensic standards require that exposures to xenobiotics are verified by at least two different analytical methods.

Key Words: Pesticides, Organophosphates, Chlorpyrifos, Diazinon, Diagnosis, LC-MS

Case Report of a Clozapine Intoxication of a 13-Month-Old Girl: Quantification of Clozapine and Its Main Metabolites in Serum and Urine Samples Over 11 Days

Ariane Wohlfarth*, Nicole Töpfner, Maren Hermanns-Clausen and Volker Auwärter
Institute of Legal Medicine, University Medical Center, Albertstr. 9, 79104 Freiburg, Germany

Introduction: This case report describes a possible accidental clozapine intoxication of a 13-month-old girl who was taken to the hospital after showing respiratory insufficiency, tachycardia and sopor alternating with agitation. An extensive diagnostic investigation was initiated including a toxicological immunoassay screening. All results remained negative while the coma of unknown origin persisted. Finally, LC-MS/MS analysis was performed and revealed the presence of clozapine and its metabolites. We analyzed plasma and urine samples taken at the probable day of clozapine ingestion and after 1, 3, 5 and 11 days.

Methods and Materials: A LC-MS/MS method was developed and validated for plasma and urine for the determination of the atypic neuroleptic clozapine and its two main metabolites norclozapine and clozapine-N-oxide. Briefly, after addition of d4-clozapine, a fast single-step liquid-liquid extraction under alkaline conditions (sodium carbonate) with ethyl acetate as organic solvent followed. The analytes were chromatographically separated on a Synergi Polar RP column using gradient elution with ammonium formate and methanol. Data acquisition was performed on an Applied Biosystems QTrap 2000 tandem mass spectrometer in MRM mode with positive electrospray ionization. The validation included the determination of the limits of quantification, assessment of matrix effects and the determination of extraction efficiencies as well as data accuracy. Calibration curves were measured from 1 ng/mL (serum) or 2 ng/mL (urine) up to 2000 ng/mL. Any specimens with concentrations >upper limit of quantification were diluted (1:5) prior to analysis. An extra calibration with 1:5 diluted urine samples served for quantification.

Results: The maximum serum clozapine concentration was observed on the probable day of ingestion (736 ng/mL). It decreased to 185 ng/mL on the next day and to 18 ng/mL by the third day. Visible, but not quantifiable clozapine traces, could still be detected in the serum and urine samples taken on the fifth day. Since only 40 µL of the five-day-serum sample were left for the analysis, the clozapine trace peak was calculated by extrapolation and resulted in a clozapine concentration of approximately 1 ng/mL. The urine concentration of clozapine from the first day was 193 ng/mL. Half-life of clozapine in serum is approximately 11 h. Norclozapine concentrations decreased from 300 to 2.9 ng/mL (5th day) in serum and from 1730 to 17.7 ng/mL (5th day) in urine. Still, the last urine sample (11th day) showed a trace amount, yielding a concentration below the limit of quantification. Clozapine-N-oxide concentrations decreased from 174 to 2.0 ng/mL (3rd day) in serum and from 5500 to 10.7 ng/mL (5th day) in urine. We also received one cerebrospinal fluid specimen taken the first day of hospitalization. Lacking blank matrix, a calibration was established with an isotonic solution of sodium chloride. Cerebrospinal fluid concentrations were as follows: norclozapine 2.0 ng/mL, clozapine 3.6 ng/mL and clozapine-N-oxide 1.3 ng/mL.

Conclusions: To date it remains unclear where and when the girl ingested the clozapine. According to the attending pediatricians, the clinical observation and the psychological assessment of the family did not arouse any suspicion for intentional poisoning or Munchausen-by-proxy.

Key Words: Clozapine, Intoxication, LC-MS/MS

Development of Two Monoclonal Antibodies for the Broad Detection of Barbiturates and for the Detection of Meperidine and the Metabolite Normeperidine

Peter Ratcliffe, **M. El Ouard Benchikh**,* Philip Lowry, R. Ivan McConnell, and S. Peter Fitzgerald
Randox Laboratories Ltd., Crumlin, United Kingdom

Objectives: Barbiturates are central nervous system (CNS) depressants and can be used as sedatives, hypnotics, anaesthetics and anti-epileptic drugs. Monitoring the use or misuse of barbiturates is of interest to forensic, toxicological and therapeutic applications. The monoclonal antibody developed in this study exhibits not only broad specificity, but also high sensitivity for long and short-acting barbiturates enabling an enhanced detection window. Meperidine is used as an analgesic; the metabolite normeperidine is a weak analgesic but a potent CNS irritant. Normeperidine can cumulate in patients receiving repeated doses of meperidine as its elimination is slower than that of the parent compound. This study also reports the development of a novel monoclonal antibody that recognizes both compounds providing improved detection capability. The aforementioned antibodies are of value in the development of immunoassays for the detection of these drugs in biological samples for application to therapeutic and forensic toxicology fields.

Methods: The monoclonal antibodies reported here were developed according to established procedures. For the monoclonal antibody of barbiturates, sheep were immunized with secobarbital conjugated to bovine thyroglobulin (BTG) as an immunogenic carrier. For the monoclonal antibody of meperidine and its metabolite, sheep were immunized with normeperidine conjugated via an amino group to the carrier protein BTG. The corresponding lymphocytes were collected and fused with heteromyeloma cells. Supernatants from the resulting hybridomas were screened for the presence of antibodies using competitive Enzyme Linked Immunosorbent Assay (ELISA)-based assays. Positive hybridomas were cloned to produce stable monoclonal hybridomas. The antibodies were purified and the initial evaluation of specificity and sensitivity was performed by competitive immunoassays in a buffer matrix.

Results: On an ELISA-based immunoassay, the monoclonal antibody to barbiturates presented cross-reactivity values (relative to 100% phenobarbital) of 638% (alphenal), 313% (secobarbital), 225% (aprobarbital), 97% (butabarbital), 74% (amobarbital), >70% (butalbital), 54% (pentobarbital) and 14% (barbital). The sensitivity, expressed as IC₅₀, was 0.868 ng/mL for phenobarbital. On a biochip-based immunoassay, the monoclonal antibody to meperidine and metabolite presented cross-reactivity values of 100% (normeperidine) and 102.5% (meperidine). The sensitivity value, expressed as IC₅₀, was 0.491 ng/mL for normeperidine and 0.479 ng/mL for meperidine.

Conclusions: The initial evaluation shows the development of two monoclonal antibodies, one of them exhibiting high sensitivity and specificity for a wide range of barbiturates and the other enabling detection of meperidine and normeperidine specifically. This work will be valuable in developing effective immunoassays for the determination of these compounds with an enhanced detection window in biological samples for application to therapeutic and forensic toxicology fields.

Key Words: Barbiturates, Meperidine, Normeperidine, Antibodies

Application of Matrix Dedicated Evidence Biochip Array Kits to the Simultaneous Determination of Tricyclic Antidepressants (TCAs), Buprenorphine, Methylenedioxymethamphetamine (MDMA) and Other Drugs of Abuse in Urine and Blood

Darragh, J., Finnegan, C., Kelly, F.M., Holmes, P., Piper, M.,* McConnell, R.I., and Fitzgerald, S.P.
Randox Laboratories Ltd., Crumlin, United Kingdom

Objectives: The use of different sample types is now commonplace in test settings. There are limitations with generic methodologies for the analysis of different matrix types, which require different sample dilutions to achieve the different cut-offs corresponding to the matrix type analysed. Moreover, preparation of calibrators and buffers to achieve the analytical requirements for a particular sample type can introduce errors and variations in the measurements. Evidence biochip array technology provides a platform for the simultaneous screening of TCAs, buprenorphine, MDMA and other drugs of abuse from a single sample using matrix dedicated kits. This study presents the applicability of this technology to the simultaneous semi-quantitative determination of these compounds in urine and whole blood.

Materials and Methods: The core of this technology is the biochip, which represents the solid phase where the ligands are immobilised and stabilised defining microarrays of test sites and also the vessel where the reactions take place. Competitive chemiluminescent simultaneous immunoassays applied to the fully automated Evidence analyser were employed. The system incorporates the software to process, report and archive the data generated.

Results: The TCA assay detects 18 out of 22 compounds (% cross-reactivity >10%) in urine matrix and 19 out of 21 compounds in whole blood; including desipramine, nortryptiline and trimipramine (% cross-reactivity: 131%, 100%, 375% respectively in urine and 206%, 100% and 238% respectively in whole blood). The lowest concentrations of TCA, buprenorphine and MDMA that can be distinguished from the zero calibrator (analytical sensitivity) were 7.2 ng/mL, 0.04 ng/mL, 7.06 ng/mL respectively in the application to urine and 2.78 ng/mL, 0.05 ng/mL and 2.26 ng/mL respectively in the application to whole blood. For other drugs of abuse, these concentrations ranged from 0.04 ng/mL (opiates) to 50.9 ng/mL (methamphetamine) in the application to urine and from 0.1 ng/mL (oxazepam) to 22.2 ng/mL (methamphetamine) in the application to whole blood. The lowest concentrations of TCA, buprenorphine and MDMA that can be detected from negative sample (limit of detection, LOD) were 12.8 ng/mL, 0.005 ng/mL, 22.6 ng/mL respectively in urine and 4.22 ng/mL, 0.3 ng/mL, 7.72 ng/mL respectively in whole blood. For other drugs of abuse the LOD values ranged from 0.1 ng/mL (phencyclidine) to 84.5 ng/mL (amphetamine) in urine and from 0.27 ng/mL: (benzoylecgonine) to 27 ng/mL (methamphetamine) in whole blood. LODs were determined as average concentration of negative samples (n=20) + 2SD. For all the assays the intra and inter-assay precision, expressed as %CV, were <13%, <19% respectively in the application to urine and <17.7%, <20% respectively in the application to whole blood.

Conclusion: Data show applicability of this technology to the simultaneous semi-quantitative determination of TCAs, buprenorphine, MDMA and other drugs of abuse in urine and blood with matrix-dedicated kits. This is of value for applications in therapeutic drug monitoring, toxicology and forensic toxicology.

Key Words: Tricyclic Antidepressants, Buprenorphine, Drugs of Abuse, Biochip Array

Development of a Highly Sensitive Polyclonal Antibody for Measuring Lidocaine in Biological Samples

Philip Lowry, M. El Ouard Benchikh, **Michelle Lowry**,* R. Ivan McConnell, and S. Peter Fitzgerald
Randox Laboratories Ltd., Crumlin, United Kingdom

Objectives: Lidocaine was originally developed as a local anaesthetic. However, it also possesses antiarrhythmic properties, particularly against ventricular arrhythmics and is widely used in the treatment of post-myocardial infarction. The toxic side effects of lidocaine, hypertension, CNS depression and convulsions, appear to be avoidable if the levels in blood do not exceed 5 µg/mL. We report the development of a sensitive polyclonal antibody to lidocaine for use in the development of immunoassays. This will facilitate the optimum therapeutic management of patients treated with this compound.

Materials and Methods: A novel hapten to lidocaine was synthesized and conjugated directly to bovine thyroglobulin (BTG) as carrier. The resulting immunogen was administered to adult sheep and a lidocaine specific polyclonal antiserum was generated. Immunoglobulin fraction was extracted and evaluated via competitive enzyme-linked immunosorbent assay (ELISA). Absorbance was read at 450 nm.

Results: Initial evaluation of the developed polyclonal antibody was performed in a buffer matrix for the calibration range 0-100 ng/mL. The specificity, expressed as %cross-reactivity value, was 100% for lidocaine and <2.2% for the most structurally similar metabolite norlidocaine. The sensitivity, expressed as half maximal inhibitory concentration (IC₅₀), was 2.2 ng/mL for lidocaine. The intra-assay precision, expressed as %CV (n=3), was typically <7.5% for different concentration levels.

Conclusion: These results indicate that the polyclonal antibody generated is highly sensitive and suitable for development of immunoassays for the determination of lidocaine in biological samples.

Key Words: Lidocaine, Immunoassays, Polyclonal Antibody

Use of anabolic-androgenic steroids in connection with violent crimes

Yvonne Lood*, Arne Eklund and Johan Ahlner

Department of Forensic Genetics and Forensic Toxicology, National Board of Forensic Medicine, Artillerigatan 12, SE-587 58 Linköping, Sweden

Objectives: Use of anabolic-androgenic steroids (AAS) is associated with adverse psychiatric side effects such as aggression, and violent behavior, and may be escalated to unprovoked rage and serious criminality. AAS are mainly used for their powerful effects on muscle strength and mass. The significance and use of supraphysiological doses of AAS and other illicit drugs in AAS-related violence has been discussed in the scientific literature. AAS are controlled substances in Sweden and their use has been prohibited since 1999. At the Department of Forensic Toxicology, AAS and other illicit and licit drugs are determined in body fluids at the request of the police authority. The aim of this study was to investigate and evaluate the analytical results and the incidence of AAS and poly-drug abuse in suspected perpetrators arrested for violent crimes.

Material and Methods: Data were collected from the toxicological analyses performed on blood and urine specimens in the cases of violent crimes sent to the laboratory by the police authority from 2006 until 2010. Type of criminal act, age and gender, anabolic substances used and the presence of other illicit and licit drugs at the time of the crime were analyzed. We also investigated the rate of re-arrests for the AAS users involved in the violent crimes. AAS, ethanol, licit and illicit drugs were determined by GC-MS, LC-MS/MS, GC-NPD and GC-headspace. A forensic toxicology database (Toxbase32) was used.

Results: Of the 954 cases of violent crimes screened for AAS, 92 (9.6%) tested positive for AAS. The AAS users were exclusively men aged 27.1 ± 5.7 (mean \pm SD) years old, median age 26. The criminal acts included homicide, attempted homicide, manslaughter, rape, indecent assault, abduction, assault, serious case of assault, robbery, serious case of robbery and threat. The most frequently used AAS were nandrolone and testosterone followed by stanozolol and boldenone. AAS were combined with other drugs in 61 (66.3%) of the AAS users with cannabis, amphetamine and benzodiazepines most frequently used. Ethanol was positive in 18 (29.5%) of the cases. Of the 92 AAS users, 63 (68.5%) had multiple arrests for drug-related offences, a total of 565 times (mean 6.1 times, median 4 times, range 1-47 times). A following up of the AAS users, revealed that four were registered as death cases, caused by drug intoxication and one by suicide.

Conclusion: The results indicate that AAS abuse is connected with serious criminal acts and often in combination with use of other drugs of abuse. Several of the young men were drug addicts, with multiple arrests for drug offences, impaired driving and/or violent crimes. The study also suggests that abuse of AAS increases the risk of premature death.

Key Words: Anabolic Androgenic Steroids, Forensic Toxicology, Violent Crimes

Observations on Methadone Co-Prescriptions and Non-Prescription Medications in a Pain Patient Population

Robert West*, Amadeo Pesce, Perla Almazan, Charles Mikel, Cameron West, Murray Rosenthal, Sergey Latyshev and Elizabeth Gonzales

Millennium Research Institute, 16981 Via Tazon, San Diego, CA 92127, USA

Objectives: The high death rate observed in methadone patients is largely related to its use in the treatment of pain. The co-ingestion of other medications, especially other opiates, benzodiazepines and alcohol, are frequently implicated in these deaths. In an attempt to better understand these deadly combinations, Millennium Research Institute conducted a retrospective study of de-identified LC-MS/MS and prescription data from 290,627 samples collected by pain clinics nationwide between November 2009 and September 2010.

Materials and Methods: This data set was filtered to include samples from patients prescribed methadone resulting in a cohort of 20,974 samples. This data set was further analyzed to determine the prescription patterns and LC-MS/MS positivity rates. Drugs included in each class include: opiates (codeine, morphine, hydrocodone, hydromorphone, oxycodone, oxymorphone), benzodiazepines (alprazolam, clonazepam, lorazepam, oxazepam, temazepam, diazepam, chlordiazepoxide, clorazepate), soma (carisoprodol, meprobamate), fentanyl, amphetamine (amphetamine, dextroamphetamine), tramadol, buprenorphine, propoxyphene, tapentadol, and meperidine.

Results: Results are summarized below.

Table 1. Prescribed medications and observed excretion products analyzed in the study.

Specimens with Methadone Prescriptions (N=20,974)					
Medication/ Medication Class	Prescribed		Confirmed by LC-MS/MS		% Difference
	N	%	N	%	
Methadone	20,974	100.0%	18,716	89.2%	-10.8%
Opiates	13,044	62.2%	11,440	54.5%	-12.3%
Benzodiazepines	6,695	31.9%	8,885	42.4%	32.7%
Soma	2,370	11.3%	2,077	9.9%	-12.4%
Fentanyl	690	3.3%	738	3.5%	7.0%
Amphetamine	436	2.1%	963	4.6%	120.9%
Tramadol	540	2.6%	483	2.3%	-10.6%
Buprenorphine	255	1.2%	270	1.3%	5.9%
Propoxyphene	156	0.7%	449	2.1%	187.8%
Tapentadol	99	0.5%	47	0.2%	-52.5%
Meperidine	53	0.3%	58	0.3%	9.4%

Conclusions: The opiates and benzodiazepines were the most commonly co-prescribed medications with frequencies of 62% and 32%, respectively. In a significant number of patients, benzodiazepines were detected in the absence of a prescription. As the combination of these drugs and methadone are considered potentially hazardous, these observations may help to explain the high death rate among pain patients receiving methadone.

Key Words: Methadone, Co-prescriptions, Pain Patient Population

Characterization of Genetic Variants of Human Serum Transferrin

Simona Martello¹, Marialinda Felli¹, Eleonora De Vincenzi¹, **Paolo Emilio Santoro**^{2*}, Antonio Bergamaschi², Gennaro Palma³, Maria Luigia Cerabino³, Carmela Fraietta³ and Marcello Chiarotti¹.

¹Catholic University of the Sacred Heart (UCSC), Forensic Toxicology Analytical Unit, Rome, Italy; ²Catholic University of the Sacred Heart (UCSC), Institute of Occupational Medicine, Rome, Italy; ³Rete Ferroviaria Italiana (RFI), Direzione Sanità, Rome, Italy

Objectives: Human transferrin (Tf) is a serum iron transporting protein composed of amino acids with two potential glycosylation sites, which usually bind carbohydrate chains of variable composition, containing four different carbohydrates. The asialo, monosialo and disialo isoforms are referred to as CDT (Carbohydrate-deficient transferrin). Nowadays, CDT is a biomarker for identifying excessive alcohol intake and monitoring abstinence during treatment. The prevalent literature supports the correlation between alcohol intake and CDT concentrations, and according to the literature, after sustained alcohol intake, an increase of CDT serum concentration occurs. In this study, genetic variants of human serum transferrin, which may interfere with the immunometric determination, were determined using N Latex CDT, capillary electrophoresis (CE) and HPLC-UV. The Siemens N Latex CDT method directly determines CDT in serum or plasma using a competition between CDT in the sample and CDT-coated polystyrene particles and a specific monoclonal antibody against human CDT. The N Latex CDT method analyzes genetic transferrin variants with reduced interference.

Materials and Methods: Sera samples (n=52) were initially analysed for CDT using capillary electrophoresis in the Biochemical Analysis Laboratory of Rete Ferroviaria Italiana (RFI). Genetic variants B and D were selected and tested with HPLC-UV and N Latex CDT. The three techniques used a commercial kit for CDT determination (kit Analis, ClinRep Recipe and N Latex CDT Siemens). The samples were also checked for GOT (glutamic-oxaloacetic transaminase), GPT (Glutamic-pyruvic transaminase), MCV (mean corpuscular volume) and GGT (γ -glutamyltransferase).

Results: Using a cut-off limit of 2.5%, all the 52 sera samples analyzed by N Latex CDT were classified as negative; however, specimens analyzed with CE and HPLC showed a genetic variant for transferrin. The genetic transferrin variant D was 9.6% of all the variants analysed and gave negative results with at a higher percentage than the genetic variant B.

Conclusions: An important problem with traditional immunoassays is that the antisera used are directed towards whole human transferrin, without any specificity for CDT components. Abnormal genetic Tf variants may interference with the immunometric determination. Transferrin D and transferrin B may produce false-negative results when immunometric methods are used. The N Latex CDT does cause false negative results due to genetic variations. In forensic toxicology, HPLC-UV and capillary electrophoresis (CE) are the best choices for CDT determination.

Key Words: CDT, Genetic Variants, HPLC-UV Analysis

Validated Analytical Method for the Determination of Meta-Chlorophenylpiperazine (m-CPP) in Human Plasma and Urine by Liquid Chromatography-Tandem Mass Spectrometry (LC-MS/MS)

Daniel Ninello Polesel*^{1,4}, José Luiz da Costa², Rafael Lanaro³ and Marina Franco Maggi Tavares^{1,4}

¹Faculty of Pharmaceutical Sciences, University of São Paulo, SP, Brazil; ²Criminalistic Institute of Sao Paulo, SP, Brazil;

³Faculty of Medical Sciences, State University of Campinas, SP, Brazil; ⁴Institute of Chemistry, University of São Paulo, SP, Brazil

Introduction: Meta-chlorophenylpiperazine (m-CPP) is a synthetic drug often used in nightclubs and in rave parties. The central nervous system effects of the drug include feeling of restlessness, euphoria and hallucinations, comparable to those produced by MDMA. Toxic effects caused by m-CPP, include anxiety, agitation, panic attacks, hypertension and tachycardia. Reported cases of acute ingestion of approximately 90 mgs of m-CPP resulted in plasma and urine levels above 300 ng/mL.

Objectives: To establish a simple method for the extraction and quantification of m-CPP in human plasma and urine.

Materials and Methods:

Method for Plasma: Negative plasma (200 µL) was spiked with the following concentrations of m-CPP: (10, 25, 50, 100, 250, 500 and 1000 ng/mL), added to a 2 mL conical polypropylene tube containing 50 µL of the methanolic solution of the internal standard (o-CPP, 250 ng/mL). In addition, 150 mg of NaCl (for salting-out effect), 50 µL of 1 M sodium hydroxide and 1 mL of methyl tert-butyl ether (MTBE) were added. After vortexing for 5 minutes and centrifuging at 12,500 rpm for 5 minutes, the supernatant was evaporated to dryness under nitrogen at room temperature. The residue was reconstituted with 200 µL of mobile phase. A 25 µL aliquot was injected for analysis.

Method for Urine: Negative urine (400 µL) was spiked with the following concentrations of m-CPP: (7.5, 50, 100, 500, 1000, 5000), added to a 2 mL conical polypropylene tube containing 100 µL of the methanolic solution of the internal standard (o-CPP, 500 ng/mL). In addition, 300 mg of NaCl, 100 µL of 1 M sodium hydroxide and 1 mL of MTBE were added. After vortexing for 5 minutes and centrifuging at 12,500 rpm for 5 minutes, the supernatant was evaporated to dryness under nitrogen. The residue was reconstituted with 400 µL of mobile phase and 25 µL were injected for analysis.

LC-MS/MS: The chromatographic separation was performed on a Zorbax Eclipse XDB-C18 (4.6 mm x 150mm x 5µm) column eluted isocratically with acetonitrile:water (containing 0.1% formic acid) (75:25 v/v) at a flow rate of 1 mL/min and total run time of 5 minutes. The mass spectrometer (LCQ DECA XP MAX - Ion Trap) was operated under positive electrospray ionization and set to MRM mode with the following transitions: 197→119, 197→154.

Results:

Results in Urine: The method reliably provided a LOD of 5 ng/mL and LOQ of 7.5 ng/mL. The precision (% CV) was 4.8%, 3.4% and 9.2% for the controls at 25, 250, and 5000 ng/mL, respectively (n=5). The accuracy was 92.1%, 88.5% and 89.6% for the respective controls. In the linearity study, heteroscedasticity was checked; a weighting factor of $1/X^2$ provided the lowest value for the sum of errors (-0.01%) and a coefficient of determination of 0.996.

Results in Plasma: The method LOD was 5 ng/mL and the LOQ was 10 ng/mL. The precision (% CV) was 12.1%, 5.6%, and 3.3% in controls at 10, 100, and 1000 ng/ml respectively (n=5). The accuracy was 56.6%, 106.7% and 3.3% for the respective controls. In the linearity study, heteroscedasticity was checked; a weighting factor of $1/X$ provided the lowest value for the sum of errors (0.00%) and a coefficient of determination of 0.994.

Discussion: The method has been successfully used in the investigation of CCI-UNICAMP cases of acute poisoning by m-CPP.

Key Words: Meta-Chlorophenylpiperazine, m-CPP, Plasma, Urine, LC-MS/MS

The Relationship Between Agouti-Related Protein (AgRP) and Leptin in Cannabis Smokers

W. M. Fathy*

Forensic Medicine Institute, Chemistry Lab. Ministry of Justice, Cairo, Egypt

Introduction: Leptin is an adipocyte-derived hormone that is secreted in correlation with total body lipid stores. Cannabinoid components of cannabis are known to exert behavioral and psychotropic effects but also to possess therapeutic properties including analgesia, ocular hypotension, and antiemesis. Agouti-related protein (AgRP), a homolog produced in the arcuate nucleus of the hypothalamus and the adrenal gland, is an antagonist of the central melanocortin receptors, and is one of the most potent and long-lasting of appetite stimulators.

Objective: To determine the food intake mechanism in cannabis smoking subjects by studying the relationship between the key hormones of food intake control (leptin and AgRP hormones), and comparing with healthy, non-cannabis smokers.

Methods: Control Group I (GI) included 10 volunteers, healthy male (age mean \pm SD 38.7 \pm 2.3 y) with negative 11-nor-9-carboxy-tetrahydrocannabinol (THCCOOH) urine specimens. Group II (GII) included 10 males (age mean \pm SD 37.4 \pm 2.7 y), with THCCOOH positive urine specimens detected by qualitative analysis using gas chromatography-mass spectrometry (Agilent 6080N; HP-5ms; 30m X 0.25mm X 0.25 μ m) and collected by the Forensic Medicine Institute Chemistry Lab. in Cairo, Egypt. Age and body-mass index (BMI) were matched, diabetic subjects were excluded. Plasma leptin concentrations were measured by quantitative radioimmunoassay (RIA) using a kit supplied by Diagnostic Systems Laboratories (DSL) Inc. (Webster, TX, USA). The method depends on a non-competitive assay in which the measured analyte is bounded between two antibodies. Plasma AgRP hormone was quantitatively measured by a Quantikine[®] kit supplied by R&D Systems Inc. (Minneapolis, MN, USA). This assay employs the quantitative “sandwich” enzyme immunoassay technique (ELISA). Statistical analysis was done by a Minitab 14 software.

Results: In GI, the mean \pm SD plasma leptin concentrations (6.39 \pm 1.93 ng/mL) were higher than in GII (4.49 \pm 1.40 ng/mL), but the difference was statistically insignificant ($P > 0.05$). Mean plasma AgRP concentrations (27.77 \pm 2.17 pg/mL) were higher in GII compared to GI (25.84 \pm 1.93 pg/mL), but the difference was statistically insignificant ($P > 0.05$). There was a statistically significant inverse correlation between plasma leptin and AgRP concentrations in GI ($P < 0.05$) with $S = 1.30$, $R\text{-Sq} = 59.6\%$, $R\text{-Sq}(\text{adj}) = 54.5\%$. A proportional correlation was found between plasma leptin concentrations and plasma AgRP concentrations in GII but it was statistically insignificant ($P > 0.05$) with $S = 2.22$, $R\text{-Sq} = 7.6\%$, $R\text{-Sq}(\text{adj}) = 0.0\%$.

Conclusion: The relationship between plasma leptin and plasma AgRP concentrations may be affected by cannabis smoking, and that may alter food intake mechanisms. A larger sample size is needed to confirm or refute this possibility.

Key Words: Leptin, Agouti-Related Protein, Cannabis

Identification of Human Hepatic UDP-Glucuronosyltransferases (UGTs) Involved in Metabolism of Ethanol

Alaa AlSaabi^{1,2,4}, Delphine Allorge^{1,2}, François-Ludovic Sauvage^{4,5}, Gilles Tournel^{1,3}, Jean-michel Gaulier⁵ and Nicolas Picard^{4,5}

¹EA4483, Faculty of Medicine, Univ. Lille-Nord de France, Lille, France; ²CHRU Lille, Laboratory of Toxicology, Lille, France; ³CHRU Lille, Institute of Forensic Medicine, Lille, France, ⁴INSERM, UMR-S850, Laboratory of Medical Pharmacology, Univ. Limoges, Limoges, France, ⁵CHU Limoges, Department of Pharmacology and Toxicology, Limoges, France

Objectives: Ethylglucuronide (ethyl- β -D-6-glucuronide, EtG) is a phase-II metabolite of ethanol. Its determination has recently gained importance in forensic toxicology as a direct biomarker of ethanol consumption. However, the enzymes involved in this glucuronidation pathway are still not clearly established in humans. The aim of this study was to determine the individual contribution of 9 major UDP-glucuronosyltransferases (UGTs) to the hepatic glucuronidation of ethanol.

Materials and Methods: Ethanol (0.05 – 1000 mM) was incubated with pooled human liver microsomes (HLM), as well as with baculovirus infected-insect cell microsomes each expressing a major human hepatic UGT (Supersomes[®]; UGT1A1, 1A3, 1A4, 1A6, 1A9, 2B4, 2B7, 2B15 and 2B17). Kinetic parameters (apparent affinity K_m , maximal velocity V_{max} and intrinsic clearance Cl_{int}) were calculated using both HLM and active recombinant UGTs. The individual contribution of each UGT was estimated using the relative activity factor (RAF) approach, proposed for scaling enzymatic activities obtained with cDNA-expressed enzymes to HLM. RAFs (i.e. HLM/Supersomes[®] activity ratio of a particular isoform towards a probe substrate) were calculated for UGT1A3, UGT1A4, UGT1A9 and UGT2B7 using selective substrates. The determination of EtG concentrations was performed using LC-MS/MS (API 4000, AB Sciex).

Results: HLM showed a very low-affinity/high-capacity for ethanol glucuronidation ($K_m=1036.7 \pm 348.5$ mM; $V_{max}=725$ pmole/mg/min). Incubation with recombinant enzymes revealed that all the UGTs tested, except UGT1A1 and 1A6, are able to produce EtG in detectable amounts. However, using the RAF approach, UGT1A9 and 2B7 were determined to be the major enzymes involved in ethanol hepatic glucuronidation, each contributing 12.1 and 71.6% of the Cl_{int} of HLM, respectively. The contribution of UGT1A3 and 1A4 was estimated at 3.1% and 2.1%, respectively. The remaining 11.1% of EtG production can be likely attributed to UGT2B4, 2B15 and 2B17.

Conclusion: UGT1A9 and 2B7 were clearly identified as the main human UGTs involved in ethanol glucuronidation. Both isoforms are expressed in the liver and kidneys, suggesting that kidneys could also play a role in EtG formation. Furthermore, the implication of intestinal UGT isoforms (UGT1A7, 1A8 and 1A10) remains to be studied. Genetic variations in UGT1A9 and 2B7 and drug interactions with these enzymes could thus contribute to the inter-individual variability in EtG production (and subsequently observed concentrations) and should be investigated.

Key Words: Ethanol, Ethylglucuronide, UDP-Glucuronosyltransferase (UGT)

Production of Recombinant Hydroxyacid-Oxoacid Transhydrogenase and its Application to Measure Gamma Hydroxybutyrate by a Colorimetric Assay

Samar Alzeer*, Andreas Panopoulos and Elizabeth M. Ellis

Strathclyde Institute of Pharmacy and Biomedical Sciences, University of Strathclyde, Glasgow, G4 0RE, Scotland, UK

Objectives: Gamma hydroxybutyrate (GHB) is encountered in drug-facilitated sexual assault cases. GHB identification in such cases can be problematic because it is rapidly metabolized and eliminated from the body. Its window of detection is limited to approximately 5 h in blood, and 12 h in urine. GHB is metabolized to succinic semialdehyde (SSA), which is converted to succinate and enters the tricarboxylic acid cycle (TCA) cycle. Hydroxyacid-oxoacid transhydrogenase (HOT) is an iron-dependent alcohol dehydrogenase that was proposed to oxidize GHB to SSA using α -ketoglutarate as a co-substrate. The gene encoding HOT has been cloned and identified as *ADHFe1*. In this study, recombinant HOT was expressed and purified, and its use in an assay for detecting GHB was investigated.

Materials and Methods: To produce sufficient HOT for the study, the *ADHFe1* gene was amplified by polymerase chain reaction (PCR) from rat liver. A band corresponding to the amplified gene appeared at the expected size (1.4 KB); this was cloned and its identity confirmed by DNA sequencing. The amplified gene was subcloned into the expression vector pET-15b under the control of an IPTG-inducible T7 promoter, and with an N-terminal polyhistidine (His) tag. Following transformation into *Escherichia coli* BL21 pLysS, expression of the gene was induced in mid-logarithmic cells for 3 h using 0.1 mM of isopropyl β -D-1-thiogalactopyranoside (IPTG). Samples before and after induction were analyzed by sodium dodecyl sulfate polyacrylamide gel electrophoresis (SDS-PAGE) and Western blots for presence of recombinant HOT using an anti-His antibody. This antibody detected a specific band corresponding to the His-tagged recombinant protein. HOT purification was performed under denaturing conditions using affinity chromatography on a nickel-agarose column and purified protein was eluted using an imidazole gradient. Refolding of the enzyme was performed using size-exclusion chromatography on a Sephadex™ G-25 Superfine column.

Results: The purity of the expressed protein was 98%. The yield was 1 mg/L of bacterial culture. MS/MS analysis after trypsin digestion confirmed the identity of the protein as HOT. Enzyme assays on refolded HOT were performed at 37 °C in glycine buffer pH 9, using 50 μ M of GHB and α -ketoglutarate as co-substrate. SSA production was measured by formation of an azine with 3-methyl-2-benzothiazolinone-2-hydrazone (MBTH). The azine was allowed to react with a second molecule of MBTH to produce a coloured product with absorbance at 660 nm which was measured on a Perkin Elmer Lambda 12 spectrometer. Results from this assay showed that HOT has a specific activity of 440 nmol/min/mg of protein. The limit of detection for SSA by the colorimetric assay was 2.5 nmoles and the assay was linear between 2.5 and 40 nmoles of SSA and was performed in triplicate. R^2 was 0.9996. The assay was sensitive enough to detect 50 μ moles of GHB. GHB consumption in parallel to SSA formation should be verified by GC/MS.

Conclusion: These results demonstrate the successful production and purification of active HOT, and the potential application of the enzyme for the detection of micromolar concentrations of GHB using a simple colorimetric assay. This has the potential for use in a range of forensic applications. Enzyme kinetics are yet to be determined.

Key Words: Gamma Hydroxybutyrate, Hydroxyacid-Oxoacid Transhydrogenase, Succinic Semialdehyde

P232

WITHDRAWN

Forensic Aspects of Teargas Toxicity**Ahmed M. Bendary***

Forensic Medicine Authority, Cairo, Egypt

Objectives: Teargas is a non-specific term for any chemical used to cause temporary incapacitation through irritation of the eyes and/or the respiratory system. This study is not only concerned with the traditional analysis of tearing materials in biological samples but also of the products of thermal decomposition when the solid content of the grenades are converted to gas "smoke" form. The thermal decomposition products form 50-70% of the smoke. Potassium chlorate/perchlorate and nitrocellulose commonly used in teargas devices and are classified as explosive materials. This study attempts to relate the analyses of post-explosion chemicals and teargas components.

Materials and Methods: From each of three persons said to be exposed to teargas one blood sample was collected after exposure. CS "o-Chlorobenzylidenemalononitrile" a tear inducing agent and its metabolites were extracted by liquid-liquid extraction method. Extracts were concentrated and analyzed using gas chromatography with electron impact mass spectrometry (GC/EI-MS). Hp-5 column (30.0 x 25 cm x 0.25 μ m) with He carrier gas was used at a flow rate of 0.8 ml/min. Carboxyhemoglobin and cyanohemoglobin are two of the toxic compounds formed after exposure to teargas. Ultraviolet spectrophotometry was used to detect carboxyhemoglobin. Cyanide was detected by blood distillation followed by colorimetric test of ferrocyanide complex formation (Prussian blue color).

Experimentally three rats were exposed to the combustion smoke in a closed area. A blood sample was collected from each rat separately after exposure. The serum was deproteinized using an acetonitrile procedure. The thermal decomposition products perchlorate, chlorate, chloride and nitrite were determined following centrifugation. The deproteinized extract was concentrated and analyzed using ion chromatography with a conductivity detector (IC-CD). The column was an Ionpac AS 19 (4 x 250 mm) and the elution solution 10-40 mmol KOH at a flow rate of 1 ml/min.

Results: CS "o-Chlorobenzylidenemalononitrile" and its metabolite 2-Chlorobenzaldehyde were detected in the blood sample of one person. Carboxyhemoglobin was detected in another person's blood sample above the expected concentration, while cyanohemoglobin was not detected in any of the three analyzed human blood samples. Thermal decomposition products were not detected in the blood of exposed persons. As for samples collected from rats; perchlorates, chlorates, chloride and nitrites were detected by ion chromatography-conductivity detector in addition to the anions found in normal blood IC analysis.

Conclusion: Analytical toxicologists and forensic chemists are interested in detecting carboxyhemoglobin, cyanohemoglobin and o-chlorobenzylidene malononitrile metabolites in biological samples. The present study stresses the importance of detecting the thermal decomposition inorganic products, since they are known to form methemoglobin that can cause death due to lack of oxygen.

Key words: Teargas Toxicity, Methemoglobinemia, CS Teargas, O-Chlorobenzylidene Malononitrile

Cross-Reactivity of Tapentadol Specimens with DRI[®] Methadone Enzyme Immunoassay

Ayodele Collins*, Paola Merritt and James Bourland
Ameritox, Ltd., Midland, TX, USA

Objectives: A substantial incidence of positive methadone screens for pain management urine specimens using a commercial enzyme immunoassay (EIA) was observed in the absence of a methadone prescription, with negative methadone confirmation by ultra-performance liquid chromatography tandem mass spectrometry (UPLC/MS/MS). A review of the associated medication lists revealed the novel synthetic analgesic, tapentadol, as the only common prescription amongst the investigated specimens. The DRI[®] methadone immunoassay (Microgenics Corp., Fremont, CA, USA) package insert indicated no evaluation of cross-reactivity with tapentadol. Extensive phase II biotransformation of tapentadol generates tapentadol glucuronide and tapentadol sulfate as the major urinary biomarkers. Unchanged tapentadol and the phase I metabolite, *N*-desmethyltapentadol, are also eliminated in urine.

Materials and Methods: Aliquots of drug-free urine fortified separately with tapentadol or one of its three major metabolites at various concentrations (100-500,000 ng/mL) were tested against the DRI[®] methadone EIA, to evaluate cross-reactivity. Authentic tapentadol urine specimens that produced false-positive methadone EIA results at a 130 ng/mL cut-off (n=97) were sequestered and analyzed for methadone and for tapentadol, tapentadol glucuronide, tapentadol sulfate and *N*-desmethyltapentadol in compound-specific confirmation tests by UPLC/MS/MS.

Results: Cross-reactivity was calculated as the percentage of the concentration reading of the methadone EIA assay to the lowest concentration of tapentadol analyte triggering a positive response. Tapentadol, tapentadol glucuronide, tapentadol sulfate and *N*-desmethyltapentadol, exhibited cross-reactivity with the methadone EIA at 7,000 (2.2%), 25,000 (0.5%), 3,000 (4.4%) and 15,000 ng/mL (0.9%), respectively. All authentic urine specimens confirmed as negative for methadone, but positive for tapentadol and all three monitored metabolites. Confirmation detection limits were 25 ng/mL for tapentadol glucuronide and tapentadol sulfate, 50 ng/mL for methadone and 100 ng/mL for tapentadol and *n*-desmethyltapentadol. Concentrations of tapentadol and its metabolites ranged from 121-1,719,134 ng/mL. Individual concentrations did not always exceed the cross-reactivity limits for each analyte, but total measured tapentadol exceeded 7,000 ng/mL in all specimens. This indicated that separate or combined urinary concentrations of tapentadol and its conjugates may produce false-positive methadone screens through cross-reactivity with the methadone immunoassay. Cross-reactivity was observed despite structural dissimilarities between methadone and tapentadol derivatives.

Conclusion: The cross-reactivity of tapentadol and its major metabolites with the DRI[®] methadone EIA was demonstrated. Microgram levels of total tapentadol were detected in tapentadol specimens. The potential for false-positive results for methadone EIA screening of urine specimens associated with tapentadol prescriptions must be considered when interpreting results.

Key Words: Tapentadol, Methadone, Cross-Reactivity

P235

WITHDRAWN

Quantitative U-HPLC-MS Analysis of 14 Benzodiazepines in Urine Using a High Resolution Accurate Mass Exactive Mass Spectrometer Equipped with a Higher Energy Collisional Dissociation CellXiang He^{*1}, Robert Era², and Marta Kozak¹¹ThermoFisher Scientific, San Jose, CA, USA; ²Fortes Laboratory, Wilsonville, OR, USA

Objectives: To develop a quantitative ultra high performance liquid chromatography mass spectrometry (U-HPLC-MS) method for 14 benzodiazepines in urine with a High Resolution Accurate Mass (HRAM) mass spectrometer using Higher Energy Collisional Dissociation cell (HCD) fragmentation for confirmation purposes.

Materials and Methods: Urine samples were spiked with 14 benzodiazepines and their corresponding internal standards and were hydrolyzed with β -glucuronidase. The mixture was diluted and subjected to U-HPLC-MS analysis. The U-HPLC-MS analysis was performed on a benchtop ExactiveTM mass spectrometer with heated electrospray ionization (HESI-II) source coupled to an Accela U-HPLC pump and a CTC autosampler. Two scan events using different mass resolutions were included during data acquisition. Full scan mass spectrometry analysis was done with resolution of 100,000 (full width at half maximum, FWHM at m/z 200) with a mass isolation window of 3 ppm using internal lock mass correction. Concurrently, an all ion fragmentation (AIF) mass scan was done with HCD at a collision energy of 40 V, and with resolution of 50,000 (FWHM at m/z 200). Exact mass was used for compound identification and a unique fragment ion was chosen for each benzodiazepine as the confirming ion, with specified ion ratio against the parent ion. U-HPLC was carried out on a Hypersil GOLD PFP column (100 \times 2.1 mm, 5 μ m particle) at room temperature.

Results:

1. We tested spiked urine from seven individual sources for 1) absolute internal standard recovery 2) consistency of ion ratios for all 14 benzodiazepines/internal standards. It was found that 1) the absolute recoveries of all the internal standards were between 83 and 101%; 2) The average coefficient of variation (CV) of ion ratios in seven lots of urine were 8.2% and 7.4% for all 14 benzodiazepines and their internal standards, respectively.
2. This quantitative method was linear from 5 to 1000 ng/mL for all 14 benzodiazepines with an accuracy of 85.4-106.0%. Inter- and intra-batch CVs at two different concentration levels (15 and 300 ng/mL) ranged from 0.5% to 11.7%. The method has a lower limit of quantitation (LLOQ) of 5 ng/mL for all 14 benzodiazepines tested.

Conclusion: We have developed a simple and reliable U-HPLC-MS method for quantitative analysis of 14 benzodiazepines in urine using a benchtop Exactive mass spectrometer. Quantitation was done by extracting the exact masses of the molecular ions of these benzodiazepines and further confirmed by evaluating the ion ratios between the characteristic HCD-generated fragment ions and their parent ions. This workflow is fast, efficient, and meets the most stringent quantitative/confirmative requirements for benzodiazepine analysis in toxicology research laboratories.

Key Words: Benzodiazepines, Urine, U-HPLC-MS, Exactive, HRAM

Urinary Levels of 1-Hydroxypyrene in Smoking and Nonsmoking Pregnant Women

Flavia Valladão Thiesen*, José Miguel Chatkin, Julia de Barros Machado, Karine Rodrigues, Carolina Mohr, and Ana Paula Szezepaniak Goulart
Pontificia Universidade Católica do Rio Grande do Sul, Porto Alegre, Brazil

Objectives: Tobacco is a public health problem and a risk factor for a variety of pathologies. Associations between fetal exposure to tobacco smoke products and indicators of fetal health status have been documented. The use of biomarkers to assess exposure to the main components present in tobacco is of paramount importance to evaluate tobacco exposure. Polycyclic aromatic hydrocarbons (PAH) are by-products of the incomplete combustion of organic materials found in tobacco smoke and show carcinogenic properties in epidemiological or animal studies. 1-Hydroxypyrene (1-OHP), a metabolite of the common PAH pyrene, is considered the most appropriate parameter to evaluate PAH exposure. The aim of this study was to measure 1-OHP urinary levels in pregnant women, in order to verify if there is a difference between these levels in smoking and nonsmoking mothers.

Methods: Forty pregnant women (aged 18 to 35 years old) belonging to a low risk group without concomitant pathologies were included in this study. On the day of delivery all participants had urine collected for evaluation of cotinine and 1-OHP. Biomarkers were measured by high performance liquid chromatography. Assessment of tobacco habit was based on urinary cotinine levels. Mean and standard deviations were used for the description of urinary 1-OHP concentrations, and one-way ANOVA was applied to compare 1-OHP levels in smoking and nonsmoking women.

Results: Among smoking mothers, mean urinary 1-OHP concentration was 0.23 umol/mol creatinine (n = 13, SD = 0.23), while in nonsmoking mothers mean 1-OHP concentration was 0.14 umol/mol creatinine (n = 27, SD = 0.11). The difference was not significant between groups (p = 0.146).

Conclusions: We present preliminary data from a study that intends to evaluate approximately 300 pregnant women and their newborns. Number of daily cigarettes smoked, time of last smoking and newborn status are registered, but these variables were not considered until now due to sample size. In this study, urinary 1-OHP was unable to indicate significant higher exposure to PAH in smoking mothers. In order to better evaluate intrauterine exposure to PAH, a bigger sample, pattern of smoking and newborn status and biological samples must be considered. This work was financially supported by FAPERGS.

Keywords: Tobacco, Pregnancy, 1-Hydroxypyrene

Imidazole Cyclodextrin (ImCD) as an Antidote for Cyanide Poisoning: In Vitro and In Vivo Results

Takeshi Yamagiwa^{*1}, Takeshi Saito¹, Akira T. Kawaguchi², Kenji Watanabe³, Hiroaki Kitagishi³, Koji Kano³, and Sadaki Inokuchi¹

¹The Department of Emergency and Critical Care Medicine, Tokai University School of Medicine, Japan; ²Cell Transplantation and Regenerative Medicine, Tokai University School of Medicine, Japan; ³Department of Molecular Chemistry and Biochemistry, Doshisha University, Japan

Objectives: Acute cyanide poisoning has attracted attention as one of the possible causes of death during home fires. Imidazole Cyclodextrin (ImCD), a synthetic supermolecular complex with an extremely high affinity to the cyanide anion was synthesized. ImCD may act as an antidote preventing inhibition of cytochrome-c oxidase. The purpose of this study is to evaluate the effect of ImCD against cyanide poisoning of cell cultures and mice.

Methods: In vitro: Murine 3T3 fibroblasts were incubated for 4 hours in alpha-modified minimum essential medium (α MEM) containing 20% fetal bovine serum (FBS) (MEM group), α MEM and 5 mM potassium cyanide (KCN) (KCN group), or various doses of ImCD (0.6 - 5.0 mM) and 5 mM KCN (ImCD group). The pH levels of all solutions were adjusted to 9.2 based on the pKa of KCN. The viability of fibroblasts was determined by the activity of cytochrome-c oxidase using a colorimetric enzyme activity assay (MTT).

In vivo: Two-day survival rate was defined in BALB/c mice, pretreated with intravenous ImCD (0.23mmol/kg, equi-molar to KCN) or intravenous saline, receiving KCN (15mg/kg) by oral gavage; the two groups consisted of 7 mice each.

Results: In vitro: The Optical Density value of 3T3 fibroblasts in the MTT assay was significantly higher ($p < 0.001$) in the ImCD group (0.379 ± 0.010) than KCN group (0.027 ± 0.014), which was not significantly different ($p > 0.05$) compared with the MEM group (0.380 ± 0.014). Furthermore, a dose-dependent antagonistic effect of the ImCD was demonstrated in vitro.

In vivo: The mortality rate of the ImCD-treated mice (1/7, 14.3%) was lower than that of saline-treated mice (7/7, 100%).

Conclusions: The results suggest that ImCD has a potent antagonistic effect against the cytotoxicity of cyanide compounds. A dose-dependent antagonistic effect was shown in the cell culture poisonings and improved survival rate was seen in orally poisoned mice.

Key Words: Imidazole Cyclodextrin, Cyanide Poisoning, Antidote

Methadone and Metabolites in Hair of Methadone-Maintained Pregnant Women and Their Infants

Sarah K. Himes*¹, Robert S. Goodwin¹, Colleen M. Rock², Hendrée E. Jones³, Rolley E. Johnson⁴, Diana G. Wilkins² and Marilyn A. Huestis¹

¹Chemistry and Drug Metabolism, IRP, NIDA, NIH, Baltimore, MD, USA; ²Center for Human Toxicology, University of Utah, Salt Lake City, UT, USA; ³RTI International, Research Triangle Park, NC, USA; ⁴Department of Psychiatry and Behavioral Sciences, Johns Hopkins University School of Medicine, Baltimore, MD, USA

Funded by grants DA R01 12220 and DA 12403 from NIDA and M01RR-02719 from the GCRC of the NCRR, NIH and by the National Institutes of Health, IRP, NIDA.

Objective: Methadone (MTD) is the recommended pharmacotherapy for US opioid-dependent pregnant women. Through sequential N-demethylation, MTD is metabolized to 2-ethylidine-1,5-dimethyl-3,3-diphenylpyrrolidine (EDDP) and 2-ethyl-5-methyl-3,3-diphenylpyrroline (EMDP). The primary goals of this study were to determine whether a dose-concentration relationship exists between cumulative maternal MTD dose and MTD, EDDP and EMDP concentrations in maternal hair during pregnancy and whether maternal hair concentrations predict neonatal outcomes. Methadone pharmacotherapy in pregnant women provided the rare opportunity to examine controlled drug incorporation in hair in the maternal and fetal dyad.

Methods: Hair specimens were collected monthly from 29 opioid-dependent mothers enrolled in methadone treatment. Hair also was collected from 4 infants within 3 days of birth. Hair specimens were segmented (3 cm each), washed (maternal hair only) and analyzed for the presence of MTD, EDDP and EMDP by LCMSMS. If there was sufficient quantity, hair was analyzed washed and unwashed. Factors influencing dose-concentration relationships were assessed, including delay in drug incorporation in hair due to time required for drug from the hair root to reach the scalp, variable hair growth rates, and hair left near the scalp when sampling.

Results: No dose-concentration relationship was observed between cumulative MTD dose and MTD, EDDP or EMDP concentrations in hair, even when isolating hair specimens corresponding to the third trimester. However, large variability between subjects was noted. A significant positive linear relationship was shown for cumulative MTD dose and EDDP/MTD ratio, perhaps reflecting MTD induction of its own metabolism. Within individuals, however, positive trends were seen between cumulative MTD dose and MTD and EDDP concentrations in hair. EMDP was only occasionally found, mainly in specimens with MTD concentrations above the upper limit of quantification (50 ng/mg). Concentrations in washed hair were not significantly different from unwashed levels. Distal segments had lower concentrations of analytes than proximal segments. Comparisons between infant and maternal hair concentrations (n=4) showed that maternal MTD hair concentrations were significantly higher than those in infant hair, although infant EDDP hair concentrations were significantly higher than in maternal hair. Maternal MTD and EDDP hair concentrations were not correlated with infant neonatal abstinence syndrome (NAS) score at birth, peak NAS score, days until peak NAS score, birth length or head circumference. Maternal cumulative MTD dose, MTD and EDDP hair concentrations, neonatal birth length and head circumference were not correlated with peak NAS score or the amount of morphine pharmacotherapy for infants (n=7).

Conclusions: It is unclear from this study that a dose-concentration relationship exists for MTD in pregnant women's hair or that there is predictive value of maternal dose and hair concentrations on neonatal outcomes.

Key Words: Methadone, Hair, Pregnancy

Validation of a Solid Phase Extraction Procedure for Identification and Quantification of Cocaine, Metabolites and Derivatives in Meconium Using GCMS

Marcela Nogueira Rabelo Alves^{*1} and Bruno Spinosa De Martinis²

¹Faculty of Pharmaceutical Sciences of Ribeirão Preto, Ribeirão Preto, SP, Brazil; ²Faculty of Philosophy, Sciences and Literature of Ribeirão Preto. Ribeirão Preto, SP, Brazil

Objective: The purpose of the work was to develop and validate a method for the analysis of cocaine, benzoylecgonine, cocaethylene and anhydroecgonine methyl ester in meconium samples using solid phase extraction and GCMS techniques for application at a public hospital in Ribeirão Preto, Brazil.

Materials and Methods: The analytes were initially extracted from the matrix with methanol. Then, a solid-phase extraction with Bond Elut Certify I cartridges was performed. The cartridges were washed with water and 0.1M hydrochloric acid and the samples were eluted with a mixture of 80:20:2 dichloromethane/isopropanol/ammonium hydroxide. The extracts were dried and derivatized with BSTFA/TMCS (99:1). Analytes were determined in a GCMS *ion trap, full scan* mode. The method was validated in the range of 20-1000 ng/g for cocaine and cocaethylene; 40-1500 ng/g for benzoylecgonine and 60-1500 ng/g for anhydroecgonine methyl ester, using 0.5 g of meconium per assay. The detector response was linear in the studied range and limits of detection were found to be 10 ng/g for cocaine and cocaethylene, 30 ng/g for benzoylecgonine and 40 ng/g for anhydroecgonine methyl ester. Intra-batch coefficients of variation were in the range of 3.01% and 10.15% and inter-batch between 5.31% and 11.12%; accuracy was in range 91.47% - 105.31%.

Results and Conclusions: The recoveries were higher than 56.30%. Interferents were chosen based on structural similarity with the investigated analytes or in substances with high consumption rate during pregnancy. Acceptable selectivity was determined for the following interferents: acetylsalicylic acid, alprazolam, amphetamine, caffeine, dipyrone, ephedrine, phenylephrine, fluoxetine, metoclopramide, nicotine, iron sulfate and tetrahydrocannabinol. The validated method was applied to meconium samples collected from 20 newborns in the Clinical Hospital from the Medicine School of Ribeirão Preto, São Paulo, Brazil. Samples were collected from babies' diapers whose mothers had high risk gestation. Previously, the mothers answered a self-report about use of drugs. Among the 20 samples collected, 11 mothers reported cocaine use at least once in their entire lives and 9 mothers denied cocaine use. In the first group, 3 positive samples for cocaine, benzoylecgonine and anhydroecgonine methyl ester were detected and from the second group, another 3 samples were positive for cocaine and benzoylecgonine, indicating drug consumption during pregnancy. No positive sample for cocaethylene was detected in accordance with the mothers' self report answers. These data confirmed method sensitivity and efficiency for detecting cocaine, benzoylecgonine, cocaethylene and anhydroecgonine methyl ester in meconium samples.

Key Words: Cocaine, Meconium, GC-MS

Mistreatment of Older People in a Retirement Home: Evidence of Chemical Abuse Through Hair Analysis**Veronique Dumestre-Toulet***, Fabienne Laborie Charvier and Alain Eyquem

Laboratoire TOXGEN, Bordeaux, France

Introduction: Mental abuse and neglect of elderly are frequently described. Other mistreatments include physical abuse, assault, pushing or use of restraints (bed, furniture). Nevertheless, this seems to be an underestimated phenomenon and very little information is available about chemical abuse of the elderly. During an investigation involving an alleged mistreatment in a retirement home, a judge asked our laboratory to document drug exposure for the last months in 15 elderly women (age range 80-96 years). In compliance, we conducted hair analysis to test for sedatives and hypnotics.

Objectives: An assay, based on LC-MS/MS, was developed for the simultaneous screening of meprobamate, paroxetine, cyamemazine, alimemazine, tiapride, mianserin, haloperidol, carbamazepine, clobazam, bromazepam, lorazepam, zopiclone, zolpidem, nordiazepam, and oxazepam.

Materials and Methods: According to the literature (1), hair strands were twice decontaminated with methylene chloride, dried and segmented. Lack of external contamination was verified by analysing the last wash solution. Each segment was cut into small pieces and about 20 mg were incubated for 2 hours in Sorensen buffer (pH 7.4) in the presence of deuterated internal standards (meprobamate-d7, paroxetine-d6, haloperidol-d4, Zolpidem-d6, diazepam-d5, 7-aminoclonazepam-d4). After solid phase extraction on Oasis HLB cartridges (Waters) and evaporation to dryness, the residue was reconstituted in the mobile phase (2 mM formate buffer and acetonitrile). Analysis was performed using an XTerra MS C18 column and detection was achieved with an atmospheric pressure ionization tandem mass spectrometer (two daughter ions for each compound).

Results: The limit of quantification (LOQ) for all compounds ranged from 5 to 20 pg/mg using a 20-mg hair sample. The method was linear for each compound from the LOQ to 500 pg/mg. Imprecisions and inaccuracies, at 10 and 50 pg/mg, were better than 30% in all cases. The extraction recovery, measured at the same two concentrations, ranged from 32 to 76%, which was considered suitable for a screening procedure.

White (6 subjects), coloured (5 subjects) and pigmented gray (4 subjects) hair strands, were analysed. Meprobamate was identified in 14 cases (89 pg/mg to 50 ng/mg), zolpidem in 6 cases (6.8 pg/mg to 2 ng/mg), oxazepam in 4 cases (26 to 153 pg/mg), mianserin in 3 cases (227 to 528 pg/mg), paroxetine in 2 cases (18 to 568 pg/mg), haloperidol in 2 cases (5 to 31 pg/mg), and cyamemazine was identified in 2 cases (28 to 189 pg/mg). In some cases, multisectional analysis documented long term exposure for the subjects. We have considered that high concentrations were due to different hair colours and primarily to different drug dosages. Police investigations revealed that some of these pharmaceuticals were not prescribed to the subjects and not given by the family.

Conclusion: Numerous sedatives were identified in the hair collected from the elderly people, and hair analysis documented repeated exposures. Even if it is difficult to put a quantitative interpretation on the dosage from the measured concentrations, hair analysis appears as a useful complement for investigations.

References:

1. Villain M *et al* - J Chromatogr B Analyt Technol Biomed Life Sci. 2005;825:72-8.

Key Words: Elderly Mistreatment, Hair Analysis, Pharmaceutical Drugs

Case Report of THC Identified in Pubic Hair Documenting Drug Use by a Public Authority Official

F.Aknouche*, E.Guibert, R. Buti, and M. Eyraud
Laboratoire BioMed, Antibes, France

Objective: To detect THC in pubic hair as a substitute for head hair analysis of drugs.

Case Report: Arrested in drug trafficking, a dealer filed a complaint against a partner for a payment default. An investigation ensued and pointed to involvement of a judicial authority. The accused's partner was a person of public authority. The judicial inquiry revealed several offenses for this person: robbery, breaking and entering, and diversion of seals. The objective was to determine if the suspected public official used illegal drugs. Blood, urine and pubic hair were collected for analysis; no head hair was available.

Method: Biological samples (blood and urine) were extracted using a liquid-liquid extraction with Hexane/Ethyl Acetate (v/v 80/20) for the detection of Delta-9-Tetrahydrocannabinol (THC) and a second liquid-liquid extraction with Chloroform/Isopropanol (v/v 95/5) for other drugs. The extracts were dried and derivatized with BSTFA (TMS). Pubic hairs were decontaminated by two successive baths of methylenchloride, dried and then cut into small segments of a few millimeters. Hair segments were subjected to both acid and base hydrolysis. Acid hydrolysis utilized 0.1 N HCl overnight at 56°C. Basic hydrolysis was performed using 10N NaOH for 15 minutes at 56°C. Hydrolysis was followed by extraction with 1-chlorobutane and derivatization with BSTFA (TMS). All derivatized extracts were analyzed by gas chromatography mass spectrometry (Focus GC equipped with a column TR5MS, Polaris Q ion trap X Calibur software).

Results: No traces of any drugs were detected in the blood and urine. Pubic hair analysis revealed only the presence of THC at 46 pg/mg.

Conclusion: The presence of THC in pubic hair indicates the consumption of marijuana. With hair analysis, it is possible to demonstrate the presence of many drugs and narcotic substances. The advantage of hair as a biological matrix is that it has a long window of detection (months-years). In this case, the pubic hair analysis provided the evidence necessary to apprehend this person for transportation and possession of drugs and the unauthorized use of narcotics.

Key Words: Delta-9-Tetrahydrocannabinol, Pubic Hair

Comparison Study of Oratect® Oral Fluid Drug Screen Devices for Amphetamine, Cocaine, Opiates, Methamphetamine, THC and PCP with LC/MS/MS Confirmation

Huiying Wang*, Raphael C Wong, Jim KK Tung, Chau Tran, Wen Li, Anh Le, Phung Nguyen and Beckie Wong
Branan Medical Corporation, Irvine, CA, USA

Introduction: The use of oral fluid as an alternative matrix for detection of drugs of abuse has continually increased over the last decades due to its ease of collection. The Oratect® Oral Fluid Drug Screen Device is a rapid, one-step lateral flow immunoassay device for the qualitative detection of d-Methamphetamine, Delta-9-Tetrahydrocannabinol, Cocaine, Opiates, Amphetamine and PCP in human oral fluid at the cut-off concentrations listed below (see Table 1). The collection of oral fluid takes about 1-4 minutes, and the test starts to run when the collection pad is saturated and finishes in 5 minutes (A blue line indicator shows adequate amount of sample collected).

Objectives: The objective of this study was to evaluate the accuracy of Oratect® Oral Fluid Drug Screen Devices with real saliva samples which were analyzed by a LC/MS/MS in a reference lab.

Materials and Methods: For each Oratect® assay, forty true negative samples and a minimum of forty samples containing different concentrations of analytes were tested.

Results: Sensitivity, specificity and accuracy were calculated by comparison of the Oratect results to the LC/MS/MS results at their respective cutoff concentrations.

Table 1. Accuracy Summary of Oratect® Oral Fluid Drug Screen Devices

	Opiates	Amphetamine	Methamphetamine	Cannabis	Cocaine	Phencyclidine
Cutoff ng/mL	40 ng/mL	50 ng/mL	50 ng/mL	40 ng/mL	20 ng/mL	10 ng/mL
TP (True Positive)	31	21	34	32	27	34
FP (False Positive)	1	0	1	2	0	0
TN (True Negative)	47	68	46	54	51	44
FN (False Negative)	1	1	1	2	2	2
Sensitivity TP/(TP+FN)	96.9%	95.4%	97.1%	94.1%	93.1%	94.4%
Specificity TN/(TN+FP)	97.9%	100%	97.9%	96.4%	100%	100%
Accuracy	97.5%	98.8%	97.6%	95.5%	97.5%	97.5%

Conclusion: It was concluded that Oratect® Oral Fluid Drug Screen Device for the qualitative detection of d- Amphetamine, d- Methamphetamine, Delta-9-Tetrahydrocannabinol, Cocaine, Opiates, and PCP in oral fluid is highly sensitive and specific, and the results agree well with mass spectrometric analysis.

Keywords: Oral Fluid, Cocaine, Opiates, Amphetamine, Methamphetamine, THC, PCP

Evaluation of On-Site Oral Fluid Drug Screening Devices

Ulrich Bott*¹, Eva Grosse Hokamp², and Frank Musshoff²

¹North Rhine - Westphalia Police Force Central Support Services Bureau, Duisburg, Germany; ²Institute of Forensic Medicine, University Hospital, Bonn, Germany

Introduction: There is a need for quick and reliable methods for rapid screening of drugged drivers on the roadside by police. Because the window of detection in oral fluid is more similar to blood than to urine, this matrix should be appropriate for screening procedures.

Materials and Methods: The performance of the RapidSTAT (Mavand Solution GmbH, Mössingen, Germany), DrugWipe 5/5+ (Securetec Detektions-Systeme AG, Brunnthal, Germany) and Dräger DrugTest 5000 (Draeger Safety AG&Co. KGaA, Luebeck, Germany) on-site oral fluid devices were evaluated with random oral fluid specimens from drivers in North Rhine-Westphalia (Germany). The cut-offs proposed by the manufacturers are shown (Table 1). In a 6 month period, 1212 drugged drivers were tested. The officers used the Dräger DrugTest (n=530), RapidSTAT (n=234) cases, and DrugWipe (n=47). Test results obtained by the police were compared with quantitative data from blood samples taken from these suspected drivers. Cut-offs were set according to the German legal guidelines, with benzodiazepines at 10 ng/mL. The results of the oral fluid devices also were compared with results of a urine device (DrugScreen, NAL von Minden) and sensitivities and specificities were compared with the literature.

	Draeger DrugTest	RapidSTAT	DrugWipe 5/5+
THC	5	5	30
Opiates	20	10	10
Amphetamines	50	25	50
Methamphetamine	35	25	25
Benzodiazepines	15	25	10
Cocaine	20	10	15

Results: The following sensitivities (TP/(TP+FN)) were obtained by the oral fluid devices: THC 71% (DrugWipe), 87% (Dräger), 91% (RapidSTAT); opiates 95% (Dräger), 100% (DrugWipe, RapidSTAT); amphetamine 84% (Dräger), 90% (RapidSTAT), 100% (DrugWipe); methamphetamine 50% (Dräger), 100% (RapidSTAT); cocaine 76% (Dräger), 100% (DrugWipe, RapidSTAT); methadone 33- 63% , and benzodiazepines 0-33% (both with low number of positives). THC specificity (TN/(TN+FN)) was especially low (29% [DrugWipe] and 47% [Dräger]) due to low cut-off concentrations. These data were similar to those from literature (e.g. DRUID project). The urine screening device showed good sensitivity (THC 93%, opiate 94%, amphetamine 94%, methamphetamine 75% (low number of positives), cocaine 100%) and useful specificity (39%, 86%, 63%, 77%, 47%, respectively).

Conclusion: Although oral fluid may be a useful matrix for on-site testing of drugged drivers, it is evident that oral fluid devices still have a lack of sensitivity (methamphetamine, benzodiazepines) and specificity (THC). Poor results for benzodiazepines can be explained by the small positive test number. Although the sensitivity for THC is higher compared to literature, the specificity is not yet satisfactory (>95 %). Furthermore, specificity was poor due to low cut-offs, which resulted in multiple false-positive tests.

Key Words: Oral Fluid, Immunoassay, Driving Under the Influence

Percentages of N- and O-Demethyl Metabolites of Tramadol in Hair – Use for Assessment of Tramadol Intake vs. External Contamination

Milena M. Madry*¹, Kristina Y. Rust¹, Ulfert Grimm², Markus R. Baumgartner¹ and Thomas Kraemer¹

¹Institute of Forensic Medicine, University of Zurich, Zurich, Switzerland; ²Institute of Legal Medicine, St. Gallen, Switzerland

Objectives: Tramadol was found in a hair sample within the context of abstinence control to regain a driving license. The individual denied having taken tramadol. He claimed that external contamination must be the reason for the positive result, because he was working in a tramadol production company. Detection of tramadol metabolites should prove the actual intake of tramadol. However, only low concentrations of both metabolites could be found in hair. In order to assess the results in this case, the ratios of N- and O-demethyltramadol vs. the parent compound in other routine tramadol cases as well as in hair of other employees working in the same company could be assessed.

Methods: N- and O-demethyl metabolites of tramadol together with the parent drug were determined in hair of 75 tramadol positive cases after washing and a two step extraction procedure (methanol and methanol/ hydrochloric acid) of hair. The analytes were separated and detected using a DIONEX LC-system coupled to an AB Sciex 5500 QTRAP. Separation column, mobile phase and MS mode were: Phenomenex Kinetex-C₁₈ 2.6 µm, 50/2.1; 5mM ammonium formate buffer pH3/ methanol with ammonium formate, total flow of 0.5-0.6 ml/min; ESI, MRM-IDA-EPI.

Results:

	Tramadol concentrations (pg/ mg)	Percentages ODMT/ tramadol (%)	Percentages NDMT/ tramadol (%)
Patients (n= 75)	40 – 160,000; Median: 650	0.7 – 43; Median: 11.5	2.8 - 96.7; Median: 17.7
Employees (n= 8)	5 – 650; Median: 49	0.4 – 1.6; Median: 0.8	1.8 – 11.3; Median: 3.4
Case	2400	1.3	10.4

ODMT= O-demethyltramadol; NDMT= N-demethyltramadol

Very large interindividual differences in the metabolite vs. parent drug ratios in hair were observed for tramadol. In interpreting these results, it must be considered that the O-demethyl metabolite is formed via the polymorphically expressed CYP2D6. Poor metabolizers for this isoenzyme may produce the O-demethyl metabolite to a lesser extent, as in the suspect case. On the other hand, CYP3A4 overexpression may lead to a higher percentage for the N-demethyl metabolite.

Conclusion: Percentages for both the N-demethyl and O-demethyl metabolite were different by comparison of the two groups (patients vs. employees). Differentiation of contamination from consumption may be possible in some cases.

Key Words: Tramadol; Metabolites; Hair Analysis

Effect of Reducing the Cut-Off Concentration for Opioids in Oral Fluid Screening

Margaux Garnier*, Cynthia Coulter and Christine Moore
 Immunoanalysis Corporation, Pomona, CA, USA

Introduction: Opiate and oxycodone ELISA screening data from oral fluid samples received into our laboratory were reexamined. Samples that fell between the cut-off concentration (40ug/L) and the low positive control (20ug/L) were extracted and analyzed for codeine (COD), morphine (MOR), hydrocodone (HYC), hydromorphone (HYM), oxycodone (OXYC), oxymorphone (OXYM), 6-acetylcodeine (6-AC), and 6-acetylmorphine (6-AM) using LC-MS/MS.

Objective: To analyze these previously screened negative samples in order to indicate the number that may confirm positively for opioids if the cut-off concentrations for both screening and confirmation were reduced.

Methods: Data from opiate and oxycodone ELISA screens from oral fluid samples were retrospectively analyzed. Specimens that screened between the cut-off concentration and the low positive control (LPC) were noted and were analyzed using LC-MS/MS. Specimens which confirmed > 4ug/L were considered positive.

Results: Of all the opioids analyzed, morphine had the highest percentage increase in positive results of 50%. Four more samples confirmed for codeine, ranging between 11.9 and 33.0ug/L, increasing its positivity rate to 36.3%. Twenty samples were positive for hydrocodone which displayed a rise of 27.4%. Oxycodone showed the least increase with nine samples confirming positively and a 16.0% increase. Analyzing specimens below the 20ug/L concentration resulted in six more oral fluid specimens being identified for 6-AM as well as more positives for codeine and morphine.

Conclusion: Since oral fluid serves as a good matrix in identifying users of pain management drugs, it is imperative that we use this to our advantage in distinguishing users from non-users. If the cut-off is too high, it may produce false negative results. A reduction in the cut-off concentration for both screening (from 40ug/L to 20ug/L) and confirmation of opioids in oral fluid should be considered to increase the number of opioid positives.

	HYC	OXYC	COD	6-AM	MOR	HYM	Total # Opioid Positives
Oral fluid data (x ≥ Cut-off)	73	56	11	10	4	2	156
LPC ≤ x ≤ Cut-off	20	9	4	0	2	0	35
% increase	27.4	16.0	36.3	0.0	50.0	0.0	22.4

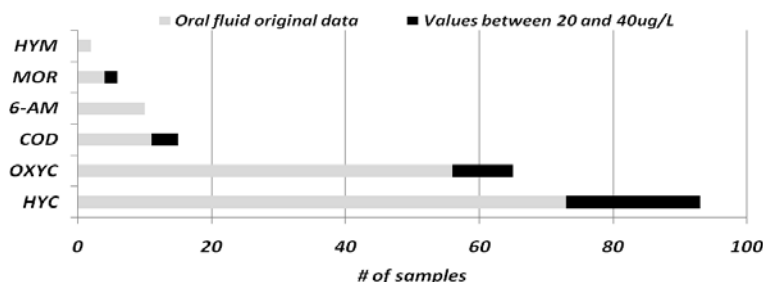

Key Words: Oral Fluid, Opioids, ELISA

Quality Control in Hair Analysis: The Society of Hair Testing Experience

Carmen Jurado*¹, Pascal Kintz², and Hans Sachs³.

¹Instituto Nacional de Toxicología y Ciencias Forenses, Sevilla, Spain; ²X-Pertise Consulting, Oberhausbergen, France;

³Forensisch Toxikologisches Centrum, Munich, Germany

Objective: Since the Society of Hair Testing (SoHT) started in 1995, proficiency tests (PT) have been implemented and organized within their activities. In the beginning, these PT were sporadically organized however, since 2001 they have been organized annually. This study has two main objectives: to evaluate the performance of participating labs by analyzing qualitative and quantitative results from the different rounds of PT, and to determine the accuracy of the labs when analyzing the same sample in a blind trial.

Material and Methods: Sets of five samples were distributed among the participants in each round. Samples sent to the participating laboratories included, a drug-free hair sample obtained from a drug abstaining individual, and others, which were positive for different drugs of abuse and were obtained from drug users. They were sent in the form of short (1-2 mm) segments. Concentrations and homogeneity were previously verified by three reference laboratories. Participant labs performed analyses for opiate, cocaine, cannabis and amphetamine compounds and provided their analytical procedures.

Results: The number of participating laboratories ranged from 18 in 2001 to 28 in 2009. Results were evaluated qualitatively and quantitatively. Qualitative evaluation was performed by calculating sensitivity and specificity. Sensitivity ranged from 94% in 2004 to 100% in 2009. Specificity ranged from 93-100% over the years with all but two PT evaluations achieving 100%. Quantitative results were scattered. Z-scores were used to investigate quantitative performance. The majority of the laboratories reported satisfactory results, with Z-score values within a ± 2 range. Concentrations reported by 4.78 % of the participants were questionable ($2 < Z\text{-score} \leq 3$). Only 1.06 % of the labs reported unsatisfactory results with Z-scores > 3 . With respect to the accuracy of the laboratories when analyzing the same sample, a correct identification was considered to occur when concentrations reported for the different analytes differed by less than 15%. Only 6 laboratories out of 21 reported results with percent error ≥ 15 , thus failing to identify the same sample.

Conclusions: From the evaluation of these proficiency tests, we can conclude: 1) selectivity was $\geq 94\%$ and specificity was 100% for most PTs; 2) with respect to quantitative results, 94.16 % of the laboratories reported satisfactory results, based on Z-score values; and 3) the majority of the labs (71.43%) successfully identified the same sample.

Key Words: Proficiency Test, Hair Analysis, Drugs of Abuse, Society of Hair Testing

GC-MS Analysis of Hair for the Detection of Drugs of Abuse and Their Metabolites

Georgios Psaros¹, Alexia Koukou¹, Amvrosios Orfanidis¹, Orthodoxia Mastrogianni², Georgios Theodoridis¹, Heleni Zagelidou², Heleni Tsoukali-Papadopoulou³ and **Nikolaos Raikos**^{*3}

¹Department of Chemistry, Aristotle University, Thessaloniki, Greece; ²Laboratory of Forensic Service of Ministry of Justice of Thessaloniki, Greece; ³Laboratory of Forensic Medicine and Toxicology, Medical School, Aristotle University, Thessaloniki, Greece

Objectives: Hair analysis is recognized as a suitable method for the assessment of long term use of drugs of abuse. In the present paper we describe the development of a new methodology aiming to detect and quantify the presence of drugs of abuse of three major categories in hair from human subjects including samples of narcotic drug users.

Materials and Methods: Hairs were obtained from drug-free humans and were used for method development: All hair samples were washed with water, followed by acetone and finally with dichloromethane. Thirty mg of washed hairs were spiked with the analytes of interest and internal standards, and the sample was subsequently extracted with methanol. Following centrifugation, the extract was evaporated to dryness and BSTFA (1%TMCS) was added to the dry residue. Following derivatisation, analysis was conducted on GC-MS with selected ion monitoring (SIM). The analytes included: 6-monoacetylmorphine, morphine, codeine, cocaine, benzoylecgonine, ecgonine methyl ester, amphetamine, methamphetamine, MDA, MDMA. Internal standards from each category were added (in total three standards).

Results: First the GC-MS (electron impact) analytical method was optimized to reach the best chromatographic separation and highest sensitivity. Three ions were selected for each analyte for SIM and one of these three ions was used for quantitation. Next, the methodology applied for the derivatisation was optimized: derivatisation time, temperature and volume of BSTFA added were studied. The best conditions were 20 min, 70 °C and 50 µL of BSTFA respectively. Using the developed methodology, calibration curves were obtained for the 10 analytes (8 concentration points and four independent repetitions for each point). Linearity was found satisfactory (R^2 ranged from 0.972 to 0.999). Within day repeatability (RSD less than 15%) was found very satisfactory. Stability of the derivatised sample was found limited to 48 hours. The limit of detection was found in the low ng/mg range (varying from 0.2 to 0.5 ng/mg of hairs). The method was successfully applied to the analysis of samples from drug users.

Conclusion: A simple and efficient method was developed and validated for the detection and quantitation of drugs of abuse and their metabolites in trace levels in hair. This tool is complementary to the existing arsenal of analytical tools in the fight against drug abuse, increasing the time span for the detection of drugs of abuse in biological samples.

Keywords: Hair Analysis, Drugs of Abuse, GC-MS

Validation of a Simplified GC-MS Procedure for Confirmation of Oral Fluid On-Site Immunoassay Tests in a Program of Roadside Toxicological Screening of Drivers

Jennifer P. Pascali^{*1}, Matteo Morelli¹, Sabina Strano-Rossi², Giovanni Serpelloni³, Roberto Mollica³, Marcello Chiarotti² and Franco Tagliaro¹.

¹Section of Forensic Medicine, Dept. of Public Health and Community Medicine, University of Verona, Italy; ²Institute of Legal Medicine, Catholic University Rome, Italy; ³Antidrug Policies Department, Rome, Italy

Objectives: The present work was performed as part of a project of the Department of Antidrug Policies, Presidency of the Italian Council of Ministers, aimed at the evaluation of the analytical screening performances of on-site Oral Fluid (OF) commercial devices. The focus was development and validation of a simple GC-MS method to be used as a confirmation technique on the presumptively “positive” samples, previously identified by different on-site oral fluid immunoassays. The accuracy of the developed technique was tested by comparison of the results with a validated UHPLC-QQQ MS method.

Materials and Methods: Saliva samples were collected on-site during roadside controls by Police officers, who also carried out a screening immunoassay aimed at the qualitative identification of amphetamine and congeners, opiates, cocaine and metabolites and cannabinoids. The GC-MS procedure was optimized for amphetamine, methamphetamine, MDA, MDMA, MDEA, MBDB, morphine, O-6-MAM, codeine, cocaine, methadone, benzoylecgonine, cocaethylene, Δ 9-THC and ketamine. One mL of saliva sample with added internal standard (nalorphine), was extracted in SPE (Bond Elut Certify, Agilent) followed by a MSTFA derivatization step prior GC-MS analysis. The method sensitivity was tested at a 20 ng/mL level for each compound, with the objective of minimizing the sample volume needed.

Results and Conclusion: GC-MS results were compared with those from a “direct injection” UHPLC-MS/MS method developed and carried out at the Institute of Legal Medicine of the Catholic University in Rome. Cocaine and its metabolites benzoylecgonine and cocaethylene were the class of substances mainly found by both methods, followed by Δ 9-THC. Discrepancies between the results from the two methods were found only in 12% of the samples for the following class of substances: THC, benzoylecgonine and MDMA. Such discrepancies were found mainly when the remainder of saliva after HPLC-MS/MS used for GC-MS was less than 300 μ L, particularly for amphetamines (because of an inherent lack of sensitivity of GC-MS).

A comparison of the data from the GC-MS confirmation analyses and the data from the on-site tests showed an 18% discrepancy in qualitative results, mainly due to on-site positivity not confirmed by GC-MS.

Key Words: GC-MS, Saliva, Toxicological Screening

Evaluation of Different Hair Color and Ethnicity Types Following Surface Contamination with Cocaine and Laboratory Decontamination

Nichole Bynum*, Cynthia Lewallen, Jeri Roper-Miller, Peter Stout, Jordan Espenshade, John Mitchell and Michael R. Baylor.

RTI International, Research Triangle Park, NC, USA

Objectives: The mechanism(s) of permeability of hair to drugs are not fully understood. Variations in drug absorption between hairs of different hair color and ethnicities are cause for changes in policies regarding hair drug testing. Research data suggests that hair color may affect cocaine's incorporation into and retention in the hair matrix. The possibility that because of hair color one individual may be more likely to test positive for a drug than another greatly concerns policymakers and forensic practitioners. The potential for such bias must be understood to ensure the correct interpretation of results and the appropriate use of hair testing. The goal of this study was to evaluate cocaine analytes in hair of different color (e.g., light, dark) and ethnic origin (e.g., Caucasian, African American [AA]) after the hair has been subjected to surface contamination with cocaine and subsequent laboratory decontamination.

Materials and Methods: Hairs (Caucasian light and dark hair types, AA; n=12 each) were contaminated with cocaine (COC) HCl powder (98.9% pure) and the structural differences between the hairs of the different ethnicities were visually examined by a variety of microscopy techniques before and after contamination and washing. The *in vitro* surface contamination study design was modified, but generally followed a previously published method by Stout et al. (2006). Briefly, the verified drug-free head hair samples were collected under IRB protocol, contaminated with cocaine HCl powder, shampooed daily for 8 weeks with aliquots removed weekly for decontamination (two washing protocols: methanol and extensive phosphate buffer) and analyzed for COC analytes by LC/MS/MS. Quantitative analytical procedures for the determination of COC, benzoylecgonine (BE), cocaethylene (CE), and norcocaine (NCOC) in hair were performed on an Agilent Technologies (Santa Clara, CA) 1200 Series liquid chromatography system coupled to a 6410 triple quadrupole mass spectrometer, using positive ESI mode. For confirmation, two transitions were monitored and one ion ratio was determined which was acceptable if within 20% of the ratio of known calibration standards.

Results: While our previous COC surface contamination studies were designed to provide an estimate of inter-individual variation, this study included sufficient samples to determine differences between ethnic groups or hair color with statistical significance. These data suggest there was no apparent simple relationship between concentration and hair color by this *in vitro* COC surface contamination model. The limits of quantitation were 25 pg/mg COC and 2.5 pg/mg for BE, CE, and NCOC. The upper limit of linearity was 55,000 pg/mg for COC and 1,000 pg/mg for all other analytes. Between-run imprecision was <3% for COC at 150 pg/mg and <8% at 15 pg/mg for other analytes. Methanolic decontamination was not very effective at removing COC analytes from the surface of the hair following this *in vitro* contamination model. In contrast, the extended phosphate decontamination resulted in significantly lower concentrations of all targets.

Conclusions: The results suggest that while COC analyte concentrations may be significantly higher in dark hair types, including AA individuals, use of BE/COC ratios and extensive decontamination wash criteria greatly reduce positive hair testing results in this *in vitro* surface contamination model. Potential criteria to evaluate the decontamination solutions in relation to the hair concentrations may be necessary unless the presence of other unique COC metabolites in hair can be reliably established. These findings could have a significant impact on whether national agencies use hair testing.

Key Words: Hair, Cocaine Analytes, LC/MS/MS

Simultaneous Application of the Cozart® DDS801 and DrugWipe® 5⁺ Oral Fluid Screening Devices in an Experimental Procedure for Roadside Drug Testing

V. Pirro^{1,2}, A. Salomone^{*1}, S. Pellegrino¹ and M. Vincenti^{1,2}

¹Centro Regionale Antidoping e di Tossicologia "A. Bertinaria", Orbassano, Turin, Italy; ²Dipartimento di Chimica Analitica, Università degli Studi di Torino, Turin, Italy

Objectives: Oral fluid is increasingly used as the biological matrix of choice in roadside drug testing. Collection of oral fluid is noninvasive, rapid, simple and can be carried out by the driver himself under supervision. To improve the efficiency and applicability of roadside drug testing, it is necessary to use simple, rapid and reliable oral fluid screening devices and adopt an experimental procedure in which screening, evaluation of driving impairment and sample collection for confirmatory analyses take place within the same short timeframe.

Materials and Methods: Between December 2010 and February 2011, the local Police of Turin organized a series of periodic roadside drug tests. The aim of the study was to apply an experimental procedure in which the DrugWipe® 5⁺ (Securetec Detektions-Systeme, Munich, Germany) and the Cozart® DDS801 (Concateno, Abingdon, UK) portable devices could be simultaneously used for oral fluid drug screening and the results immediately compared. In cases of positive testing, medical personnel from the Italian Red Cross ascertained the occurrence of driving impairment through objective examination and collected the biological samples (an unstimulated oral fluid sample and urine) for confirmatory analyses. Samples were sealed and initialled by the medical personnel. The chain of custody was secured when samples were sent to the toxicology laboratory for confirmatory analyses. Both urine and oral fluid samples were tested for Δ^9 -THC, cocaine, morphine, codeine, 6-MAM, methadone, ketamine, amphetamine and methamphetamine by GC-MS operating in SIM mode.

Results: A total of 397 drivers were subjected to roadside drug testing. Out of 397, 364 subjects (91.7%) resulted in negative tests. Based on symptoms and/or oral fluid test results, 33 drivers (8.3%) suspected of drug associated impairment were taken to the support vehicle to be checked by the full procedure described above. In 26 cases out of 33, the oral fluid samples results were negative by both DrugWipe®5⁺ and Cozart® DDS801 devices, whereas 7 samples were positive and processed with confirmatory analysis. Three of these samples were positive for cannabinoids (Δ^9 -THC: 958 ng/mL; 37 ng/mL; 17 ng/mL); one for cocaine (40 ng/mL) and one for opiates and methadone (morphine: 229 ng/mL; codeine: 136 ng/mL; 6-MAM: 13 ng/mL; methadone: 357 ng/mL). The DrugWipe®5⁺ and Cozart® DDS801 devices yielded two false positive results for amphetamine, one for opiates (only the Cozart device), and one false negative result for opiates (only the DrugWipe device).

Conclusion: The developed protocol for roadside drug testing proved to be rapid and efficient. Oral fluid collection was feasible under roadside operation. Commercial screening devices such as Cozart® DDS801 and DrugWipe®5⁺ can be easily used by moderately trained police personnel to rapidly identify drivers who may have used drugs, although the results must be confirmed by medical examination and laboratory confirmation analysis.

Key Words: Oral Fluid, Driving Impairment, Portable Devices

Performance of Four Oral Fluid On-site Devices for Monitoring Drugged Driving Confirmed by UHPLC-MS/MS Analysis

Sabina Strano-Rossi^{*1}, Luca Anzillotti¹, Erika Castrignanò¹, Giovanni Serpelloni², Roberto Mollica², Franco Tagliaro³ and Marcello Chiarotti¹.

¹Institute of Legal Medicine, Catholic University Rome, Italy; ²Antidrug Policies Department, Rome, Italy; ³Section of Forensic Medicine, Dept. of Public Health and Community Medicine, University of Verona, Italy

Objectives: New Italian legislation on driving under the influence of drugs considers oral fluid (OF) as a possible alternative drug testing matrix. This Department of Antidrug Policies, Presidency of the Italian Council of Ministers' project evaluated applicability of four commercial on-site OF screening devices for monitoring drugged driving.

Materials and Methods: A central lab confirmed on-site kit performance by ultra-high pressure liquid chromatography tandem mass spectrometry (UHPLC-MSMS) analysis of specimen remaining after screening. Four commercially-available on-site devices were compared. Police officers tested randomly stopped drivers with two different kits side-by-side during roadside patrols. Specimen remaining after screening was confirmed by a fully validated UHPLC-MSMS method. For confirmation; deuterated internal standards were added to an aliquot of OF-buffer mixture from each on-site device collection and directly injected onto a UHPLC-MSMS operated in MRM mode monitoring amphetamine, methamphetamine, MDMA, MDEA, MDA, morphine, O-6-MAM, codeine, cocaine, methadone, benzoylecgonine, Δ^9 -THC, ketamine and cocaethylene.

Results: 950 OF specimens underwent confirmatory analysis; 21% were positive for any target analyte, 13% for cocaine and metabolites, 9% for THC, 2.5% for designers' drugs and 1.5% for ketamine. Opiates were detected in 8 cases, amphetamine in 3 subjects and methadone in 4 cases. Discrepancies between results from the two kits used to test each subject were encountered in 22% of the cases, showing differences both in sensitivity and specificity. Confirmatory analyses found: 11.6% false positives (mainly for THC and amphetamines) and 16% false negative results (mainly for cocaine and THC). Two devices performed better for THC and cocaine, with respect to the others, while two of the kits had low sensitivity and specificity for amphetamines. Ketamine is not a target analyte for any of the on-site devices we evaluated.

Conclusion: In conclusion, MS confirmation of on-site OF screening tests is necessary for forensic driving under the influence of drugs testing.

Key Words: DUID, Oral Fluid, On-Site Testing

Confirmation of Cannabinoids in Oral Fluid without Sample Pre-Treatment: UHPLC-MS/MS and SPME-GC/MS

Sabina Strano-Rossi*, Erika Castrignanò, Luca Anzillotti, and Marcello Chiarotti
Institute of Legal Medicine, Catholic University of Rome, Italy

Objective: The confirmation of tetrahydrocannabinol (THC) in oral fluid (OF) is an important issue for assessing drivers under the influence of drugs. Two methods were compared for the confirmation of THC in small amounts of OF that remained after the preliminary on-site screening with commercial devices, Concateno DDS and Mavand Rapidstat. The aim of this research was to develop a highly sensitive method with minimal sample pre-treatment that had the capability to analyze small OF volumes (100 μ L).

Method: An ultra high performance liquid chromatography tandem mass spectrometry (UHPLC-MS/MS) method and a solid-phase microextraction gas chromatographic mass spectrometry (SPME-GC/MS) method were developed separately, both applicable for small volumes of OF diluted in the preservative buffers of the screening kits. 100 μ L of the residual OF in preservative buffer was combined with 10 μ L of deuterated THC internal standard (THC-D3 1 μ g/mL) and submitted to the two analyses: A) direct injection (10 μ L) onto the UHPLC-MS/MS in positive ESI mode and B) sampling for 30 minutes with SPME (100 μ m polydimethylsiloxane fiber) and direct injection by desorption of the fiber in the GC injection port. Both methods were evaluated for LLOD, LLOQ, linearity, accuracy, repeatability, specificity, ion suppression/enhancement (for the UHPLC-MS/MS method), and carryover.

Results: The LLOD and LLOQ of THC was 2 and 10 ng/mL respectively in UHPLC-MS/MS and 1 and 2 ng/mL respectively in SPME-GC/MS. Cannabinol (CBN) and cannabidiol (CBD) were detected in SPME-GC/MS at 2 ng/mL, while their determination in LC/MS was possible only at higher concentrations (LLOD 20 ng/mL). Both methods were linear in the range from the LLOQ to 200 ng/mL (THC curve equation was $y = 0.85x + 0.008$, R^2 0.999 by SPME and $y = 0.0039x - 0.0058$, R^2 0.999 by LC/MS). By using SPME-GC/MS repeatability (%CV) and accuracy (% Error) for THC were 0.96 and 0.52 at 50 ng/mL and 3.6 and 1.1 at 2 ng/mL. By LC/MS %CV and % Error were 1.22 and 11.99 at 50 ng/mL and 6.03 and 11.27 at 10 ng/mL. No significant interferences with the analytes by endogenous components of the OF or compounds from the devices were found on 20 blank samples or on samples spiked with common drugs of abuse or medicaments. Ion suppression in LC/MS was compensated by the deuterated internal standard. The methods were applied to 40 samples from positive on-site screening tests. SPME-GC/MS confirmed the presence of THC in 19 samples with CBD and CBN detected in 11 of these THC-positive specimens. THC concentrations ranged from traces below LLOQ (2 ng/mL) to 510 ng/mL. UHPLC-MS/MS confirmed the presence of THC in 14 samples, and CBD was detected in 4 of these.

Conclusion: For the confirmation of cannabinoids in OF without sample preparation, SPME-GC/MS demonstrated better performance in terms of sensitivity, allowing the detection of CBD and CBN and a low limit of detection for THC (below 2 ng/mL). Both methods appear suitable for the confirmation of THC in small volume OF samples.

Key Words: THC, Oral Fluid, Solid Phase Micro Extraction

Evidence of Cathinone Use Through Hair Analysis Using LC-MS/MSKirsten Turner, Mathieu Martin, Emilie Vallet and **Vincent Cirimele***

Laboratoire ChemTox, Illkirch, France

Objectives: During the last few years, there has been a rapid growth in the availability of new synthetic substances (commonly known as 'legal highs') in the UK and throughout Europe (Measham et al 2010, Winstock et al 2010), the majority of which are freely available over the internet or in 'head shops'. Mephedrone and related cathinone derivatives were banned in the UK in April 2010 (The Lancet, April 2010) so it has been necessary to expand the range of cathinones included in routine testing. We have developed and validated a method for a range of cathinones in hair by LC-MS/MS to include cathinone, methcathinone, mephedrone (4-methylmethcathinone), methedrone/bk-PMMA (methoxymethcathinone), MDPV (methylenedioxypropylone), butylone/bk-MBDB (methylamino-1-(3,4-methylenedioxyphenyl) butan-1-one) and methylone/bk-MDMA (2-Methylamino-1-(3,4-methylenedioxyphenyl) propan-1-one). The major positives seen were for mephedrone and two cases where MDPV and methedrone were detected at trace levels.

Methods: After decontamination of the hair strand in methylene chloride, hair segments were cut into small pieces with scissors, weighed and incubated in methanol overnight at 40°C in the presence of deuterated MDMA (internal standard). After sonication for 15 minutes and centrifugation, the supernatant was recovered. 100µL of methanol/HCl (99:1) were added and the media was evaporated to dryness. The dry residue was reconstituted in 80µL of acetonitrile/0.1% formic acid in 2mM ammonium formate buffer (5:95) and 10 µL were injected onto the chromatographic system. The LC-MS/MS system consisted of a triple-quadrupole instrument equipped with an electrospray interface. Chromatographic separation was achieved on a C18 (2.1 x 100mm, 3.5µm) column. Tandem mass spectrometry was employed using an electrospray interface in positive ionisation mode and acquisition was done in MRM mode. The method was validated according to the parameters stated within standard operating procedures for method validation (ISO 17025) including linearity, LOD, LOQ, intra and inter-day precision, accuracy and ion suppression.

Results: Linearity was verified (0.1 to 20ng/mg). Inter and intra-day variability (%CV) were less than 20% at 0.5 and 2ng/mg. Fifty hair specimens were screened for cathinones. Eighteen were found positive for mephedrone with concentrations ranging from 0.12 to 36ng/mg with a median concentration of 0.63ng/mg. The sample reading 36ng/mg was re-analysed on a lower volume of hair sample as it was above the highest linearity point. These concentrations are in accordance with results previously produced by this laboratory for mephedrone by GCMS. MDPV and methedrone were also detected in 2 cases at trace levels (below LOQ).

Conclusion: The cathinones seem to be well incorporated in hair and the method is sensitive enough to be able to detect cathinones in subjects where occasional or regular use is suspected. The mephedrone concentrations are in the ng/mg range like other psychoactive drugs such as amphetamines. The method performs well when screening (direct solvent incubation) a large number of samples.

Key Words: Cathinone, LC-MS/MS, Hair Analysis

Concentration of Tramadol in Human HairMathieu Martin, Kirsten Turner, Emilie Vallet, Mathieu Duez and **Vincent Cirimele***

Laboratoire ChemTox, Illkirch, France

Objectives: Tramadol is a centrally-acting analgesic, used for treating moderate to moderately severe pain. In common with other opioids, tramadol is often abused by those acquiring it either by prescription or illegally. The current literature regarding the concentrations of tramadol in hair is based on the examination of a small number of specimens (1). We have documented a large number of specimens found positive for tramadol in cases where occasional or regular abuse was suspected.

Methods: After decontamination of the hair strand in methylene chloride, hair segments were cut into small pieces with scissors (<1mm), weighed and incubated in methanol overnight at 40°C. After sonication for 15 minutes and centrifugation, an aliquot of the supernatant was evaporated to dryness to proceed with the ELISA screening test. All positive results were confirmed by HPLC-MS/MS after evaporation of the remaining media and reconstitution of the dry residue with 80 µL of acetonitrile/0.1% formic acid in 2 mM ammonium formate buffer (5:95, v/v).

The HPLC-MS/MS system consisted of a triple-quadrupole instrument equipped with an electrospray interface. Chromatographic separation was achieved on a C18 (2.1 x 100 mm, 3.5 µm) column. Tandem mass spectrometry was employed using an electrospray interface in positive ionisation mode and acquisition was done in MRM mode. The HPLC-MS/MS method was validated according to the usual parameters including linearity, LOD, LOQ, intra and inter-day precision, accuracy and ion suppression.

Results: More than 200 hair specimens were screened for tramadol by ELISA followed by confirmation using HPLC-MS/MS. Ninety were found positive with concentrations ranging from 0.1 to 138 ng/mg, with a mean concentration of 11.6 ng/mg. In the literature, only one paper (1) reported tramadol concentrations in hair with values ranging from 0.176 to 16.3 ng/mg in 11 adults who were prescribed tramadol.

Conclusion: The results reported here give a reference range for tramadol concentrations in the hair of subjects who are suspected of occasional or regular use of this drug. Compared to the previously published paper (1), the tramadol concentration range is larger and is based on a larger number of samples.

References:

1. Hadidi KA, Almasad JK, Al-Nsour T and Abu-Ragheib S, Determination of tramadol in hair using solid phase extraction and GC-MS, For Sci Int, Vol 135, Issue 2 P129-136, 2003.

Key Words: Tramadol, Hair Analysis, HPLC-MS/MS

Comparison of Solid Phase Extraction Versus Direct Analysis of Hair Extracts for Cocaine-N-Oxide by LC/MS/MS

Lindsey R. Crawley*¹, Roman Aranda, IV¹, Kimberly Kaplan¹, Mark L. Miller¹, Madeline A. Montgomery² and Marc A. LeBeau²

¹Counterterrorism and Forensic Science Research Unit, Federal Bureau of Investigation, Laboratory Division, Quantico, VA, 22135, USA; ²Chemistry Unit, Federal Bureau of Investigation, Laboratory Division, Quantico, VA, 22135, USA

Objectives: Cocaine-N-oxide (CNO), a metabolite product of cocaine (COC), is likely incorporated into cocaine users' hair. The detection of CNO in hair may help distinguish cocaine findings in hair due to environmental exposure versus ingestion. A sensitive method for CNO in hair is under development to assist in differentiating cocaine ingestion from environmental exposure. Analysis of CNO in spiked hair extracts using LC/MS/MS was evaluated with and without the incorporation of a solid phase extraction (SPE) procedure.

Materials and Methods: Hair samples were washed with dichloromethane and then ground using 2.4 mm glass beads in a FastPrep FP120 ball mill. Experiments were performed with control hair samples (~10 mg) that were spiked with 120 pg of CNO and COC standards and 360 pg of deuterated cocaethylene (CED3) internal standard. Samples were extracted with 2:1 water:methanol in 0.1% formic acid (v/v) overnight at room temperature and then filtered through a 3,000 molecular weight cut-off (MWCO) filter to remove particulates, proteins, and to minimize matrix interference from ground hair. A Spark Holland Symbiosis HPLC system was used for the automated LC/MS/MS method. Direct analysis, C8 and C18 SPE cartridges were evaluated for CNO detection with a Waters' Xterra 5µm MS C18 column (3x50mm) coupled to an Applied Biosystems QTRAP 5500 mass spectrometer (selected reaction monitoring mode).

Results: A variety of human hair samples (negative controls spiked with standards) were analyzed for the comparison. Prior screening of several Symbiosis SPE cartridge types narrowed the focus to C8 and C18 cartridges. The direct LC/MS/MS analyses of different negative hair controls have shown more intense chromatographic peak heights and larger peak areas for CNO, COC, and CED3 in spiked hair samples than when C8 or C18 solid phase extraction was incorporated into the analysis scheme. No interferences were noted with or without SPE but more intense additional and more intense peaks were observed in direct LC/MS/MS.

Conclusions: The direct LC/MS/MS analysis of cocaine-N-oxide in hair extracts provides superior peak areas and heights when compared to SPE LC/MS/MS. Matrix effects appear to interfere with SPE recoveries due to cartridge overload.

Key Words: Cocaine-N-Oxide, Hair, LC/MS/MS

Benzodiazepines in Oral Fluid: Effect of Screening Cut-Off Concentration

Margaux Garnier, **Cynthia Coulter***, James Tuyay, Jonathan Orbita, Jr., and Christine Moore
Immunoanalysis Corporation, Pomona, CA, USA

Objectives: The concentration of benzodiazepines in oral fluid is considerably lower than the concentration in corresponding blood specimens. In an effort to eliminate false negative results in oral fluid screening, a cut-off concentration of 10 ng/mL for benzodiazepines was validated in our facility. The objective of our work was to determine how many additional oral fluid specimens will test positive for benzodiazepines by using a cut-off level of 5 ng/mL and how many positive specimens will be missed (test negative) by using a 20 ng/mL cut-off level.

Methods: Oral fluid specimens received into our laboratory during routine testing for drugs of abuse were analyzed with an ELISA screen for benzodiazepines (using oxazepam as the calibration standard). For confirmation using LC-MS/MS, a limit of quantitation of 0.5 ng/mL was used. The absorbance values for ELISA calibration curves established at 5, 10 and 20 ng/mL were initially used to determine positivity of oral fluid samples (with 10 ng/mL as the decision point) and were re-evaluated by assessing the number of additional positives with a 5 ng/mL cut-off and the number of missed positives with a 20 ng/mL cut-off.

Results: Data were extracted from oral fluid batches received over the last year. A total of 125 specimens screened above 5 ng/mL. Of the 125 specimens, 62.4% (n=78) were above 20 ng/mL, 22.4% (n=28) were between 10 and 20 ng/mL, and 15.2% (n=19) between 5 and 10 ng/mL. Of those 19 specimens positive between 5 and 10 ng/mL, 8 were present in sufficient amounts for confirmation; all 8 were positive for benzodiazepines (4 contained alprazolam; one lorazepam; one diazepam only and two nordiazepam and diazepam).

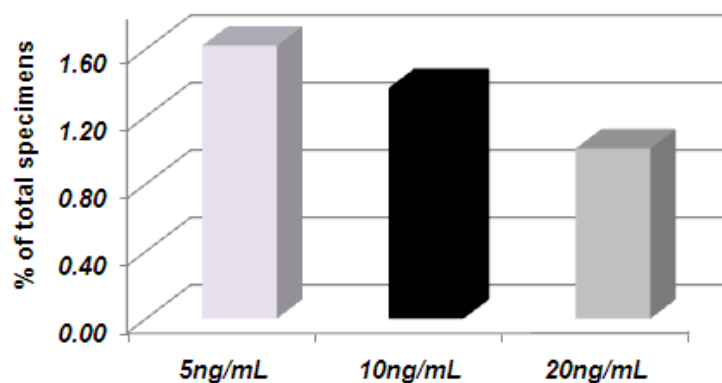

Conclusions: A screening cut-off concentration of 5 ng/mL of oxazepam for benzodiazepines in oral fluid is recommended. For each doubling of the test cut-off level, 15 – 20% of positive specimens would not be subjected to confirmation analysis.

Key Words: Benzodiazepines; Oral Fluid; Cut-Off Concentration

Hair Analysis for Estimation of Exposure to Methamphetamine and its Related Compounds

Kenichiro Nakashima*¹, Yuki Sugimoto¹, Rie Ikeda¹, Mitsuhiro Wada¹, Kazutomo Isono² and Naotaka Kuroda¹

¹Graduate School of Biomedical Sciences, Nagasaki University, Nagasaki, Japan; ²Department of Pediatrics, Hyogo College of Medicine, Hyogo, Japan

Objectives: Abuse of methamphetamine (METH) and related compounds such as amphetamine (AMP), 3,4-methylenedioxyamphetamine (MDMA) and 3,4-methylenedioxyamphetamine (MDA) has been a severe social problem worldwide. Hair analysis, which can provide information on the long term exposure to drugs, has been successfully employed as a complementary analysis to urine or blood. In this study, hair analysis of METH and related compounds was performed on subjects whose urine tested negative at their registration, and its clinical availability was discussed. Furthermore, a case in which amphetamines (AMPs) were determined in a neonate's hair and meconium to estimate the exposure of METH during pregnancy is also reported.

Methods: One mg (0.5 mg for neonate's hair) of hair spiked with 1-methyl-3-phenylpropylamine (as an internal standard) was used for determination of AMPs. The hair sample (total length=*ca* 3 cm) was divided into 2 segments; root and tip. After digestion with 1 M NaOH, the samples were extracted with heptane and the organic layer was evaporated and derivatized with 4-(*N,N*-dimethylaminosulfonyl)-7-fluoro-2,1,3-benzoxadiazole. Ten mg of meconium was used to determine of AMPs by a standard addition method. Determination of AMPs in hair was performed by the semi-micro HPLC-peroxyoxalate chemiluminescence method according to our previous method [1].

Results: Sixteen subjects' hair samples were evaluated. AMPs in patients' hair were determined in the range of 0.12-6.73 ng/mg (METH, n=11), 0.86-2.47 ng/mg (AMP, n=5), 0.1-0.59 ng/mg (MDMA, n=5) and 0.52-0.83 ng/mg (MDA, n=2). Hair analysis at registration was available to obtain information about drugs abused by patients. In the neonatal case, the concentrations of METH in the segments were 1.68 ± 0.18 ng/mg (root) and 1.29 ± 0.03 ng/mg (tip). AMP was not found in any fragments. The concentrations of METH and AMP in meconium with triplicate measurements were 0.27 ± 0.04 ng/mg and 0.16 ± 0.03 ng/mg, respectively. Exposure of the neonate to AMPs during the pregnancy was confirmed.

Conclusions: Determination of AMPs in patients' and neonate's hair samples may be important in identifying exposure to AMPs.

References:

1. S. Nakamura *et al.*, *Anal. Bional. Chem.*, 387, 1983-1990 (2007).

Key Words: Methamphetamine, Hair, Meconium

UPLC-MS/MS Analysis of Drugs and Metabolites in Hair

Carolien Boone *, José Roque, Albert Dijkhuizen, Roelof Oosting and Beitske Smink
Netherlands Forensic Institute, The Hague, The Netherlands

Objectives: An ultra-performance liquid chromatography–tandem mass spectrometry (UPLC-MS/MS) method is presented for the screening of 58 drugs of abuse and metabolites in hair. Targeted drugs include methadone, cannabinoids, opioids, amphetamines, benzodiazepines, cocaine and related compounds. We present validation results of the method and 25 cases of drugs in hair performed by the Netherlands Forensic Institute from January 2007 to August 2009.

Materials and Methods: Specimen preparation consisted of segmentation (1 cm, >10 mg), washing (3 times with 5 mL dichloromethane), grinding (30 min) and methanol extraction (overnight, 37°C). Analysis was performed on a Waters Acquity UPLC-system with a Waters Quatro premier XE triple quadrupole mass spectrometer. Chromatography employed a reversed-phase UPLC column (BEH C-18, 100 x 2.1-mm i.d., 1.7 µm particle diameter) using an injection volume of 10 µL, a flow rate of 500 µL/min and gradient elution (methanol/10 mM ammonium bicarbonate pH 10.0, 5/95 to 100/0) with a total run time of 25 min. ESI was performed in the positive ion mode, with optimized CID voltages for each compound (9 to 50 eV). For each target-compound, two MRM were monitored and for each deuterated internal standard, one MRM was monitored.

Limits of detection and quantification were in the order of 0.01 ng/mg hair and were always 10 times lower than cut-off levels from the literature. Imprecision and accuracy were <20% for most of the 58 compounds. Furthermore, results of an external quality control sample with 11 drugs in hair (Medichem, Germany) were within the accepted range.

Results: Results of 25 forensic cases will be presented. Most hair specimens were drug positive (76%, 19/25). In 32% (8/25), there was an indication for repetitive active exposure (high concentrations of drugs found in more than one segment), mostly to multiple drugs (75% 6/8). It was noticeable that in 28% (7/25) of the cases benzodiazepines were found, sometimes in high concentrations (e.g. demoxepam 4.5-7.8 ng/mg and desmethyldiazepam (0.01-6.9 ng/mg). THCCOOH was found in 12% (3/25) of the cases (0.2- 7.3 ng/mg).

Conclusions: Our sensitive, selective and rapid UPLC-MS/MS hair analytical method allows us to identify many frequently abused drugs in The Netherlands. Identification of multiple drugs in many of our specimens highlights the importance of incorporating multiple drugs into hair analytical methods for which small specimen amounts are available.

Key Words: Hair, UPLC-MS/MS, Drugs Screening

Screening of Illicit Drugs in Hair with a Combination of Enzyme Linked Immunosorbent Assay (ELISA) and Enzyme Multiplied Immunoassay Technique (EMIT)

Paul Powles*¹, Sian Bevan¹, John O'Sullivan¹ and Allan Traynor²

¹Concateno Cardiff, Cardiff, UK; ²Concateno South, Canary Wharf, London, UK

Objectives: To compare and contrast enzyme linked immunosorbent assay (ELISA) and enzyme multiplied immunoassay technique (EMIT) procedures for screening illicit drugs from hair extracts, exploring their advantages and disadvantages. Considerations include time, cost and specificity of each technique using conventional extraction procedures. A recent commercial hair extraction reagent (VMA-T, Comedical/Microgenics) was examined as a potential alternative for EMIT analyses.

Methods: Hair archive samples, ex-proficiency test and commercial samples were analysed. Samples for ELISA/EMIT comparison were extracted by ultrasonication, followed by sodium hydroxide hydrolysis and extraction using chloroform:propan-2-ol, 9:1 (v/v). The combined extracts were reconstituted in buffer (pH 7.2) for analysis by either ELISA using a Triturus analyser or EMIT using an ILAB 650 analyser. The ELISA used kits for forensic matrices (Immunalysis or Cozart) whereas EMIT used DRI assay kits for urine (Microgenics). Both kits were used to assay the same groups of analytes: cocaine, cannabinoids, opiates, amphetamines, methadone and metamphetamines (EMIT assay was specific for 3,4-methylenedioxymetamphetamine [MDMA]). In-house standard solutions were prepared to provide concentrations 2-40 ng/mL for both procedures. The applied cut off concentrations were 5 ng/mL for all analytes except cannabis, which was 2 ng/mL. VMA-T reagent utilised direct addition of the reagent to a hair sample followed by a 1 h digest at 100°C. Following cooling and centrifugation, the extract was analysed directly using EMIT.

Results: The two techniques (ELISA and EMIT), using conventional extraction gave equivalent results for most samples and analytes. EMIT gave an unacceptable proportion of false positives for 3,4-methylenedioxymetamphetamine (40%); ELISA gave a high proportion of false positives for cannabis (18%) and opiates (7%); other analytes had <3% false positives for ELISA. VMA-T reagent using EMIT gave superior screening results with no false positives; however, published data indicates that the digestion process converts mono-acetyl morphine to morphine (100%) and cocaine to benzoylegonine (65-70%), which would preclude confirmation analysis on the same sample extract for these analytes.

Conclusion: EMIT, combined with ELISA for MDMA, provided the most effective method for illicit drugs screening of hair extracts. VMA-T reagent was effective for screening but may be restrictive for confirmation analysis using the same specimen.

Key Words: ELISA, EMIT, VMA-T Reagent

Detection of Phosphatidylethanol Species in Dried Blood Spots by LC-MS/MS

Andrea Faller*¹, Barbara Richter², Matthias Kluge², Patrick Koenig⁴, Helmut K. Seitz⁴, Annette Thierauf⁶, Heike Gnann⁶, Michaela Winkler⁷ and Gisela Skopp¹

¹Institute of Legal and Traffic Medicine, Heidelberg, Germany; ²Psychiatric Center Nordbaden, Wiesloch, Germany; ⁴Salem Medical Center, Heidelberg, Germany; ⁶Institute of Legal Medicine, Freiburg, Germany; ⁷Institute of Legal Medicine, Ulm, Germany

Objectives: Biomarkers of ethanol misuse may aid detection, treatment efforts and control of abstinence in subjects with alcohol related conditions. Phosphatidylethanol (PEth), formed extrahepatically in a reaction between phosphatidylcholine and ethanol, has a detection window in blood of about 1 to 3 weeks after a period of heavy drinking. PEth is currently under investigation as a promising biomarker to indicate recent alcohol consumption. The use of dried blood spots (DBS) for quantitative analyses has been documented since 1913; their use has recently increased for neonatal metabolic screening. The main advantage of analyzing DBS is easy handling, a decreased risk of infection and increased stability of labile analytes. Therefore, we developed a method for the quantitative measurement of PEth in DBS and compared these results with PEth concentrations obtained from the matching whole blood.

Methods: DBS (100µl blood spotted on Whatman #903 paper and dried at ambient temperature) and 100µl of matching whole blood specimens from 40 inpatients in alcohol withdrawal (previous consumption: 22.5-300 g ethanol/day) were analyzed by liquid-liquid extraction (0.5 M sodium acetate buffer/isopropanol/n-hexane 1:1.5:1.75 by vol.) using 1,2-di-(9Z-octadecenoyl)-sn-glycero-3-phosphopropanol (PProp 18:1/18:1) as internal standard. Dried samples were redissolved in mobile phase (50 µL) and injected into a HPLC system (Agilent 1100 series) equipped with a HyPurity C4 column (50 • 3 mm, 5 µm; Thermo Scientific), coupled to an API 4000 tandem mass spectrometer (AB Sciex) for determination of 1,2-di-(9Z-octadecenoyl)-sn-glycero-3-phosphoethanol (PEth 18:1/18:1, *m/z* 727.5→281.2, 727.5→463.3), 1-palmitoyl-2-oleoyl-sn-glycero-3-phosphoethanol (PEth 16:0/18:1, *m/z* 701.5→281.2, 701.5→255.3) and PProp 18:1/18:1 (*m/z* 741.4→281.2) in the negative ionization mode. Mobile phases were: 2 mM ammonium acetate buffer pH 7.9 (A) and isopropanol (B) (30→60% A within 8 min, re-equilibration for 2 min, flow rate: 200 µL/min). The bias and 95% limits of agreement (LOA) between concentrations of PEth for the two types of specimens were determined by the Bland and Altman method.

Results: PEth concentrations in whole blood from subjects ranged from 46.1 – 3,360 ng/mL (PEth 18:1/18:1; mean 461.7 ng/ml) and 922 – 213,000 ng/mL (PEth 16:0/18:1; mean 23,375 ng/mL), PEth values in DBS samples ranged from 35.8 – 3,360 ng/mL (PEth 18:1/18:1; mean 457.6 ng/mL) and 900 – 213,000 ng/mL (PEth 16:0/18:1; mean 23,470 ng/mL). Mean concentration ratios (blood/DBS) were 1.2 for PEth 18:1/18:1 and 1.0 for PEth 16:0/18:1. The mean bias for PEth 18:1/18:1 was estimated at -4.3 ng/mL with LOA ranging from -30 to 21.5 ng/mL. For PEth 16:0/18:1, the mean bias was -4.3 ng/mL and LOA were -1,270 and 1,461 ng/mL.

Conclusion: The Bland-Altman difference plots showed a single outlier for PEth 18:1/18:1, whereas all differences for PEth 16:0/18:1 were within the LOA. PEth concentrations from DBS were comparable to those in whole blood; DBS for PEth will facilitate storage and shipping of this delicate analyte.

Key Words: Dried Blood Spots, Phosphatidylethanol, LC-MS/MS

A Study of Blood Alcohol Stability in Forensic Antemortem Blood Samples

Xiaoqin Shan*, Nicholas B. Tiscione, Ilene Alford, and Dustin Tate Yeatman
Palm Beach County Sheriff's Office, 3228 Gun Club Road, West Palm Beach, FL 33406, USA

Objectives: Forensic toxicologists are occasionally challenged in court about the difference in blood alcohol concentration (BAC) results for the same case generated from analyses conducted months or years apart, as well as the possibility of microorganism-generated alcohol in antemortem blood samples. To address these issues, long-term storage effects on alcohol stability in preserved authentic forensic antemortem blood samples were investigated.

Materials and Methods: Thirty-two whole blood case samples (each with two tubes of blood) were used for this study. One tube from each case was analyzed for BAC for court proceedings of driving under the influence (DUI), and all blood samples then were stored refrigerated. After storage (ranging from 13 to 39 months), both tubes of blood for each case were reanalyzed for BAC and the results were compared to the original analysis.

Results: Seven samples originally negative for alcohol analysis remained negative. The comparative data for twenty-five originally-positive samples demonstrated various BAC losses in both tubes. A significant loss (mean 0.015 g/dL, standard deviation (SD) ± 0.011) was observed in previously opened tubes compared to unopened tubes (mean \pm SD 0.010 \pm 0.003 g/dL). The difference in BAC losses between previously opened and unopened tubes was significant by a paired Student *t*-test at the confidence level of 95%. In order to determine the effect of other storage conditions, blood samples then were stored at room temperature (RT) for 6 months and at 38°C for 7 and 28 days and analyzed for BAC at the end of each storage period. The seven alcohol negative cases remained negative when stored at RT or 38°C. Six months of storage at RT decreased BAC further for both tubes of the alcohol-positive cases with a mean (\pm SD) loss of 0.014 g/dL (\pm 0.005). Once again, previously opened tubes showed greater loss in alcohol (mean \pm SD 0.015 \pm 0.004 g/dL) than previously unopened tubes (mean \pm SD 0.012 \pm 0.004 g/dL). This difference was determined to be significant by a paired Student *t*-test at the confidence level of 95%. Storage at 38°C for 7 days did not cause any significant change in BAC. Storage at 38°C for 28 days caused some loss in BAC (mean \pm SD 0.006 \pm 0.003 g/dL). Although the BAC levels before and after storage at 38°C for 28 days were determined to be significantly different by a paired Student *t*-test at the confidence level of 99.5%, the differences, for the majority of cases, were within the accuracy of the analytical method.

Conclusions: Our study with authentic DUI blood samples showed that 1) there was no microorganism-generated alcohol in forensic preserved antemortem blood samples; 2) long term storage either under refrigeration, at or above room temperature decreased BAC, indicating that reanalysis of blood alcohol after long term storage would result in lower BAC results than the true values at the time of blood collection.

Key Words: Blood Alcohol Stability, Antemortem, Blood Storage

Chronic Excessive Alcohol Consumption Diagnosis: Comparison Between Traditional Biomarkers and Ethyl Glucuronide in Hair in an Authentic Population

L. Morini*¹, C. Varango², C. Filippi², C. Rusca³, P. Danesino¹, F. Cheli⁴, M. Fusini⁴, G. Iannello⁵ and A. Groppi¹.

¹Department of Legal Medicine, Forensic and Pharmacotoxicological Science, University of Pavia, Italy; ²Addiction Department of Lodi's Local Health Centre, Italy; ³Prevention Department of Lodi's Local Health Centre, Italy; ⁴Addiction Department of Bergamo's Local Health Centre; ⁵Social Direction of Lodi's Local Health Centre, Italy.

Objectives: This study compared ethyl glucuronide (EtG) in hair as a marker of chronic ethanol abuse with five traditional serum markers of abuse.

Materials and Methods: Seventy-six subjects tested for chronic alcohol abuse for different purposes were recruited. EtG was detected in hair, while the analyses of carbohydrate deficient transferrin (CDT), alanine transaminase (ALT), aspartate transaminase (AST), gamma-glutamyl transferase (γ GT), mean corpuscular volume (MCV), mean corpuscular hemoglobin (MCH) were performed in sera.

Results: Twenty-six of 76 cases examined were judged by the medical doctors as subjects with alcohol abuse problems, therefore not eligible for driver's license renewal, liver transplant etc. EtG in hair (SE=0.68, SP=1.00) showed the best sensitivity and specificity compared to the other biomarkers investigated. Among the traditional biomarkers, only CDT proved suitable for forensic purposes due to the high specificity (SP=1.00) although sensitivity (0.27) was poor. The percentage of positive samples decreased for all biomarkers by excluding subjects with hepatic diseases, except for EtG and CDT, suggesting that these two biomarkers could be less affected by false positive results, due to hepatic pathologies. If CDT and EtG data were combined, sensitivity increased (one sample tested negative for EtG and positive for CDT).

Conclusions: This study showed that when EtG in hair and CDT results are combined, sensitivity in chronic alcohol abuse diagnose clearly improved, suggesting that complementary analysis of both these biomarkers provides the best diagnostic tool in suspected cases of chronic excessive alcohol consumption.

Key Words: Ethanol Biomarkers, Ethyl Glucuronide, Chronic Alcohol Abuse

Ethyl Glucuronide by LC-MS/MS: Where Are the Limits?

Wolfgang Weinmann*, Ana Hernández Redondo, Lars Ambach, Stefan Schürch, Claudia Bühr and Stefan König
Institute of Forensic Medicine, Bern, Switzerland

Objectives: Ethyl glucuronide (EtG) is a metabolite formed by the glucuronidation of ethanol in the body. The analysis of EtG is used as a biomarker to test for ethanol ingestion. Currently LC-ESI-MS/MS is widely used for determination of ethyl EtG in urine, blood and hair samples as well. Due to its high sensitivity compared to other existing instrumentation, any pre-concentration steps or further purification steps by off-line SPE can often be avoided. Furthermore, post column addition (PCA) of organic solvents, such as isopropanol or acetonitrile, results in increased signal intensities and therefore higher signal to noise ratios.

Materials and Methods: For our newly developed method 30 mg aliquots of hair samples were cut into small pieces followed by a liquid extraction using 0.5 mL of water in an ultrasonicator bath for two hours. After centrifugation, the supernatant solution was filtered in order to eliminate any residual hair pieces and 0.5 mL of acetonitrile was added to the aqueous solution. Then the solution was evaporated to dryness under a gentle stream of nitrogen. Reconstitution (with a volume of 50 μ L) was performed with a solution of water and acetonitrile (95/5; v/v). No additional SPE or further clean-up step was necessary. Chromatographic separation was carried out on a Dionex HPLC system with a Phenomenex column (Synergi Polar-RP, 250 x 2.0 mm, 4 μ m). Mobile phase A consisted of water and 0.1% HCOOH, mobile phase B of acetonitrile and 0.1% HCOOH. As quantifier ion the transition m/z 221>75 was used, and both ion transitions m/z 221>85 and 221>57 were used as qualifier ions and had to meet the criteria for predefined ratios between quantifier ion and qualifier ions. For the internal standard (EtG-D5) the ion transitions 226>75 and 226>85 were applied. The method was fully validated using blank hair (from abstinent persons and children) according to the guidelines.

Results and Conclusions: The required limits (detection limit < 2.0 pg/mg and a cut-off of 7.0 pg/mg for abstinence control) were achieved without further sample clean-up or SPE. With a highly sensitive LC-MS/MS triple quadrupole instrument and appropriate chromatographic improvements, existing sample preparation could be simplified and overall analysis time (including sample preparation) significantly shortened. This current method allows preparing up to two hundred samples in a single working day in order to have our instrument run continuously over several days. Therefore previous limitations due to the tedious and time consuming sample preparation procedure could be overcome and the analysis of EtG in hair has become a routine analysis equivalent to analysis of whole blood or urine samples. During the last six months hundreds of case samples originating from the traffic security department, where previously convicted drivers had to prove their alcohol abstinence or demonstrate appropriate (“social”) drinking behavior, were analyzed with our method. Approximately 70% of these subjects showed an EtG concentration below 7.0 pg/mg EtG, whereas 15% were between 7.0 pg/mg and 30 pg/mg. The remaining 15% showed EtG concentration above the 30 pg/mg limit.

Key Words: Hair Analysis, Ethyl Glucuronide, LC-MS/MS

GC-MS/MS Method for the Measurement of Ethyl Glucuronide in Human Urine and Serum

Alaa AlSaabi*^{1,2}, Gilles Tournel^{1,3}, Benjamin Hennart^{1,2}, Jérémy Thomas², Delphine Notebaert² and Delphine Allorge^{1,2}
¹EA4483, Faculté de Médecine, Univ. Lille-Nord de France, France; ²Laboratoire de Toxicologie, Centre de Biologie-Pathologie, CHRU Lille, France; ³Institut de Médecine Légale, CHRU Lille, France

Objectives: Ethyl-β-D-6-glucuronide (EtG) is a minor phase-II metabolite of ethanol. It has been proposed as a biomarker of ethanol intake in a variety of clinical and forensic contexts. This work aimed to develop and validate a gas chromatography negative chemical ionization tandem mass spectrometry (GC-NCI-MS/MS) method to measure EtG in urine and serum with both high sensitivity and specificity.

Materials and Methods: Urine samples (1 mL) and serum samples (0.5 mL) were diluted 40-fold with distilled water and 50 μL of EtG-D5 (1 μg/mL in MeOH) was added as an internal standard. EtG was extracted from samples by solid-phase extraction (SPE) using Mixed Mode Anion-Exchange (Oasis MAX) extraction cartridges (Waters, Saint-Quentin en Yvelines, France). After derivatization with pentafluoropropionic anhydride (PFPA), the analysis was performed using an AT₅-ms (30 m × 0.25 mm, 0.25 μm) (Alltech, Templemars, France) fused silica capillary column. Samples underwent NCI using methane as the reagent gas. The mass spectrometer was operated in the multiple reaction monitoring (MRM) mode using the transitions m/z 496→163 for EtG quantitation, m/z 347→163 and m/z 496→119 for EtG identification and m/z 501→163 for EtG-D5. The validation procedure was performed according to the French Society of Analytical Toxicology (SFTA) and the French Committee of Accreditation (COFRAC; LAB GTA 04) guidelines. The validation parameters were based on the following criteria: specificity, linearity, intra- and inter-day precision (repeatability and intermediate precision), limit of detection (LOD), and limit of quantitation (LOQ).

Results: The calibration curves were linear in the concentration range 10 to 10000 ng/mL and 5 to 1000 ng/mL in urine and serum, respectively, with a coefficient of determination (r^2) above 0.994. The LOD and LOQ values were 5 and 10 ng/mL, respectively, for both matrixes. The intra- and inter-day precision (relative standard deviation RSD%) and relative bias were less than 20%.

Table: RSD% values of the intra- and inter-day precision for urine and serum matrixes.

Matrices	Urine						Serum					
Concentration	C1	C2	C3	C4	C5	C6	C1	C2	C3	C4	C5	C6
RSD% ^a	6.66	2.56	8.16	6.18	9.87	6.1	7.69	8.59	12.14	9.57	6.48	5.34
Matrices	Urine						Serum					
Concentration	C2=100 ng/mL			C4=5000 ng/mL			C2=10 ng/mL			C4=100 ng/mL		
RSD% ^b	5.5			9.62			8.64			4.49		

^a RSD% values of the intra-day precision

^b RSD% values of the inter-day precision.

In addition, no influence of interfering compounds on the signal was observed for both EtG and EtG-D5.

Conclusion: To our knowledge, this is the first report of the application of a GC-MS/MS method for EtG measurement in urine and serum. The method has been validated successfully according to SFTA and COFRAC guidelines and is suitable for the measurement of low concentrations of EtG in both urine and serum. Furthermore, the LOQ appears to be better than those reported in the literature using other validated analytical techniques. This method could be used routinely for EtG measurement in various clinical and forensic contexts.

Key Words: Ethanol, Ethyl Glucuronide, GC-MS/MS

Carbohydrate Deficient Transferrin: An Indication of Risk for Car Accidents with Injuries

Federica Bortolotti^{1*}, Daniela Sorio¹, Giovanna Carli¹, Allison Rubino¹, Timothy M. Palmbach² and Franco Tagliaro¹

¹Department of Public Health and Community Medicine, Section of Forensic Medicine, University of Verona, Italy;

²Forensic Science Department, University of New Haven, West Haven, CT, USA

Objectives: Carbohydrate Deficient Transferrin (CDT) refers to a group of minor glycoforms of transferrin whose serum concentration increases after chronic sustained alcohol intake. Because of its high diagnostic specificity, CDT is currently one of the most common markers of chronic alcohol abuse. A physical fitness assessment using CDT concentrations is performed for subjects attempting to obtain a new driving license after earlier confiscation related to alcohol problems. However, there are only a few published studies supporting the correlation between CDT values and the risk of driving under the influence of alcohol. To the best of our knowledge, no studies assessed the prevalence of chronic alcohol abusers among drivers involved in car accidents. The aim of this study was to evaluate the effectiveness of elevated CDT concentrations among chronic alcohol-drinking drivers as predictive of higher risk of traffic accidents with injuries.

Materials and Methods: Blood samples from 393 car drivers hospitalized for injuries related to car accidents (group A) were collected at admission to the hospital. The control group consisted of blood samples from 236 subjects in safety-sensitive job positions undergoing mandatory toxicological analyses. The CDT analysis was performed on all serum samples with a High Performance Liquid Chromatography (HPLC) method fully described by Bortolotti et al¹. The positive cut-off was 1.90%. Group A blood samples also were tested for alcohol by Head Space-Gas Chromatography (HS-GC). Analytical sensitivity for this method was 0.01 g/L; the blood alcohol concentrations (BAC's) of legal relevance in Italy are 0.5 g/L and 1.5 g/L.

Results: Qualitative analysis of CDT concentrations (1.90% cut-off) showed an increased percentage of "CDT positives" in group A as compared to the control group (10.18% versus 0.42%). When excluding all subjects with BAC below the legal limit of 0.5 g/L, the percentage of CDT positives increased to 42%. Quantitative analysis of CDT levels showed a statistically significant increase in the average CDT concentrations in group A versus group B (mean \pm standard deviation: 1.37% \pm 1.51 in group A, 1.00% \pm 0.26 SD in group B).

Conclusions: These data support the hypothesis that CDT analysis allows for prediction of injury risk in severe traffic accidents.

References:

1. Bortolotti F et al., *Clin Chem* 51 (2005) 2368-71.

Key Words: Carbohydrate Deficient Transferrin, Blood Alcohol Concentration, Car Accidents

Detection of Ethanol Consumption Biomarkers (Ethyl Glucuronide and Ethyl Sulfate) in Saliva by LC/MS/MS

Erica A. Guice*, Heather Workman, and Matthew Montgomery
Western Slope Laboratory Troy, MI, USA

Introduction and Objectives: Advanced toxicology testing, comprehensive, flexible therapeutic drug monitoring at trace levels without screening, has been growing exponentially over the last decade. Three major segments of advanced toxicology testing are pain management, behavior management, and addiction cessation monitoring. In each, the need to ensure compliance with the treatment regimen is essential. Alcohol cessation is imperative for compliance in these segments due to drug-drug interactions and mediation of drug effects by alcohol. Most physicians rely upon blood or urine testing to demonstrate compliance in the aforementioned segments. Although both are appropriate matrices for drug testing, there are difficulties that limit the efficacy of these programs. Oral fluid testing has increased in popularity due to its ease of collection, relationship to plasma levels, and lack of adulteration potential. Here, we discuss the development of an advanced toxicology oral fluid method by high pressure liquid chromatography tandem mass spectrometry (LC/MS/MS) for ethyl glucuronide (EtG) and ethyl sulfate (EtS), alcohol consumption biomarkers.

Materials and Methods: Saliva samples were collected using a modified Salivette® (Sarstedt) device. A 300 µL aliquot of saliva was mixed with three volumes of filtered (0.45 µm, Restek) acetonitrile containing internal standards of deuterated EtG and EtS. The sample was centrifuged at 220 x g for 10 min and was filtered into a sample vial. All standards were purchased from Cerilliant. Samples were run on a MicroMass™Ultima mass spectrometer coupled to an Alliance 2795 HPLC. Mobile phase contained 0.2% formic acid in water/acetonitrile mixture. All samples were run on a Hypercarb 5µm, 100 x 2.1 mm column (Thermo Scientific). The method was validated for precision, accuracy, linearity, lower limits of detection and quantification in both matrix and solvent, where applicable.

Results: We were able to achieve adequate resolution and separate the analytes from the matrix. In addition, all compounds were linear from 50- 5000 ng/mL with a coefficient of determination (r^2) of at least 0.999 for all compounds. Imprecision has a specification limit of $\pm 20\%$, however repeated injections were under $\pm 10\%$ for all 6 transitions. Similarly, inaccuracy has a specification limit of $\pm 20\%$ and repeated injections were under $\pm 10\%$ at low levels (< 100 ng/mL). The accuracy was tighter at higher concentrations. Finally, the lower limit of detection and quantification was tested as low as 25 ng/mL for both EtG and EtS.

Conclusion: In summary, we were able to develop an advanced toxicology method that tests for ethanol consumption in oral fluid in less than 5 minutes using LC/MS/MS. This method is robust, sensitive and specific.

Key Words: Ethanol, Saliva, LC/MS/MS

Carbohydrate-Deficient Transferrin (CDT) as an Alcohol Biomarker: Influence of Age, Gender, Liver Disorders and Antiepileptic Medication

Peter Loucka^{*1}, Jakub Minar¹, Ales Horna², and Michal Pohludka³

¹Spadia Lab, a.s. Clinical Laboratories, Ostrava, Czech Republic; ²Radanal s.r.o., Pardubice, Czech Republic; ³Bio-Rad s.r.o., Prague, Czech Republic

Objectives: Among several laboratory tests routinely used in clinical and forensic medicine, carbohydrate-deficient transferrin (CDT) is considered the most specific biochemical marker for detection of chronic alcohol abuse and is used for abstinence monitoring during treatment. Disialotransferrin (DST) is the primary target molecule for CDT measurement (expressed as a relative amount, %CDT). This study evaluates some of the differences in %CDT in relation to age, gender, liver disorders and antiepileptic medication.

Materials And Methods: %CDT was determined in 457 serum samples (307 men, 150 women) routinely investigated for suspicion of alcohol abuse. Disialotransferrin was quantitated on a VariantTM HPLC (Bio-Rad, Germany) using the commercially available kit, “%CDT by HPLC” (Bio-Rad). Values higher than 1.9% were classified as positive. This cut-off value is given with the Instructions for Use, Bio-Rad.

Results: 46% of male specimens and 26% of female specimens were determined to be CDT positive. In the CDT positive group ($p < 0.001$), as well as in CDT negative group ($p < 0.05$), males displayed significantly higher CDT values than females. Age was not correlated with %CDT. When patients were divided in age classes within sex subgroups, no significant differences in CDT values was observed. 29% of subjects were diagnosed with liver disorder with non-alcoholic related causes; 34% of these subjects were CDT positive. A statistically significant differences in %CDT values were observed between groups with and without liver disorder ($p < 0.05$). Gamma-glutamyl transferase (g-GT) was not correlated with CDT. However, in 68% of CDT negative subjects elevation in g-GT levels was seen. In the group of 51 patients treated for epilepsy, 41% were determined to be CDT positive.

Conclusion: Gender differences in CDT values indicate the potential for using different cut-off values for men and women. Diagnosis of chronic alcohol abuse should always be made based on a clinical background, CDT, and g-GT levels, and not on a single CDT value alone.

Key Words: Carbohydrate-Deficient Transferrin (CDT), Alcohol Biomarker, Disialotransferrin

Assessment of Alcohol Intoxication via Visual Observations and Blood Alcohol Concentrations by the Widmark and Microdiffusion Methods

Dóris Sandra Uría Huaita^{1,*}, Carmen Cuiza Campana², Adolfo Arturo Mercado Millán Master³ and José Daniel Bogado Laserna⁴

¹ Institute of Forensic Science and Criminal Investigation –UNIVALLE Cochabamba, Bolivia; ²Forensic Research Institute - Fiscalía General Sucre Bolivia; ³Institute of Forensic Research - Fiscalía General Sucre Bolivia; ⁴ University of Valle, Bolivia

Introduction: The Code and Traffic Regulations were established to restrict activities leading to intoxication and subsequent endangerment of men, women and children. The city of Cochabamba, Bolivia cannot effectively enforce the Alcohol Testing Policy because there are no protocols for chain of custody for biological specimens collected from individuals suspected of violating the policy and no quality assurance for alcohol testing. This in turn precludes a fair criminal justice system. In such situations, laboratories responsible for determining blood alcohol concentrations are obliged to ensure testing quality and supportable chain of custody for samples to ensure reliable and accurate results.

Objectives: To compare impairment due to alcohol intoxication with corresponding blood alcohol concentrations analyzed by the Widmark method at the Institute of Forensic Science and Criminal Investigation (ICFIC - Cochabamba) and by the Conway microdiffusion method at the Institute of Forensic Research (IDIF - Sucre).

Materials and Methods: The study population consisted of 22 men and women from different professions (biochemists, physicians, dentists, psychologists, lawyers and police officers) enrolled in a Diploma course in Forensic Toxicology and Judicial Expertise. Blood specimens were analyzed by the Widmark/Microburette and Conway microdiffusion methods. The following information was recorded: participant demographics (sex, weight, smoking status, fasting or fed); drinks consumed and percentage of alcohol (Garapiña 5%, 6% Chicha, Guarapo 7.5%, 5% Beer, Rum 35%, 40% Singani, Whisky 40% and 50% Fernet); clinical assessment; and ethanol amount in mL transformed into grams of ingested alcohol.

Results and Conclusions: Blood alcohol concentration, by type of beverage consumed, visual observation of each subject (including breath alcohol, presence of impaired behavior, state of consciousness), and patient demographics were correlated. Blood alcohol concentrations by the Widmark and microdiffusion methods were: 0.0 g/L to 4.80 g/L. As previously reported, after ingesting the same quantity of alcohol, blood alcohol levels were higher in women than men. Blood alcohol was higher in fasting subjects than in those who had eaten. We also observed a lower alcohol concentration in the blood of those who smoked compared to those who did not smoke at the time of drinking. We also verified the clinical observations for each person with different blood alcohol concentrations. We related these to the references in the table developed by Dr. Manuel Repetto, who described in "Toxicology of Ethyl Alcohol" the features and clinical status of subjects according to the corresponding alcohol level.

Keywords: Biochemical Methods, Enzymatic Methods, Alcohol, Widmark Method

Ethyl Glucuronide Concentrations in Pulverized and Cut Hair Samples

Maria Elena Albermann*, Frank Musshoff and Burkhard Madea
Institute of Forensic Medicine, University of Bonn, Bonn, Germany

Objectives: According to the German law in certain situations, probands have to document alcohol abstinence in driving-license regranting. A negative ethyl glucuronide (EtG) result in a proximal segment of scalp hair, maximum 3 cm, is sufficient to fulfill this requirement in Germany. Within the last year, our laboratory analyzed more hair samples for this purpose than in the past. Sample preparation, especially cutting the hair with scissors, is a very time-consuming process. Grinding the hair samples with a mill would not only save an enormous amount of time but would also lead to more homogenous matrices. However, studies have shown that pulverized hair samples can have higher concentrations of matrix compounds in the hair extract than cut hair. We compared analyses of hair samples tested positive for EtG when hair was cut with scissors to samples ground with a mill to determine if the latter method had more matrix effects and to determine which method gave most reliable results.

Material and Methods: Forty positive ($c_{\text{EtG}} > 10$ pg/mg) and six negative ($c_{\text{EtG}} < 1$ pg/mg) hair samples originating from driving ability diagnostics and from volunteers were included in this study. After washing the hair samples, one half was cut with scissors and the other half was pulverized. In sixteen cases, less hair was available so the whole hair segment was pulverized and the measured EtG concentration was compared with the previously determined result. A FastPrep Automated Homogenizer (MP Biomedicals) was used, operated with steel balls (\varnothing 3 mm). The following extraction procedure was identical. An aqueous hair extract was injected directly in the LC-MS/MS without further purification.

Results: Both preparation procedures were performed without any problems. Concentrations between 11 and 140 pg/mg (mean: 43 pg/mg, median: 29 pg/mg) were determined in hair samples cut with scissors. In pulverized hair samples EtG concentrations between 13 and 175 pg/mg (mean: 59 pg/mg, median: 45 pg/mg) were measured.

Conclusion: In pulverized hair samples the EtG concentrations differed from the concentrations measured in cut hair samples between -4.5 and +95 pg/mg (mean: 17 pg/mg, median: 11 pg/mg). This corresponds to a deviation of 5 – 188%. Only four hair samples had lower EtG concentration in pulverized (-0,8 – -4.5 pg/mg) vs cut samples. A Wilcoxon-Test (95% confidence interval) showed a highly significant increase of the EtG concentrations in pulverized hair samples. This indicates a better extraction yield as a result of the more homogenous and finely ground hair matrix. EtG could not be detected in any pulverized hair sample, which was previously tested negative for EtG in the cut form. This indicates that EtG is not formed by pulverization. Higher background noise or a larger number of signals from the matrix were not observed when analyzing pulverized hair samples. These results show that EtG concentration is higher in pulverized hair compared to cut hair due to better recovery. We recommend grinding the hair with a mill for EtG analysis.

Key Words: Ethyl Glucuronide, Hair, Pulverizing Versus Cutting

The Effects of Chemical Treatments on the Detection of the Alcohol Consumption Markers Ethyl Glucuronide (EtG) and Fatty Acid Ethyl Esters (FAEE)

Donna May Rowsell* and Katie Laura Lawrence
Concateno TrichoTech, Cardiff, United Kingdom

Introduction: Alcohol is the most readily available and the most commonly abused drug in the UK and it is estimated that 1 in 17 people (6.4%) in Great Britain are alcohol dependent. According to the World Health Organisation (WHO) and a literature survey, chronic excessive alcohol drinking corresponds to consumption of greater than 60 grams of pure ethanol per day during a period of several months. The Society of Hair Testing (SoHT) recognises that there is a need to establish chronic excessive alcohol consumption in clinical and forensic matters, and recommends the identification of the alcohol biomarkers such as EtG and FAEE for this purpose. Each marker is incorporated into the hair via different processes; EtG is thought to be mainly incorporated into the hair via sweat and FAEE incorporated into the hair via sebum.

Objectives: Previous research has indicated that chemical treatments such as dyes and bleaches can damage hair so that it holds less EtG or FAEE than it would otherwise. The objective of this study was to further investigate whether the use of chemical treatments can affect the detection of EtG, FAEE or both EtG and FAEE in hair samples.

Methods: From the beginning of January 2011 to the end of March 2011 Concateno TrichoTech tested 405 samples of hair requiring analysis for evidence of chronic excessive alcohol consumption. The hair samples were analysed using the confirmation techniques gas chromatography with mass spectrometry (GC-MS) for evidence of EtG, and GC-MS and headspace solid phase micro-extraction (HS-SPME) for evidence of FAEE. Deuterated EtG and deuterated FAEE were used as internal standards.

Results: Of a total of 405 samples, 185 (46%) declared the use of a hair treatment, 155 (38%) declared no use of a hair treatment and the remaining 65 (16%) did not supply any information regarding a hair treatment. For information, where a hair treatment has been declared, 88% of these donors were female. Of these 185 treated hair samples, 153 (83%) were negative, 12 (6%) were positive for chronic excessive alcohol consumption, and 20 (11%) proved inconclusive. Of the 155 non-treated hair samples, 113 (73%) were negative, 19 (12%) were positive and 23 (15%) proved inconclusive. We define an inconclusive result as one where only one of the alcohol biomarkers is detected and the other is not detected. Of the 20 inconclusive results where a hair treatment was declared, 17 (85%) were FAEE detected with EtG not detected, and 3 (15%) were FAEE not detected with EtG detected. Of the 23 inconclusive results where no hair treatment was declared, 14 (61%) were FAEE detected with EtG not detected, and 9 (39%) were FAEE not detected with EtG detected. When evaluating the 38 samples that were positive for chronic excessive alcohol consumption (i.e. FAEE detected and EtG detected) 23 (61%) were males and 15 (39%) were females.

Conclusion: This study demonstrates that the use of chemical treatments on a hair sample has a greater effect on reducing the amount of EtG detected than the amount of FAEE detected. This reinforces the current scientific opinion of chemical hair treatments on hair samples. This study also shows that a chemically treated hair sample can be used with corroborating tests to determine chronic excessive alcohol consumption but should still be interpreted with caution and not used in isolation.

Key Words: Hair, Alcohol, Chemical Treatment

Influence of Age, BMI and Seasonal Effects on Ethylglucuronide Concentration in Hair

A. Salomone*¹, V. Pirro^{1,2} and M. Vincenti^{1,2}

¹Centro Regionale Antidoping e di Tossicologia "A. Bertinaria", Orbassano, Turin, Italy; ²Dipartimento di Chimica Analitica, Università degli Studi di Torino, Turin, Italy

Objectives: Ethylglucuronide in head hair (HEtG) has become the most accredited marker to prove chronic alcohol abuse, although some warnings about the general applicability of this determination have been recently raised. We recently published conclusions about the reliability of utilizing alternative keratin sources (pubic, axillary or chest hair) whenever head hair is not available [1]. In this study, we investigated some of the other potential discriminating factors, in order to understand the possible sources of individual variability and to regulate and standardize HEtG determinations in the forensic context. Our objective was to evaluate the HEtG level distribution in the selected population, as classified according to personal and objective parameters, including (i) age, (ii) body mass index, and (iii) season of hair growth, not to their alcohol consumption. The experimental results were interpreted by statistical analysis, on the assumption that large population data-sets will provide similarly-shaped distributions, leveling off the specific contribution of individual alcohol consumption.

Materials and Methods: Hair samples were collected from medical commissions for driving licences located in Northern Italy. These medical commissions examine a broad range of drivers requesting to undertake a medical examination to obtain the renewal of their suspended or expired licence. HEtG was determined by HPLC-MS/MS operating in SRM mode.

Results: The non parametric Kruskal-Wallis test was applied to compare HEtG level distributions, for all samples showing a measurable concentration (>10 pg/mg; N=575 for age evaluation; N=225 for BMI evaluation). A significant distribution difference based on age was observed. The percentage of hair samples classified as positive ranged from 2.9% in the 18-30 years old group (HEtG median=17.0 pg/mg, IQR=9) to 22.0% in the group over 40 years old (HEtG median=30.0 pg/mg, IQR=41). In contrast, BMI appears not to produce statistically significant differences among the groups, although the uneven dimension of examined populations prevents definitive conclusions at present. Lastly, the season of hair growth was evaluated. Hair samples (N=816) were initially selected on the basis of their length (between 1-3 cm) and period of collection (March, June, September and December), and subsequently divided into four groups, basically corresponding to hair growth in winter, spring, summer and autumn. Seasonal trends were observed, with HEtG peak levels in winter and minimum levels in summer (percentage of positive samples in winter 2009, summer 2010 and winter 2010 were, respectively, 22.14%, 8.93% and 16.50%), suggesting, as possible sources of HEtG concentration bias, differences in sweating, frequency of hair washing or alcohol intake, depending on the sampling season.

Conclusion: While the trustworthiness of HEtG determination to assess chronic alcohol consumption and distinguish heavy from social drinkers is unquestionable, further studies are needed to understand the real degree of biological inter-individual variation and to confirm or exclude any possible source of bias, leading to more realistic uncertainty factors and possibly differentiated cut-off levels.

References:

1. V. Pirro, D. Di Corcia, S. Pellegrino, M. Vincenti, B. Scutteri, A. Salomone, A study of ethyl glucuronide in different keratinic matrices, *Forensic Science International*, **2011**, DOI:10.1016/j.forsciint.2011.03.026.

Key Words: Ethylglucuronide, Statistical Elaboration, Alcohol Abuse

Alcohol Intoxication During a Drinking Experiment Based on Widmark's Equation

Heike Gnann^{*1}, Jörg Eschbach², Wolfgang Weinmann³ and Annette Thierauf¹

¹Institute of Forensic Medicine, University Medical Center, Freiburg, Germany; ²Department of Anaesthesiology, University Medical Center, Freiburg, Germany; ³ Institute of Forensic Medicine, Medical Faculty, University of Bern, Bern, Switzerland

Objectives: In the last century, several equations and mathematical models have been developed to calculate blood ethanol concentrations (BAC) from the amount of ingested ethanol and vice versa. The most common one in the field of forensic sciences is Widmark's equation. This equation is formed using the amount of absorbed ethanol (A), the body weight (p) and the so called Widmark factor (r): $BAC = A / p \times r$. In the following study about alcohol consumption markers a remarkable discrepancy between the generated and measured BAC was observed.

Materials and Methods: 11 voluntary test persons (5 females and 6 males, 19–75 years of age, average age 30.5 years) with normal alcohol consumption behaviour were asked to drink within one hour an amount of vodka leading to an expected blood ethanol concentration of approximately 1.2 g/kg. The volume of vodka was individually calculated using Widmark's and Watson's equation.

Ethanol concentrations in blood were measured by HS-GC-FID (Headspace gas chromatography/flame ionisation detector) using t-butanol as internal standard and with an ADH-based method (DRI alcohol dehydrogenase assay, Thermofisher Scientific, Dreieich, Germany).

Results: Maximum BACs of ten of the 11 test persons ranged from 0.99 to 1.41 g/kg (82.5 % -117.5 % of the generated amount of 1.2 g/kg). However, one test person reached a BAC of 1.83 g/kg, 152.5 %. All test persons showed inconspicuous serum levels of carbohydrate deficient transferrin and gamma-glutamyltransferase. The test person with the highest BAC of 1.83 g/kg one hour after drinking 281 mL vodka (40 Vol-%) was a 75-year-old, healthy man with a body height of 1.78 m and weight of 76 kg (BMI 24.0 kg/m²). As a result of this, the high BAC, he showed substantial signs of intoxication. He was dizzy and vomited and his blood pressure was decreased. In contrast, another male participant in the drinking experiment (29 years old, with a comparable BMI of 24.3 kg/m², body height 1.72 m, weight 72 kg) drank 270 mL of vodka resulting in a maximal BAC of 1.35 g/kg. However, he showed no visible signs of alcohol intoxication.

Conclusions: A great discrepancy of the generated and measured BAC was observed in a drinking experiment for investigating alcohol consumption markers. A possible reason for this unexpected high BAC of the older man could be the age and the age dependent lower body content. This factor is not considered in Widmark's equation. Although this equation to predict blood alcohol predicted the maximal blood alcohol concentration fairly well, this drinking experiment shows that caution is advised when using a mathematical model for the calculation of blood ethanol concentrations.

Key Words: Alcohol, Widmark's Equation, Intoxication

In vitro formation of phosphatidylethanol homologues after incubation with d₆-ethanol

Alessandro Nalesso*, Marianna Tucci, Rossella Snenghi, Claudio Terranova, Guido Viel, and Santo Davide Ferrara
Forensic Toxicology and Antidoping Laboratory, Department of Environmental Medicine and Public Health, University Hospital of Padova, Via Falloppio 50, I-35121 Padova, Italy

Introduction: The alcohol biomarker phosphatidylethanol (PEth) forms in cell membranes in the presence of ethanol by the catalytic action of the enzyme phospholipase D on phosphatidylcholine. PEth is not a single molecule but a group of phospholipids, named homologues, with a common polar phosphoethanol head group on which two fatty acid moieties are attached at positions sn-1 and sn-2. Previously published literature (Varga A - J Lab Clin Med-2002, Aradóttir S - Alcohol Alcohol. - 2004) has demonstrated that incubation of fresh blood with ethanol causes the neo-formation of PEth. At the moment, there are no data available on the in vitro formation of the various Peth homologues and on their relative distribution.

Objectives: The study investigated the formation of deuterated-Peth homologues and their relative distribution in fresh blood samples after incubation with d₆-ethanol.

Methods: Freshly collected blood samples were incubated (12 – 48 h) with variable concentrations of d₆-ethanol (1-4 g/L). Sterile 5-mL blood collection tubes with tight lids were used to prevent evaporation of ethanol. Reactions were carried out without shaking at 37°C. Ethanol concentrations were checked during and after incubation and no losses were observed. Blood lipids were extracted according to the procedure of Gnann et al., with some minor modifications. Whole blood (0.3 mL) fortified with internal standard (phosphatidylethanol, 0.5 µM) was diluted with water (0.3 mL) and briefly ultrasonicated; 2-propanol (0.8 mL) and hexane (1.2 mL) were added dropwise under vortex-mixed agitation. Once evaporated, the organic layer was redissolved with isopropanol (50 µL) and diluted with methanol (150 µL). Analysis was performed on a LTQ-Orbitrap mass spectrometer (Thermo, San Jose, CA, USA) equipped with an electrospray ionization (ESI) source operating in negative ion mode. Chromatography was performed at 55°C on a Zorbax XDB C18 column (50×4.6 mm, 1.8 µm particle size; Agilent Technologies, Palo Alto, CA, USA) with acetonitrile (A), 10 mM ammonium acetate in water (B) and 2-propanol (C) as mobile phases, at a flow rate of 200 µL/min.

Results: Mass tolerance of 4 ppm led to effective identification of d₅-PEth homologues, based on the exact mass of the deuterated Peth calculated from the postulated molecular structure. The chromatographic behaviour of the neo-formed homologues was virtually identical to the corresponding non-deuterated compounds. The first traces of d₅-PEth deuterated homologues were detectable after a few hours of incubation. According to the relative ratio of the area of the internal standard, the most abundant identified deuterated PEth homologues were d₅-PEth 16:0/18:1, d₅-PEth 16:0/18:2, d₅-PEth 16:0/18:1 and d₅-PEth 18:0/18:2. The total number of detectable species was related to both incubation time (12 - 48 h) and concentration of d₆-ethanol.

Conclusions: A novel approach to evaluate the in vitro formation Peth homologues has been established. Incubation of freshly collected blood samples with d₆-ethanol led to the appearance of deuterated phosphatidylethanol homologues, which were easily differentiated from non-deuterated ones by high resolution mass spectrometry. Further research will be necessary to compare the distribution pattern of neoformed deuterated Peth homologues with the distribution pattern of Peth homologues present on blood of social and heavy drinkers. If a good match between these distributions will be verified, application of neoformation with d₆-ethanol on a wide scale will contribute to define normal, abnormal, and low occurring Peth homologues distributions on general population.

Key Words: Phosphatidylethanol, Alcohol Abuse, d₆-Ethanol, High Resolution Mass Spectrometry

P275

WITHDRAWN

An Analytical Method for the Determination of Testosterone and Epi-Testosterone by Liquid Chromatography-Tandem Mass Spectrometry

Adam Latawiec¹, John McFarlane² and Adrian Taylor^{1*}

¹AB SCIEX, Concord, ON, Canada; ²AB SCIEX, Foster City, CA, USA

Introduction: The measured ratio of testosterone to epi-testosterone has been useful for detecting the exogenous administration of testosterone, often used to enhance athletic performance. Epitestosterone, an inactive epimer of the hormone testosterone, is typically present in approximately equal concentrations as testosterone in urine, and the mean testosterone/epitestosterone (T/E) ratios in athletes is generally less than 2.0. The World Anti-Doping Agency has established a standard for T/E ratios of 4.0 or greater as indicative of possible exogenous testosterone administration. In the work presented here, we have developed an analytical method for measuring urine and serum levels of testosterone and epi-testosterone by liquid chromatography-tandem mass spectrometry.

Methods: Analytical standards were obtained from Cerilliant, as 1.0 mg/mL solutions in acetonitrile, and spiked into blank serum matrices. 100 μ L of human serum in a polypropylene microcentrifuge tube was treated with a solution of 10 ng/mL Testosterone-d3 in methanol. The resulting mixture was vortex mixed for approximately 30 seconds and centrifuged on an Eppendorf Model at 14000 rpm for 10 minutes. The supernatant was transferred to a 300 μ L polyethylene HPLC vial and a 50 μ L aliquot was analyzed by 2D HPLC with tandem mass spectroscopy detection.

The HPLC system consisted of a Shimadzu LC-20AD system. The dual pumps were operated in the isocratic mode and the mixing valve was bypassed to afford 2 separate LC flows. The first isocratic flow follows the injector path onto the POROS column and the material eluting from the POROS column is diverted to waste. After a certain time, the diverter valve is switched and material is transferred to the reverse phase analytical column. The diverter valve is again switched and the target materials are eluted from the analytical column using the second binary pump. This affords complete baseline separation of the testosterone and epi-testosterone from the serum sample in a run time of 7 minutes.

Calibration was performed using double charcoal stripped human serum samples spiked with varying amounts of testosterone and epi-testosterone in a range of 0.10 to 50 ng/mL

Results and Conclusion: Calibration curves for testosterone and epi-testosterone were linear with R^2 values of no less than 0.998 and 0.995 respectively. Spike recoveries in double charcoal stripped serum at both low (0.5 ng/mL) and high (20 ng/mL) levels ranged between 90% to 115% with %CV between 5-10% (10 replicates intra day).

Male serum samples were obtained from commercial suppliers and were analyzed neat and following spikes of varying amounts of testosterone or epitestosterone. Excellent recoveries of spiked amounts were observed at testosterone/epitestosterone ratios between 0.5 to 5.0 with LOD of 60 pg/mL. We believe that the sensitivity and accuracy of this method will allow it to be deployed effectively in sports doping laboratories.

Key Words: Epitestosterone, Testosterone, Epimer Chromatographic Separation

GC-GC with Heart-Cutting as a Simple and Rapid Sample Purification Method for GC-C-IRMS

Alan Brailsford*, Ivana Gavrilović, David Cowan and Andrew T. Kicman
Drug Control Centre, King's College London, UK

Objectives: The use of gas chromatography-combustion-isotope ratio mass spectrometry (GC-C-IRMS) for the analysis of androgens in urine requires good sample preparation for reliable measurements, but current approaches such as LC-fraction collection can be time consuming. Furthermore, the lack of analyte identification of the eluents in IRMS (post GC analytes are combusted) has been a focus of several major challenges to IRMS data in high profile sports cases. As part of a World Anti-Doping Agency grant, the hypothesis was tested that emerging technologies such as capillary flow (CF) technology and GC+GC would provide an improved system for the analysis of urinary steroids by IRMS (Micromass, Isoprime). The aims were firstly, to target testosterone (T), rather than its metabolites; secondly, to analyse underivatized steroids (to avoid the additional ^{13}C contribution from the derivative) and thirdly, to provide simultaneous peak identification.

Materials and Methods: In order to achieve better sensitivity (5 fold), a large volume injection system was installed (Gerstal cooled injection system (CIS)). To facilitate analyte identification a simple reliable system has been developed using CF, where a portion (< 20%) of the eluent from the GC has been diverted to a scanning MS (Agilent MSD). To analyse underivatized steroids without time-consuming sample preparation a GC+GC approach was investigated. More selective/polar GC columns are unsuitable for GC-C-IRMS analysis as they produce too much column bleed to allow direct coupling to the C-IRMS furnace. However, we have further implemented CF, in this instance a Deans switch, to heart-cut the eluent from the first GC at the appropriate times into the second GC (an Agilent low thermal mass oven (LTM)). This approach allows the use of highly selective (6% cyanopropyl/phenyl) columns to separate the various steroids in the first dimension, while a more conventional column (i.e. (5%-phenyl)-methylpolysiloxane) in the second dimension focuses the selectively cut analytes into narrower peaks for IRMS analysis, thus maintaining overall sensitivity.

Results and Conclusion: This approach has been applied for the urinary (5 mL) analysis of T (around 50 ng/mL), with the delta value (-27.8 ‰) being clearly distinct from an endogenous reference marker (-22.5 ‰), thus indicating T as being of exogenous origin. The simultaneous analysis by the quadrupole mass spectrometer yielded a full scan spectrum of testosterone, facilitating peak identification.

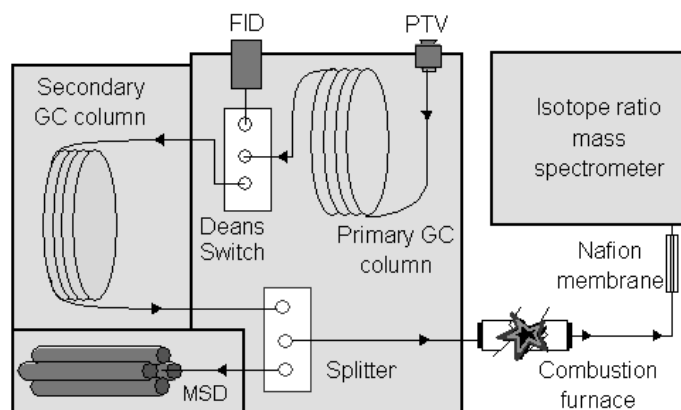

Simplified schematic of the modified PTV-GC+GC-MSD-C-IRMS instrument

Key Words: IRMS, Steroids, GC+GC

The Effect of Ethanol Ingestion on the Reliable Detection of Testosterone Doping in Sports

Joana Lobo Vicente*, David A. Cowan and Andrew T. Kicman

Department of Forensic Science & Drug Monitoring, Drug Control Centre, King's College London, London, England, UK

Objectives: Testosterone (T) administration is prohibited in sports by the World Anti-Doping Agency (WADA). With T administration, the ratio of T to its inactive stereoisomer, epitestosterone (E), increases. WADA accredited laboratories are expected to undertake further analysis on any urine sample collected from an athlete with a T/E greater than 4.0¹. Studies on a few volunteers^{2,3} have shown that acute alcohol consumption (2.0 g/kg) may increase this ratio in some women but there is little published data of this effect. This study aims to confirm the increase in T/E ratios and the possible impact of the increase on the use of T/E ratios assessed by the WADA value of 4.0. The female population's 97.5 percentile of T/E is < 2.65⁴ and an individual athlete's ratio could be less due to detection limits of T doping.

Methods: Alcohol (8 units) was ingested by 10 women (0.4 – 1.1 g/kg) over 1 h. A urine sample was collected prior to drinking (acting as a control) and then hourly post-alcohol ingestion until 10 h, then at 24 h, 48 h and 72 h. Urinary and serum luteinizing hormone (LH) were measured by immunoassay, and T/E urinary ratios were obtained by GC/MS analyses.

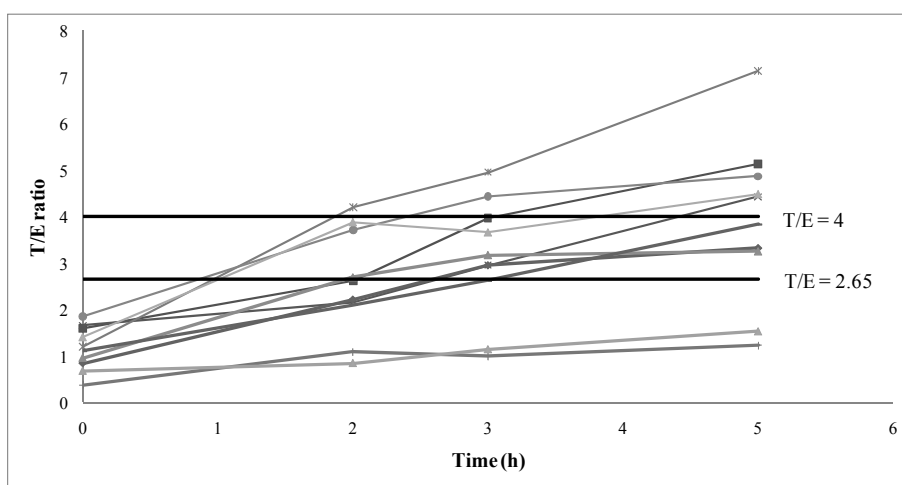

Graph 1. T/E ratio at selected time collection points following alcohol ingestion (8 units) in 10 females.

Results and Conclusions: An increase in urinary T/E following alcohol intake was observed in all 10 females. In 8, this increase was above the 97.5 percentile (2.65) and, in 5 subjects, it was evidentially significant (T/E > 4.0) (Graph 1). No increase in urinary or serum LH was observed. This study confirms that, at least in females, a marked increase in urinary T/E following acute alcohol intoxication may occur. Testing urine samples for ethanol, and its glucuronide or sulfate metabolites, could justify removal of a T/E value from an individual's passport data thereby improving the dataset and the reliability of detection of T doping.

References:

- (1) World Anti - Doping Agency **2004**.
- (2) Karila, T.; Kosunen, V.; Leinonen, A.; Tahtela, R.; Seppala, T. *Journal of Chromatography B* **1996**, *687*, 109-116.
- (3) Falk, O.; Palonek, E.; Bjorkhem, I. *Clinical Chemistry* **1988**, *34*, 1462-1464.
- (4) Van Renterghem, P.; Van Eenoo, P.; Geyer, H.; Schanzer, W.; Delbeke, F. T. *Steroids* **2010**, *75*, 154-163.

Keywords: Alcohol, Testosterone/Epitestosterone Urinary Ratio, Doping

Importance of Packaging Analysis in Cases of Drug Facilitated Crimes

F. Aknouche*, E. Guibert, R. Buti, M. Eyraud, and V. Maignant
Laboratoire BioMed, Antibes, France

Objective: To demonstrate the importance of collecting objects of evidence to potentially aid in the analysis of biological samples regarding drug facilitated crimes.

Case Reports: In one case, a female victim complained about vaginal and anal pains following an evening with friends. According to her account, during the evening, she absorbed two or three tablets and could only remember having seen pink and black prior to her losing consciousness. The blood of the victim and suspect were collected as well as evidence at the scene including tumblers, small dishes, and glasses. In a second case, during an electronic festival of music on a Mediterranean beach in the summer of 2010, the police seized from a man, known to be a seller, a plastic syringe containing milliliters of a liquid contained in a flask of clonazepam (drinkable solution of 2.5 mg/mL, ROCHE). In a third case, evidence was collected and analyzed from various containers found in a hospital room where an ill male was strangled by his wife: a bottle of Perrier and Schweppes, a tumbler, and an empty yogurt container. In addition to the various evidence containers collected in all three cases, biological specimens were also collected and analyzed.

Methods: A method of screening was applied with the aim of revealing any traces of xenobiotics in the various samples. Toxicological analysis used to detect the psychotropic molecules in the various packagings collected as evidence utilized a gas chromatography (Focus GC with column TR5MS, Thermo Fisher Scientific, Courtaboeuf, France) coupled with a mass spectrometer (Polaris Q, Thermo Fischer, Courtaboeuf, France) with XCalibur software. The biological samples, drink containers, yogurt, and bottles were analyzed with a double liquid-liquid 1-chlorobutane extraction. The dry extract was reconstituted with chloroform. Packagings (tumblers, glasses, syringe) were rinsed with chloroform, concentrated, and analyzed. The liquid contained in the flask was analyzed by several liquid-liquid extractions using 1-chlorobutane, chloroform, and methanol.

Results: In the first case involving allegations of drug facilitated sexual assault, nordiazepam was detected in the blood of the victim. The suspect was under the influence of cannabis at the time of the blood draw. Two of the seized tumblers contained a dry whitish residue which was determined to be nordiazepam. The seized small dish contained delta-9-tetrahydrocannabinol (THC), cannabinol (CBN), and cannabidiol (CBD). In the second case, analysis of the transparent liquid sold in the free syringe during a festival was identified as GBL (gamma-butyrolactone). In the third case, lorazepam was identified in the yogurt container and in the gastric contents of the decedent but the only conclusion that could be drawn was that lorazepam was ingested by the decedent prior to strangulation.

Conclusion: Drug facilitated crimes occurred in all cases and the last case was ruled a homicide. Authorities in charge of investigating crimes must consider the importance of collecting containers or packaging as sources of evidence in order to demonstrate the administration of incriminated substances.

Key Words: Drug Facilitated Crime, Non-Biological Analysis

Detection of GHB in Drug-Facilitated Sexual Assault Products on the Thailand-Myanmar Border**Piyamas Suriya*¹**, Prapatsorn Tipparat¹ and Kitti Chantaksinopas²¹Regional Medical Sciences Centre 10, Department of Medical Sciences, Chiang Mai, Thailand; ²Chiang Rai Provincial Public Health Office, Chiang Rai, Thailand

Introduction and Objectives: *Gamma*-Hydroxybutyrate (GHB), an illegal substance in the United States, Canada, Australia and most European countries, is abused recreationally and is used in drug-facilitated sexual assaults. In Thailand, GHB is regulated as a controlled psychotropic substance. During 2009-2010, GHB was identified in seized materials from 3 criminal cases; one sexual assault case in downtown Chiang Mai and two cases in which GHB was detected in sexual enhancement products sold at the Mae Sai market on the Thailand-Myanmar border. Surveillance of the availability of GHB-containing products on the Thailand-Myanmar border is essential for both law enforcement and health reasons.

Materials and Methods: Ten suspected GHB-containing sexual enhancement products were obtained from Myanmar street vendors. Eight of these were aluminum packets with sexually explicit drawings containing GHB powder. The other two samples were a clear solution in a glass bottle and a packet of chewing gum. Identity testing was conducted using 3 different techniques: a color test, headspace gas chromatography with flame ionization detector (HS-GC-FID), and high performance liquid chromatography with UV detector (HPLC-UV). All tests included comparison to a GHB standard and its lactone form, gamma-hydroxybutyrolactone (GBL). The color test was performed using a mixture of bromocresol purple, bromothymol blue and modified Schweppes solutions. GHB gave a pale to dark purple color whereas GBL gave a yellow color as expected from tests with known solutions. Prior to analysis by HS-GC-FID (Rtx[®]-volatiles column 30m × 0.53mm, 2µm, oven temperature: 50 °C hold for 5 min, ramp 15 °C to 200 °C hold for 5 min, detector temperature 220 °C), GHB was partially converted to GBL by heating under acidic conditions. The identification of GBL in the confiscated samples was performed by comparison of its retention time to the standard.

Results: The results showed that the GBL levels in acid-treated samples and in acid-treated GHB standard were significantly higher than the non-treated ones. In addition, confirmation testing was performed by HPLC-UV on a C₁₈ column with a phosphate buffer pH 3.0:methanol (70:30) mobile phase. The UV detection wavelength was 215 nm. All samples had similar retention times and an absorbance at 215 nm, confirming the presence of GHB.

Conclusion: This study speculates that the GHB-containing products are available via street vendors on the Thailand-Myanmar border.

Key Words: GHB, Sexual Enhancement Products, Thailand-Myanmar Border

Detection of GHB and Related Substances in Urine Samples by Enzymatic Screen Followed by UPLC-MS/MS Confirmation

Thomas Keller*¹, Andreas Preidel², Andre Scholer³, Torsten Arndt⁴, and Michael Boettcher²

¹Forensic Medicine, University Salzburg, Austria; ²MVZ fuer Mikrobiologie, Labordiagnostik und Hygiene Dessau GmbH, Germany; ³Bottmingen, Switzerland; ⁴Bioscientia, Institut fuer Medizinische Diagnostik GmbH, Ingelheim, Germany

Objectives: Gamma-hydroxybutyric acid (GHB, “Liquid Ecstasy”) is increasingly abused as a recreational drug due to its mood-enhancing effects. Owing to its incapacitating properties, the drug is also used in drug-facilitated crimes. The solvents gamma-butyrolactone (GBL) and 1,4-butane-diol (1,4-BD) are also abused because of their biotransformation to GHB. For rapid screening of GHB in urine samples, we established an enzymatic assay (EA) and for confirmatory analysis, an UPLC-MS/MS method was developed; the UPLC-MS/MS method can also be applied to test liquids containing GBL and 1,4-BD. Both methods were compared and checked for interferences with the endogenous compounds beta-hydroxybutyric acid (BHB) and alpha-hydroxybutyric acid (AHB). Endogenous GHB levels, as a basis for future cut-off considerations, were determined in a defined population.

Methods: The EA of GHB was conducted on a Hitachi 912 according to the manufacturer (Buehlmann). UPLC-MS/MS (Waters) quantification of GHB and GBL and qualitative detection of 1,4-BD, AHB and BHB was performed after isocratic separation on a 1.8- μ m HSS T3 column (2.1 x 150 mm) within 6 min. Data were acquired in positive ionization mode and three transitions were recorded for GHB and GHB-D6, BHB, 1,4-BD and two for GBL, GBL-D6 and AHB. For sample preparation, 100 μ L urine was diluted with 300 μ L methanol containing 1 μ g GHB- and GBL-D6. After centrifugation, the supernatant was diluted 2-fold in water with 10 μ L being injected into the UPLC. Equidistant 10-point calibration from 0.1 to 1.0 mg/L was used for GHB and 8-point calibration from 3 to 10 mg/L for GBL giving the following LODs/LOQs: GHB 0.22/0.41 mg/L, GBL 1.38/3.83 mg/L. Working calibration range was up to 50 mg/L. Intra- and inter-assay CVs for GHB were from 2.7% to 4.3% with a bias from 5.2 to 5.6%. Quality control for both methods is routinely performed at control levels of 7.50/12.50 mg/L (FDT -25%/FDT +25%, ACQ Science) and 13.8/73.7 mg/L (low/high control, Buehlmann). Volunteer urine samples from 100 females (3-85 years) and 100 males (3-81 years) were investigated for endogenous GHB.

Results: Both methods show excellent reproducibility with the four control samples (n = 13 to 28 series): CVs range from 4.9 to 10.8% and bias from -8.4% to 10.7%. AHB and BHB showed no “cross-reactivity” in the EA up to 400 mg/L while GBL produced a 32 mg/L signal. AHB and BHB were not observed in concentrations above 0.5 mg/L with UPLC-MS/MS in control samples. For recovery studies, 20 GHB negative urine specimens were spiked with 10 mg/L GHB resulting in a mean value of 11.2 mg/L (CV 9.9%) with UPLC but 19.6 mg/L (CV 27.6%, range 11.7 to 33.5 mg/L) with the EA which had results correlating strongly with creatinine ($r^2 = 0.910$; 10 samples >200 mg/dL creatinine). However, when GHB positive samples were compared (n = 20, 17 samples >100 mg/L) both methods showed good agreement (slope = 0.987, $r^2 = 0.987$). From these positive samples, nine contained GBL (5.0 to 64.1 mg/L). From the 100 female urine samples, 63 were >0.5 mg/L GHB (0.51 to 5.29 mg/L) with the EA but from these only 14 samples were >0.5 mg/L with UPLC-MS/MS (0.53 to 1.51 mg/L). One sample was 0.59 mg/L with UPLC and <0.5 mg/L with the EA. From the 100 male urine samples 71 were >0.5 mg/L GHB (0.51 to 15.70 mg/L) with the EA but from these only 5 samples were >0.5 mg/L with UPLC-MS/MS (range 0.54 to 0.98 mg/L).

Conclusions: No concentrations of endogenous GHB above 2 mg/L were observed in urine samples. The suggested cut-off for GHB analysis with the enzymatic screening method is 10 mg/L.

Key Words: Endogenous GHB, Cut-Off, UPLC-MS/MS

Gas Chromatography- Mass Spectrometry Analysis of Benzodiazepines in Spiked Drinks under Different Storage Conditions

Lata Gautam* and Sarah Sharratt

Department of Life Sciences, Anglia Ruskin University, Cambridge, CB1 1PT, UK

Introduction and Objectives: Drug facilitated sexual assault (DFSA) is one of the most prevalent crimes in the UK. According to Scott-Ham and Burton (2005), the Forensic Science Service (FSS) in the UK has to deal with about 500 claimed DFSA cases annually. Only a handful of studies have been carried out to investigate the veracity of claimed DFSA cases in the UK (Scott-Ham and Burton, 2005) and in the US (ElSohly and Salamone, 1999; Slaughter, 2000; Hindmarch, *et al.*, 2001). All of these studies have shown that alcohol is the major contributing factor in DFSA. Scott-Ham and Burton (2005) reported benzodiazepines in 9% of 1014 studied cases. As DFSA cases are generally reported late, the usual matrix of drug analysis becomes less significant. Consequently the analysis/stability of suspected drinks (in case they are collected) becomes important; this topic has not been fully investigated.

Materials and Methods: In this research, flunitrazepam, temazepam and diazepam were spiked into a variety of beverages that were selected to represent common drinks consumed by women in the age ranges of 16-24, including alcopop, spirit, white wine, normal strength beer and a fruit based non-alcoholic drink. These 'spiked' drink samples were then used to investigate the detection, recovery, stability and quantitation of benzodiazepines over a 25 day period. The analytes were isolated using liquid-liquid extraction with chloroform: isopropanol (1:1 v/v), diazepam-d5 and eicosane were used as internal standard. 50 μ L of BSTFA: TMCS (99:1) along with 50 μ L eicosane in ethyl acetate was then added before derivatization at 70 $^{\circ}$ C for 15 minutes. Samples were analyzed by GC-MS in EI mode. ZB1 column (30 m length, 0.25 mm ID, and 0.25 μ m thickness) was used with a 14:1 split injection.

Results: A linear detector response range was established (0.025–0.25 mg/mL for diazepam and temazepam, 0.05-1 mg/mL for flunitrazepam). The limit of detection was calculated as 0.571, 0.506, 0.714 ng and the limit of quantitation as 0.642, 0.714, 1.28 ng on column for these drugs respectively. The coefficient of variation was less than 10%. The individual drug recovery during extraction was >90%. Results from matrix blank showed the absence of interfering signals indicating the selectivity of the method. All three benzodiazepines were detected in the studied beverages at each time interval and storage condition. However, issues of stability exist with different beverages and storage conditions. To establish whether or not the difference was significant, Kruskal-Wallis U test was applied at 95% confidence level. In the case of temazepam, significant differences were found in all drinks tested at both storage conditions. Even though it was detected for 25 days, the concentration decreased with time. The stability of diazepam and flunitrazepam were found to be dependent on the drinks as well as storage conditions.

Conclusions: The conclusions from this study are that suspected drink samples should be analyzed as soon as possible after the seizure, an issue of which the police and forensic analysts should be made aware. This study also proves that GC-MS is suitable for the simultaneous detection and quantification of benzodiazepines.

Key words: DFSA, Benzodiazepines, Date Rape, GC-MS

Urine Toxicology Findings in Alleged Drug Facilitated Sexual Assault Cases Over a Six-Year Period (2005-2010) in the City and County of San Francisco, California

Chinyere M. Williams^{*,1}, Cecilia O. Medina¹, Glenda M. Easterling¹, Pavlos Karamanidis¹, Eric A. Ingle¹, Jonas E. Knight¹, Justin A. Volk¹, Ann M. Gordon¹ and Nikolas P. Lemos^{1,2}

¹Office of the Chief Medical Examiner, City and County of San Francisco, CA, USA; ²Department of Laboratory Medicine, School of Medicine, The University of California, San Francisco, CA 94143, USA

Objectives: The aim of this study is to review and present the urine toxicology results in all alleged drug facilitated sexual assault (DFSA) cases analyzed by the Forensic Laboratory Division of the Office of the Chief Medical Examiner of the City and County of San Francisco between 2005 and 2010, inclusively.

Methods: The Laboratory Division prepares and distributes evidence kits to be used in the collection of biological specimens in suspected DFSA cases. Urine collection kits are assembled in house and contain two 25-mL glass jars each containing 0.3 g of sodium fluoride preservative. The standard DFSA screening targets include ethanol and other volatile compounds, amphetamine and cocaine related stimulants, antidepressants, antihistamines, muscle relaxants, hallucinogens, opiates/opioids, and γ -hydroxybutyrate, all by means of ELISA and GCMS testing. To gather the data presented, a search of our computerized database was performed.

Results: A total of 670 suspected DFSA cases were analyzed in the time period of interest. The number of cases increased over the years from 94 cases in 2005 to 132 cases in 2010. The cases involved 588 alleged female victims (89%) and 70 alleged male victims (11%). Ages of the alleged victims ranged from 11 to 66 years, with a median of 26 years. In cases involving male victims, urine detection of alcohol (either alone or in combination with other substances) occurred in 34%, cannabinoids in 24%, stimulants in 36% (specifically, amphetamine-related in 21%, cocaine-related compounds in 24%), opiates/opioids in 17%, and antidepressants in 14%. Other drugs found in cases involving males included diphenhydramine (10%), methadone (7%), and doxylamine (4%). In cases involving females, urine detection of alcohol (either alone or in combination with other substances) occurred in 32%, cannabinoids in 24%, stimulants in 31% (amphetamine-related in 10%, cocaine-related compounds in 29%), opiates/opioids in 18%, and antidepressants in 16%. Other drugs found in cases involving females included diphenhydramine (8%) and doxylamine (3%). In addition, γ -hydroxybutyrate was detected in a total of 3 cases (1 male and 2 female).

Conclusions: This is the first study of its type in the City and County of San Francisco. Similar to previously reported studies, our data demonstrate that alcohol is the predominant toxicological finding in DFSA evaluations in the City and County of San Francisco. Cannabinoids, stimulants, antihistamines and sedative/hypnotics are also commonly encountered in this type of cases. Drugs that have been prominently publicized in the media and are often associated in the minds of laypersons as date rape drugs (e.g. GHB) are rarely seen in actual DFSA investigations in this jurisdiction. The data provided in this study suggests that the forensic and law enforcement communities would be more effective in their missions if they directed the training, awareness, and prevention away from media reported date rape drugs and, instead, focus more on the roles of alcohol, marijuana, and other commonly abused substances.

Key Words: Drug Facilitated Sexual Assault, Urine Toxicology, City and County of San Francisco

P284

WITHDRAWN

Profile of a Drunk Driver and Recidivism Risk Factors. Findings on the Prevalence and Development of Drunk Driving From Roadside Testing in Uusimaa, Finland 1990–2008

Maria Portman¹, Antti Penttilä², Jari Haukka², Peter Eriksson², **Teemu Gunnar^{1,*}**, Kimmo Kuoppasalmi¹ and Heikki Koskimaa³

¹National Institute for Health and Welfare, Helsinki, Finland; ²University of Helsinki, Hjelt Institute, Helsinki, Finland;

³National Traffic Police, Helsinki, Finland

Objectives: A study conducted in the province of Uusimaa in Southern Finland has shown that, one out of every 500 drivers has a blood alcohol concentration (BAC) above the legal limit of 0.05% while three have detectable BAC below the legal limit.

Materials and Methods: Overall, the prevalence of drunk driving did not change between 1990 and 2008. While it was lowest at 0.19% in 1991, 1999 and 2005 and highest at 0.28% in 2003, it varied randomly and showed no clear increasing or decreasing trends. On the other hand, the prevalence of drivers who had consumed alcohol but whose blood alcohol level remained below the legal limit, i.e. who had ‘had a few’, began to increase in the early 2000s and peaked at 1.11% in 2005. Since then, it has fluctuated between 0.5% and 0.7%.

Results and Conclusion: The study shows that a typical drunk driver is a man aged between 40 and 49 who has a driving licence and drives his own car, usually alone, with a blood alcohol level of 0.1%. He drives between 20,000 and 50,000 km per year. He is a skilled employee or junior salaried employee in permanent employment and is married or cohabiting. The percentage of women among drunk drivers (0.01-0.04 %) did not change during the period studied. Indeed, the profile of a typical drunk driver remained the same throughout the 18 years of the study period. The risk of drunk driving for women was less than one fifth of that for men. Divorcees and widow(er)s had a substantially higher risk of being caught driving drunk than married drivers.

Out of all first-time offenders, about 10% of whom are guilty of aggravated drunk driving (BAC \geq 0.12 %), half were later caught again drunk driving. The likelihood of a repeat offender being caught drunk driving again was 3.3 to 5 times higher than for a first offender. The risk also increased 2.5 times for drunk drivers with a BAC above the higher limit 0.12 % compared with drivers with a lower BAC. It is estimated that about half of all drunk drivers are repeat offenders.

Out of potential measures for preventing drunk driving (BAC \geq 0.05 %), the study findings favour measures such as amending the law to lower the blood alcohol threshold levels. In substance abuse assessment in health care, more attention should be paid to a person’s overall life situation in order to chart the risk factors (e.g. divorced man) for drunk driving. It is recommended that public officials consider expanded use of alcolocks through national legislation until such time as the automotive industry begins including them as standard equipment.

Key Words: Drunk Driving, Roadside Testing, BAC, Driver Profile, Southern Finland

Phenazepam in Finland

Pirkko Kriikku*¹, Lars Wilhelm², Ilkka Ojanperä³, Janne Rintatalo⁴, Jukka Hurme¹ and Jan Kramer²

¹Vita Laboratory, Helsinki, Finland; ²LADR MVZ Dr. Kramer und Kollegen, Geesthacht, Germany; ³Department of Forensic Medicine, Hjelt Institute, University of Helsinki, Finland; ⁴NBI Laboratory, Vantaa, Finland

Objectives: Phenazepam is a benzodiazepine that has been used as an anxiolytic, sedative-hypnotic and anti-epileptic mainly in Russia. It has, however, not been approved for prescription use in Finland and, unlike other benzodiazepines, it has not been scheduled as a narcotic. A typical therapeutic range in the treatment of anxiety is 0.020 – 0.060 mg/L. In Finland, as well as in some other countries, an increase in the illegal use of phenazepam has been observed in recent years. Phenazepam has also been detected as a co-finding in some confiscated batches of designer drugs like MDPV.

In this study, we examined the prevalence of phenazepam among drivers apprehended for driving under the influence of drugs (DUID) in Finland between July 1, 2010 and March 31, 2011. We also examined the prevalence of phenazepam in medico-legal autopsy cases in Finland during the same period. The number of seized phenazepam batches by the police in Finland is reported as well.

Materials and Methods: In this time period, blood samples from 3328 apprehended drivers were analyzed for the presence of phenazepam. An LC-MS/MS method preceded by solid phase extraction was used for the determination of phenazepam in DUID cases. In the post-mortem investigations, the sample preparation consisted of liquid-liquid extraction followed by derivatization. The determination of phenazepam was carried out by GCMS.

Results: There were 111 positive phenazepam cases among apprehended drivers, representing approximately 3.9% of all confirmed drug cases in the same time period. The median (range) phenazepam blood concentration in DUID cases was 0.058 mg/L (0.004 – 3.000 mg/L). Phenazepam was found in 14 medico-legal autopsy cases, and the median (range) blood concentration was 0.049 mg/L (0.007 – 1.600 mg/L). Phenazepam was not the sole cause of death in any of the cases.

There were 24 seizures of phenazepam by the Police. The batches consisted of fluids (6 times), tablets (9 times) and powder (9 times), and some of the samples were mixtures with e.g. buphedrone, methylone or MDPV.

Conclusion: Our data demonstrate increasing illegal use of phenazepam in Finland. The blood concentrations of phenazepam among apprehended drivers and autopsy cases are sometimes high. At least at high concentrations, phenazepam presumably causes psychomotor impairment. However, more data on the pharmacology and toxicology are needed in order to specify toxic and fatal concentrations. After long being a problem mainly in the Nordic countries, the aggressive internet marketing will presumably increase the prevalence of phenazepam also in other countries.

Key Words: Phenazepam, DUID, Postmortem Toxicology

Prevalence of Licit and Illicit Drugs in Whole Blood Among Danish Drivers in West Denmark**Mette Findal Andreassen***, Jørgen Hasselstrøm and Ingrid Rosendal

Section for Toxicology and Drug Analysis, Department of Forensic Medicine, Aarhus University, Aarhus, Denmark

Introduction: Driving under the influence of drugs (DUID) is a problem in Denmark as in most other countries. In 2007 fixed concentration limits in blood for drugs dangerous to road safety were introduced into the Danish traffic legislation. According to this law a driver is sanctioned if the blood concentration of a drug exceeds the limit (e.g. amphetamine > 0.02 mg/kg whole blood, tetrahydrocannabinol > 0.001 mg/kg whole blood and buprenorphine > 0.0005 mg/kg whole blood). The aim of the project was to document the prevalence and spectrum of common drugs amongst car drivers apprehended in West Denmark (Jutland) for drug-impaired driving.

Method: Whole blood samples from drivers suspected of DUID driving were collected by the police and a physician and sent to the Department of Forensic Medicine in Aarhus for toxicological analysis. The study covered three consecutive years (2008-2010). Whole blood samples were subjected to a broad screening analysis using immunological methods (until December 2009), UPLC-TOFMS (from December 2009 onwards) and LC-MS/MS. All positive results were quantified using LC-MS/MS and GC-MS.

Results: The data included 1557 blood samples from DUID offenders; 243, 602 and 712 samples from 2008, 2009 and 2010, respectively. On average 80 percent of the analysed samples (range: 76-82 %) were positive and above the fixed concentration limits for one or more drugs dangerous to road safety. In 51 % of the positive samples two or more drugs were detected with an average of two drugs per sample (max. seven drugs). Forty different drugs dangerous to road safety were detected, and in total 88 different drugs or metabolites were detected in the samples. Most of the suspects were men (94 %), with an average age of 29 years. Average age for women was 37 years. Tetrahydrocannabinol was the most prominent illicit drug seen in samples above the fixed concentration limits, ranging between 35-50 % of the samples. Benzodiazepines were found in 38-47 % of the samples, with clonazepam being the most frequent benzodiazepine found in 17-25 % of the samples. Amphetamine was found in 18-22 % of the samples and morphine in 8-9 % of the samples. After the introduction of the fixed limit law in July 2007 the number of DUID cases in Denmark has increased more than nine-fold from 237 cases in 2006 to 2141 cases in 2010. Approximately 1/3 were analysed at the laboratory in Aarhus in 2010.

Conclusion: Suspected DUID cases have increased dramatically after the introduction of fixed concentration limits into the Danish traffic legislation, and are currently ninefold higher than before the new legislation. On average 80 percent of the samples were above the fixed concentration limits; thus driving under the influence of drugs is a considerable problem in Denmark.

Keywords: DUID, Prevalence, Drugs, Denmark

Benzodiazepines, Zolpidem and Zopiclone Among Drivers Suspected to be under the Influence of Drugs

Nicolas Donze^{1*}, Maria Teresa Pinorini², Marc Augsburger³, Frank Sporkert³, Patrice Mangin³

¹Valais Hospital, Valais, Switzerland, ²IACT, Ticino, Switzerland, ³University Center of Legal Medicine, Lausanne-Geneva, Switzerland

Objectives: The aim of this study was to highlight the presence of benzodiazepines, Z-drugs (zolpidem and zopiclone) and/or alcohol in blood samples obtained from drivers suspected of driving under the influence of drugs (DUID).

Materials and Methods: Whole blood samples from drivers stopped by the police (road control, erratic driving or accident) in 2010 in four states of Switzerland (Vaud, Valais, Fribourg, Ticino) were analyzed in order to establish the presence of benzodiazepines, zolpidem, zopiclone (Z-drugs) and ethanol. LC-MS/MS (Shimadzu and AB Sciex 3200 Q trap) was used for the quantitative analysis of benzodiazepines and Z-drugs in whole blood. Ethanol blood concentration was determined by Head-Space-GC-FID.

Results: 832 cases were recorded: 742 men (89 %) and 90 women (11 %). The mean age was 31 ± 12 , (range: 15 - 89). 98 cases were positive for at least one benzodiazepine or Z-drug. In 12 samples the presence of midazolam (Dormicum[®]), a benzodiazepine currently used after a car crash for the induction of sedation and anesthesia before medical procedures was detected. The presence of benzodiazepines, zolpidem or zopiclone was detected in 86 cases (10 %): 63 men (8.5 % of all the men of this study) and 23 women (26 % of all the women of this study). The mean age was 44 ± 14 (range: 23- 89). Among these positive cases for benzodiazepines, 38 were positive for ethanol (≥ 0.10 g/kg) as well: 28 men (3.8%) and 10 women (11%). The mean age was 46 ± 13 (range: 23 - 76) and the median concentration for ethanol was 1.10 g/kg (range: 0.27 - 3.02 g/kg).

The principal benzodiazepines and Z-drugs detected were (N; median concentration; range): alprazolam (10; 29 $\mu\text{g/L}$; 4 - 117 $\mu\text{g/L}$), bromazepam (7; 430 $\mu\text{g/L}$; 12 - 2600 $\mu\text{g/L}$), clonazepam (2; 47 $\mu\text{g/L}$; 14 - 80 $\mu\text{g/L}$), diazepam (6; 44 $\mu\text{g/L}$; 6 - 740 $\mu\text{g/L}$), nordiazepam (30; 367 $\mu\text{g/L}$; 12 - 2425 $\mu\text{g/L}$), temazepam (2; 9 $\mu\text{g/L}$; 2 - 16 $\mu\text{g/L}$), oxazepam (36; 45 $\mu\text{g/L}$; 4 - 4300 $\mu\text{g/L}$), flunitrazepam (2; 19 $\mu\text{g/L}$; 10 - 29 $\mu\text{g/L}$), 7-amino-flunitrazepam (2; 54 $\mu\text{g/L}$; 28 - 79 $\mu\text{g/L}$), desalkyl-flurazepam (6; 59 $\mu\text{g/L}$; 28 - 1390 $\mu\text{g/L}$), lorazepam (22; 30 $\mu\text{g/L}$; 3 - 332 $\mu\text{g/L}$), midazolam (10; 70 $\mu\text{g/L}$; 6 - 133 $\mu\text{g/L}$), hydroxy-midazolam (9 ; 41 $\mu\text{g/L}$; 2 - 730 $\mu\text{g/L}$), phenazepam (2; 208 $\mu\text{g/L}$; 156 - 260 $\mu\text{g/L}$), zolpidem (8; 144 $\mu\text{g/L}$; 72 - 2200 $\mu\text{g/L}$), and zopiclone (6; 112 $\mu\text{g/L}$; 17 - 840 $\mu\text{g/L}$).

In 63 cases (73.3%) only one benzodiazepine or Z-drug was consumed. In 17 cases (19.8%) consumption of two benzodiazepines or Z-drugs has been shown. In 3 cases (3.5%) 3 substances were consumed. In 2 cases (2.3 %) 5 substances have been found and in one case the drivers consumed 6 substances (59 μg alprazolam/L, 332 μg lorazepam/L, 13 μg midazolam/L, 67 μg desalkyl-flurazepam/L, 335 μg nordiazepam/L, and 23 μg zopiclone/L).

Conclusion: The presence of benzodiazepines or Z-drugs was detected in 10% of the DUID samples collected in 2010. Women drivers were 3.0 times more likely to have consumed benzodiazepines or Z-drugs than men in the studied population. 44% of the drivers who had consumed benzodiazepines or Z-drugs had also consumed ethanol.

Key Words: Benzodiazepines, Z-Drugs, DUID, Switzerland

Driving Under the Influence of Hypnotics and Tranquilizers in the Region of Bern, Switzerland – Case Data and a Novel LC-MS/MS Method

Werner Bernhard*, Stefan König and Wolfgang Weinmann
Institute of Forensic Medicine, Bern, Switzerland

Introduction: Driving under the influence of hypnotics and tranquilizers is an increasingly serious problem. During the day, individuals may consume large amounts of coffee or other energizing drinks to stay alert and focused. In the evening, it becomes difficult for these subjects to fall asleep, and they may consume hypnotics or tranquilizers such as zolpidem, zopiclone, or benzodiazepines. Benzodiazepines are also widely used to treat other non-sleep related medical conditions. The prevalence of the newer z-drugs is compared to several benzodiazepines, and their impact on traffic safety is evaluated. Samples were collected during traffic controls and traffic accidents and analyzed in our laboratory by a newly developed screening and quantification method.

Methods: Routinely, benzodiazepines are screened by immunoassay (CEDIA) in urine with good selectivity and sensitivity. Two newer hypnotics and tranquilizers, zolpidem and zopiclone, are not included in this screen. Therefore, a LC-MS/MS method was developed to screen for zopiclone, zolpidem, and all benzodiazepines commercially available in Switzerland in a single method. The following benzodiazepines were included in the method (LOQ in parentheses) 7-NH₄-flunitrazepam, alprazolam, clonazepam, flunitrazepam, flurazepam, lormetazepam, norflunitrazepam, temazepam, triazolam, zolpidem, zopiclone (1.25 ng/mL) and bromazepam, desalkylflurazepam, diazepam, lorazepam, midazolam, nordiazepam, oxazepam (12.5 ng/mL). As internal standards: 7-NH₄-flunitrazepam-D₇, alprazolam-D₅, flunitrazepam-D₄, desmethylflunitrazepam-D₄, triazolam-D₄, desalkylflurazepam-D₄, diazepam-D₅, lorazepam-D₄, midazolam-D₄, nordiazepam-D₅, oxazepam-D₄, clonazepam-D₄, temazepam-D₅, zolpidem-D₆, zopiclone-D₄. Concentrations of internal standards were 0.5 µg/mL or 5.0 µg/mL. Precision, selectivity and specificity of the method was sufficient to meet GTFCH guidelines. 100 µL of human urine and 200 µL acetonitrile (containing internal standards) was aliquotted into deep 96-well plates. Plates were vortexed for 5 min and centrifuged for 35 min. Samples were then injected into the LC-MS/MS. A triple stage quadrupole mass spectrometer with linear ion trap capability (3200 QTrap, Analyst software [version 1.5.1], Applied Biosystems/MDS Sciex, Rotkreuz, Switzerland) was used in SRM scan mode (selective reaction monitoring) for mass spectrometric detection. Electrospray ionization with positive ion mode was used for all analytes. HPLC separation was performed on a Dionex high pressure system.

Results: Traffic accidents and controls for the last 6 months were reviewed. Among those positive for benzodiazepines or z-drugs, 10% had zolpidem or zopiclone at therapeutic levels. This indicated that z-drugs are taken as prescribed and drug abuse was not apparent. All benzodiazepines, zolpidem and zopiclone were analyzed within 3 min with appropriate sensitivity and selectivity. In order to achieve run times of 3 min, column switching with one trapping column and one analytical column was used. Column switching permitted shorter re-equilibration time and selectivity to reduce false positive results. Linearity was 1.25 to 125 ng/mL for 7-NH₄-flunitrazepam, alprazolam, clonazepam, flunitrazepam, flurazepam, lormetazepam, temazepam, norflunitrazepam, triazolam, and from 12.5 to 1250 ng/mL for bromazepam, desalkylflurazepam, diazepam, lorazepam, midazolam, nordiazepam, oxazepam with correlation factors ≥ 0.99 . A first order calibration ($y = a \cdot x + b$ and $1/x$ weighting factor) was applied. Precision and accuracy for the commercially available Medichem Drug control standard were $<11\%$ for all compounds and accuracy for all compounds were 85%-115%. Six different sources of human urine used for selectivity tests showed no major interferences.

Key Words: Traffic Safety, DUI, Benzodiazepines, Zolpidem, Zopiclone

Analysis of Cannabinoids in Total Blood Samples by Immunoassay Screening and UPLC-MSMS Confirmatory Analytical Method

Susana Sadler Simões, **Antonio Castañera***, Suzel Costa and Mário João Dias

National Institute of Legal Medicine-South Branch, Rua Manuel Bento de Sousa nº3, 1150-219 Lisbon, Portugal

Objective: Cannabis is the most popular illicit drug of abuse in the world. It is well known that the most abundant psychoactive substance present in cannabis, Δ^9 -tetrahydrocannabinol (THC), as well as its main metabolite 11-hydroxy-THC (11-OH-THC), both active substances, are present in blood samples in low concentrations hours after cannabis consumption while the concentrations of the non-psychoactive metabolite 11-nor-9-carboxy-THC (THCCOOH) are typically higher. Therefore, THCCOOH is frequently used as marker of cannabis abuse. However, in order to correctly interpret, not only the use of cannabis, but also to assess the state of influence, it is crucial to use analytical procedures with high selectivity and sensitivity to detect active substances, THC and 11-OH-THC. This work describes the strategy used in the Laboratory of Forensic Toxicology of the South Branch of the National Institute of Legal Medicine, for routine analysis of cannabinoids in whole blood samples using an ELISA (BIO-RAD – Orasure Technologies) as the screening method and an ultra performance liquid chromatography triple quadrupole mass detector (UPLC-MSMS) as the confirmatory method.

Materials and Methods: Samples for confirmation were prepared by solid-phase extraction and analysed by UPLC-MSMS using positive electrospray ionization and multiple reaction monitoring. Chromatographic separation was performed with an Acquity UPLC® HSS T3 (50 x 2.1 mm i.d., 1.8 μ m) with a total run time of 9.5 min.

Results: The confirmatory method (UPLC-MSMS) was validated in terms of selectivity, capability of identification, limits of detection (0.2 μ g/L for THC and 0.5 μ g/L for 11-OH-THC and THCCOOH) and quantitation (0.5 μ g/L for all cannabinoids), recovery (53-115%), carryover, matrix effect (34-43%), linearity (0.5-100 μ g/L), intra-assay precision (CV<10%), inter-assay accuracy and precision (CV<11%). Capability of detection and sensitivity were validated for the screening (immunoassay) method. The method was used in analysis of 23 whole blood samples of injured and fatal victims of road traffic accidents and allowed the detection of THCCOOH in all 23 samples with a mean value of 25 ng/mL (range 3.9-107 ng/mL), THC in 19 samples with a mean value of 2.8 ng/mL (range 0.6-8.2 ng/mL) and 11-OH-THC in 15 samples with mean value of 1.4 ng/mL (range 0.6-3.0 ng/mL).

Conclusion: The results obtained show that the described methodologies allow the detection of cannabis positive samples and confirmation of THC, 11-OH-THC and THCCOOH.

Key Words: Cannabinoids, UPLC-MSMS, Blood

3,4-Methylenedioxyamphetamine (MDMA) and Metabolites in Oral Fluid Collected with the Intercept® Device and by Expectoration Following Controlled Oral MDMA Administration

Karl B. Scheidweiler*¹, Allan J. Barnes¹, Tsadik T. Abraham^{1,2}, Erin A. Kolbrich Spargo^{1,3}, David A. Gorelick¹, Robert S. Goodwin¹ and Marilyn A. Huestis¹

¹Chemistry and Drug Metabolism, NIDA-IRP, NIH, Baltimore, MD, USA; ² Office of the Chief Medical Examiner, Baltimore, MD, USA; ³Southwestern Institute of Forensic Sciences, Dallas, TX, USA

Objectives: Oral fluid (OF) is collected non-invasively under direct observation, creating interest in this alternative matrix for driving under the influence of drugs, workplace, pain management, and drug treatment testing. We present distribution of 3,4-methylenedioxyamphetamine (MDMA) and its primary metabolite 3,4-methylenedioxyamphetamine (MDA) into OF collected concurrently via expectoration and Intercept® collection device (Orasure Technologies, Inc) following controlled oral MDMA administration.

Methods: 16 males and 10 females with a history of MDMA use provided written informed consent for this IRB-approved study. Participants were administered placebo, 1.0, and 1.6 mg/kg MDMA double-blind in random order in separate sessions while residing on a closed research unit. MDMA and MDA disposition in oral fluid collected with Intercept device or via expectoration was assessed 0.3-143 h after MDMA administration. Intercept specimens were collected 2-15 min after expectoration. OF concentrations were determined by GCMS with 5 and 15 ng/mL limits of quantification in expectorated and Intercept, respectively, for both analytes. C_{max} and T_{last} were calculated for 8 participants who completed all dosing sessions and provided OF specimens over 143 h. Correlations between concentrations for both collections were evaluated with Spearman's rho. C_{max} and last detection times (T_{last}) computed with 20, 25 and 50 ng/mL cutoffs for each collection technique were compared with Wilcoxon signed-rank test ($p < 0.05$). Analyte expectoration:Intercept ratios were evaluated via Kruskal-Wallis test with follow-up Wilcoxon tests ($p < 0.05$).

Results: MDMA and MDA C_{max} were equivalent in expectorated and Intercept OF specimens ($p > 0.05$). Expectorated C_{max} were 1160-3382 and 2881-11986 ng/mL for MDMA, 23.1-151 and 50.5-403 ng/mL for MDA after low and high doses, respectively. Intercept C_{max} were 1337-2865 (low) and 1883-6312 (high) ng/mL for MDMA, 24.5-106 (low) and 48.2-221 (high) ng/mL for MDA. 78 and 81.3% of specimens collected for up to 143 h after 1.0 or 1.6 mg/kg oral MDMA exceeded 15 ng/mL MDMA in expectorated and Intercept OF; 47% of all specimens exceeded 15 ng/mL MDA. Paired positive expectorated and Intercept OF specimens were significantly correlated ($r = 0.87$, $n = 787$, $p < 0.001$) and ($r = 0.72$, $n = 446$, $p < 0.001$) for MDMA and MDA, respectively. Expectorated:Intercept MDMA OF ratios significantly varied across time after low and high doses ($p < 0.05$) and MDA ratios significantly varied after high dose ($p < 0.05$); although there were not any consistent patterns of significant differences between collection device MDMA and MDA OF concentrations. MDMA and MDA guidelines for research on drugged driving from the September 2006 meeting in Talloires, France, the European initiative Driving Under the Influence of Drugs, Alcohol and Medicines (DRUID) and the US Substance Abuse and Mental Health Services Administration (SAMHSA) propose 20, 25 and 50 ng/mL OF cutoff concentrations, respectively. Expectorated MDMA T_{last} were 23-34, 23-34 and 13-19 h after low dose; 29-47, 29-47 and 23-47 h after high dose MDMA for Talloires, DRUID and SAMHSA cutoffs, respectively. MDMA T_{last} were 23-47, 15-34 and 15-29 h (low); 34-47, 29-47 and 23-47 h (high) for Intercept-collected OF with Talloires, DRUID and SAMHSA cutoffs, respectively.

Conclusions: Similar duration of detection and detection rates for MDMA and MDA in OF were observed for expectorated or Intercept-collected OF following oral MDMA administration. MDMA and MDA expectoration:Intercept ratios varied significantly, although there were no consistent patterns of significant differences between collection techniques. (Supported by the National Institutes of Health, Intramural Research Program, National Institute on Drug Abuse)

Key Words: MDMA, Oral Fluid, Expectoration, Intercept

Driving Under the Influence of Drugs: The England and Wales Perspective

Jennifer Button*, Michael Scott-Ham, and Andrew Clatworthy
DDU Teams Forensic Science Service, London & Chorley, UK

Objectives: Driving under the influence of drugs (DUID) is a growing concern in developed countries. Driving ability may be impaired by the use of psychoactive substances, leading to an increased risk of fatal and non-fatal road traffic collisions (RTC). The Forensic Science Service (FSS) is the largest provider of DUID analysis in England and Wales. This paper presents the retrospective analysis of toxicological investigations undertaken by the FSS on apprehended drivers suspected to have been under the influence of drugs.

Method: For a 12-month period (December 2009 to November 2010) a total of 1531 specimens (1389 blood, 142 urine), obtained from apprehended drivers, were submitted by police forces (36) across England and Wales to the FSS for the analysis of illicit drugs. Of these, 50 were collected following fatal RTC. Specimens were primarily obtained from males (88%). Samples were initially screened for a range of common drugs of abuse by immunoassay (Cozart, Abington, UK). Drugs/drug classes tested included amphetamines, methylamphetamines (including MDMA), opiates, benzodiazepines (diazepam, temazepam), methadone, cocaine metabolite and cannabinoids. Results were assessed against in-house assay cut-off concentrations and assigned a positive or negative outcome. All positive immunoassay results are presented here. GC-MS was used for targeted analysis for a named drug or for screening a range of drugs (e.g. chemically basic drugs such as ketamine and methylmethcathinones). Broader testing was conducted if another relevant drug was implicated in the case circumstances or if an initial immunoassay screen was negative and the customer authorised further testing. Of the results obtained normally only one, that most applicable to the case circumstances and/or likely to produce impairment of driving, would be quantified and/or confirmed, by GCMS, according to police submission policies.

Results: One or more drugs were detected in 80% of cases (blood or urine). Cannabis was the most frequently encountered drug and was detected in 46% of cases. This was followed by benzodiazepines (36%), opiates (30%), cocaine (22%), amphetamine (12%), methadone (10%) and methylamphetamine (4%). Polydrug use was prevalent, with more than one drug being detected in 42% of cases. The average number of drug groups detected per sample was 2. The most frequently combined drug groups were opiates and benzodiazepines (4%) followed by cannabis and benzodiazepines (3.5%). Mephedrone, one of the new “legal highs” that were recently controlled in the UK, was detected in 65 cases following either its implication in the case history or detection during other confirmatory analysis.

Conclusion: The data showed that many drivers abusing drugs are poly-drug users. As expected, cannabis was the most frequently encountered drug. Other depressant drugs were also frequently encountered. Stimulant drugs were detected in fewer cases. Mephedrone was detected in a number of cases even though it would not be detected in a routine case due to unavailability of a commercial immunoassay screening test.

Key Words: DUID, England, Wales

Do DUI Enforcement Procedures Miss Drugs When Alcohol is Present in Driving Under the Influence Cases?Charlotta Engblom, Tom Blencowe, Kaarina Langel and **Pirjo Lillsunde***

Institute for Health and Welfare, Mannerheimintie 166, FI-00300 Helsinki Finland

Introduction and Objectives: In Finland, the police are authorized by law to submit drivers to on-site breath alcohol screening tests. When drug use is suspected, external drug use symptoms are documented and on-site oral fluid devices can be used. An evidential breath-alcohol test is conducted or a blood sample is taken if the breath screening test is positive for alcohol. If the police officer suspects drug use, a blood sample is taken. The police can request one of three options: only blood alcohol concentration (BAC) is analysed, only drugs of abuse or medicinal drugs are analysed or both alcohol and drugs are analysed.

Material and methods: All driving under the influence (DUI) specimens (N=475) that were sent to the laboratory between April 5-18, 2008 were included in this study. BAC was analysed by head-space gas chromatography flame ionization detection (GC-FID) and drugs by GC-mass spectrometry (MS). The substance classes analyzed included drugs harmful for traffic safety such as amphetamines/stimulants, cannabinoids, opioids, benzodiazepines, other hypnotics/sedatives, antidepressants and analgesics.

Results: Of the 475 blood samples arriving in the laboratory during the study weeks, 301 requested alcohol analysis only, 130 drugs only and 44 alcohol and drugs. Only 7 samples were negative for all substances. In addition to alcohol (N=300), benzodiazepines (N=146), amphetamines (N=112) and cannabinoids (N=49) were the most common findings. 22% of all suspected DUI drivers were positive for only one group of drugs, 17% for two groups of drugs and 6% for three or more groups of drugs. 31% of the drivers were benzodiazepine positive (N=146) and poly-drug use was common with benzodiazepines. The mean positive alcohol result was 1.91‰ when only alcohol analysis was requested, below the legal limit (0.5 ‰) when only drugs were requested and 1.30‰ when both alcohol and drugs was requested.

When 'only alcohol' analysis was requested (N=301), alcohol was positive in all cases, except one. In addition, drugs were found in 22% of cases suspected for alcohol only (N=66), these were mainly benzodiazepines. The predominant findings were diazepam and nordiazepam (10%) at concentrations of 0.1-1.8 mg/L. In several cases, temazepam (0.1-1.4 mg/L), alprazolam (0.02-0.48 mg/L), chlordiazepoxide (0.2-4.0 mg/L), clonazepam (0.01-0.12 mg/L) and oxazepam (0.1-0.6 mg/L) were detected. Two amphetamine cases (0.03 mg/L and 0.15 mg/L) were found in the 'alcohol only' group. Of the cannabinoids, only the inactive metabolite THCCOOH (N=10) was found when 'alcohol only' analysis was requested.

Conclusions: The study shows that opting only for alcohol analysis as a result of the alcohol breath test seldom led to illicit drugs being missed in the Finnish DUI enforcement procedure. The excellent detection of illicit drugs use was achieved by training the police officers to recognise external symptoms of drug use and by providing them with on-site oral fluid collection devices. Benzodiazepines were a more challenging group to recognise at the roadside when alcohol was present.

Key Words: Driving Under the Influence, Drugs, Enforcement

2-Amino-5-Chloropyridine – A Potential Marker for Zopiclone Degradation in Forensic Cases

Gunnel H. Nilsson*^{1,2}, Fredrik C. Kugelberg^{1,2}, Johan Ahlner^{1,2} and Robert Kronstrand^{1,2}

¹Department of Forensic Genetics and Forensic Toxicology, National Board of Forensic Medicine, Linköping, Sweden;

²Department of Medical and Health Sciences, Linköping University, Linköping, Sweden

Objectives: Zopiclone is a short-acting hypnotic drug and a commonly abused substance often detected in blood samples from drug-impaired drivers, recreational drug users and forensic autopsy cases. Zopiclone is a notoriously unstable analyte in biological matrices and analytical results depend on pre-analytical factors, such as storage time and conditions. A potential degradation product from zopiclone is 2-amino-5-chloropyridine (ACP). The aims of this study were to closely investigate zopiclone degradation in spiked and authentic human whole blood in the pre-analytical phase as well as during various storage conditions and to identify and quantify potential markers or degradation products that still may be present when zopiclone has broken down.

Materials and Methods: In a controlled study, whole blood from nine volunteers was obtained before and after oral administration of 10 mg Imovane[®]. Portions of pre-dose spiked blood (target concentration 0.08 µg/g) and post-dose samples were after initial measuring, stored at 20°C for 5 days, 5 or –20°C for 3 months and zopiclone stability was evaluated. In a degradation experiment, spiked blood samples to 0.3 µg/g were stored at 37°C for 24 hours and the formation of ACP was investigated. From forensic cases, authentic samples were stored at 5°C during one month and zopiclone degradation and ACP formation were studied. All blood samples contained sodium fluoride and potassium oxalate as preservatives. After liquid/liquid-extraction zopiclone was quantified by GC-NPD and ACP was determined by LC-MS/MS.

Results and Conclusions: The results from the controlled study showed that zopiclone was stable for less than one day at 20°C and less than two weeks at 5°C. Both post-dose authentic samples and pre-dose spiked blood samples showed the same degradation trend. In the degradation study ACP was identified as a major product from zopiclone in stored blood samples and an equimolar degradation was observed. In the authentic forensic case samples, the mean value of zopiclone decrease was 21% and the mean value of ACP increase was 23% after one-month storage, supporting the findings from the controlled study. However, there was a great variation in degradation of zopiclone and formation of ACP between the authentic cases and this can be explained by the presence of the metabolites N-desmethylzopiclone and zopiclone N-oxide that also might degrade to ACP.

Interpretation of zopiclone concentrations in whole blood in forensic toxicology is not easy owing to its instability in blood samples. The rapid degradation at ambient temperature can cause an underestimation of the true concentration and consequently flaw the interpretation. Depending on the conditions in the pre-analytical phase zopiclone may not be detected at all. Since ACP was identified in all authentic cases, the measurement of ACP might be a potential marker for zopiclone intake in forensic cases even when zopiclone has disappeared completely.

Key Words: Zopiclone, Degradation, 2-Amino-5-Chloropyridine

Comparison of Illicit Drug Consumption in 1999 and 2009 in Individuals Suspected of Unfitness to Drive Due to Abusive Consumption of Drugs

Marc Augsburger*, Vincent Varlet, Frank Sporkert, Patrice Mangin, and Bernard Favrat
University Centre of Legal Medicine, Lausanne-Geneva, Switzerland

Objectives: A three week testing procedure was developed in canton de Vaud (Switzerland) to evaluate the abusive consumption of drugs in a portion of the driving population. This procedure was used to assess driving ability among drivers obtaining a driver's license or those involved in license revocation proceedings. If drugs were not detected in three urine samples (obtained weekly over the three week period), drug addiction was not suspected. If the results showed that the drivers were not able to refrain from consuming drugs during the three week period, a full evaluation of the individual's ability to drive was conducted. The aim of the study was to compare results obtained during the first year after introduction of the procedure (1999) and the results obtained ten years later (2009).

Methods: Urine samples were screened by immunoassay for amphetamines (cut-off: 500 ng/mL equivalent d-amphetamine), benzodiazepines (cut-off: 100 ng/mL equivalent lormetazepam), cocaine (cut-off: 300 ng/mL equivalent benzoylecgonine), cannabinoids (cut-off: 50 ng/mL equivalent 11-nor-9-Carboxy-THC), opiates (cut-off: 300 ng/mL equivalent morphine) and methadone (300 ng/mL equivalent methadone). Urine creatinine concentrations were also determined. Confirmation and quantitative analysis were performed by validated GC-MS methods.

Results: In 1999, 93 urine samples were analyzed from 26 men (84%) and 5 women (16%). The mean age was 30 ± 9 yrs (range: 20-58 yrs). No substances were observed in the urine samples from 12 drivers (39%). At least one urine sample (of the three collected) was positive for at least one substance from 19 drivers (61%). 15 drivers (79%) had positive urines each of the three weeks for at least one substance. Among the 19 drivers positive for one substance, 13 (68%) were positive for methadone, 11 (58%) for cannabinoids, 5 (26%) for benzodiazepines, 4 (21%) for opiates, 2 (11%) for cocaine and 1 (5%) for amphetamines.

In 2009, 939 urine samples were analyzed from 284 men (91%) and 29 women (9%). The mean age was 30 ± 9 yrs (range: 16-65 yrs). No substances were observed in the urine samples from 202 drivers (65%). At least one urine sample (of the three collected) was positive for at least one substance from 111 drivers (35%). 66 drivers (59%) had positive urines each of the three weeks for at least one substance. Among the 111 drivers positive for one substance, 71 (64%) were positive for cannabinoids, 22 (20%) for methadone, 22 (20%) for benzodiazepines, 19 (17%) for cocaine and 18 (16%) for opiates. Amphetamines were not detected in any urine samples.

Conclusions: Ten years after the development of a procedure to evaluate the abusive consumption of drugs among drivers, the number of drivers tested increased by a factor ten. In 1999, the majority of drivers were positive for methadone because the procedure was launched in particular for people following substance abuse therapy programs. Ten years later, prosecuted DUI drivers were also included into the procedure some weeks after their offence. This inclusion may explain the lack of drugs in the majority of samples in 2009.

Keywords: DUID, Drugs, Addiction

Proof of Concept for Automated SPE/HPLC/MS/MS Methods to Replace Traditional Immunoassay with MS Confirmation of Driving Under the Influence Samples

Robert M. Sears¹, and Kenneth Lewis²

¹South Carolina Law Enforcement Division, PO Box 21398, Columbia, SC 29221-1398, USA; ²OpAns, LLC, 4134 South Alston Ave, Suite 101, Durham, NC 27713, USA

Introduction and Objectives: Today, many forensic labs face difficulties related to budget cuts, reduced staffing, the need to effectively utilize instrument time and resources, and a need to increase the productivity of the remaining scientists. We hope to introduce a relatively new automated sample preparation system known as Instrument Top Sample Preparation (ITSP) coupled to liquid chromatography/mass spectrometry/mass spectrometry (LC/MS/MS) as a possible solution to improve productivity within the Forensic Toxicology laboratory. The ITSP system provides integrated online sample preparation which is controlled via the mass spectrometer software and utilizes disposable extraction cartridges. Comparison of data generated with ITSP/LC/MS/MS and data generated in a Forensic Toxicology laboratory using standard solid phase extraction (SPE) and gas chromatography/mass spectrometry (GC/MS) or LC/MS/MS analysis will be provided. This presentation will compare results obtained from both methods of confirmation of urine samples submitted in Driving Under the Influence (DUI) cases from South Carolina. All results provided in this study are from actual case samples.

Materials and Methods: Upon initial receipt, samples were screened for amphetamine/methamphetamine, benzodiazepines, cocaine metabolite (benzoylecgonine), opiates, and THC metabolite (THCA) using Abbott Diagnostics fluorescence polarization immunoassay (FPIA). Previously validated confirmation methods using GC/MS or LC/MS/MS were utilized on samples which were positive on screening for one or more of the previously listed drug classes or had a history of drugs suspected, provided by the submitting agency, which fell outside of the normal five panel immunoassay screening. Aliquots of confirmed positive samples were supplied to OpAns for testing utilizing the ITSP system. Confirmed positives covered all classes of drugs listed previously and accounted for over fifty different analytes of interest.

Discussion: OpAns has configured an Agilent 1260 HPLC, CTC PAL autosampler and Agilent 6430 triple quadrupole mass spectrometer into an automated platform for SPE/LC/MS/MS using the ITSP system. This system was originally designed to perform clinical diagnostic assays in support of pain management physicians. The samples provided by the crime laboratory were analyzed using two assays: one assay for THCA and barbiturates, the other assay for the remaining compounds of interest (>50 analytes). With the exception of glucuronide cleavage, each assay is fully automated and is performed in less than 10 minutes.

The presentation will contain detailed descriptions of the systems employed, figures of merit for the analytical methods, a comparison of results from >100 actual case samples and a comparison of time and cost savings related to deployment of SPE/LC/MS/MS based on ITSP into the forensic laboratory.

Key Words: Drugs of Abuse, Automation, HPLC/MS/MS, ITSP

Relationship Between Drug Use and Travel Length Among Brazilian Truck Drivers

Daniele Mayumi Sinagawa^{*1}, Heráclito Barbosa de Carvalho¹, Gabriel Andreuccetti¹, Wagner Schmitz², Keziah Cristina Barbosa Gruber de Oliveira², Mauricio Yonamine³, Daniel Romero Muñoz¹ and Vilma Leyton¹

¹Faculty of Medicine, University of Sao Paulo, Brazil; ²Department of Federal Highway Police, Brazil; ³Faculty of Pharmaceutical Sciences, University of Sao Paulo, Brazil

Introduction: Freight transportation in Brazil is predominantly carried out on the 1.7 million km of highways by approximately 1.4 million trucks. The truck drivers frequently travel long distances and must accomplish their task in a short period of time, which may force them to use substances to control sleepiness and anxiety associated with their job. According to previous studies conducted in Brazil, truck drivers reported using drugs of abuse such as cocaine and marijuana and controlled medicines, such as anorectics, which contain amphetamine analogues, mainly fenproporex and diethylpropion. Therefore, drug use by these professionals represents an important risk factor for highway accidents.

Objective: The purpose of this study was to test the hypothesis that drug use (amphetamines, cocaine and cannabinoids) by Brazilian truck drivers was associated with the length of their travel.

Methods: Truck drivers were randomly stopped by police officers on interstate roads during morning hours in 2009. No specific day of the week was selected and participation in the study was anonymous and voluntary. After signing a consent form, drivers were invited to provide urine samples for analysis. Additionally, they answered a simple questionnaire concerning their current travel, recent drug use and health problems. Urine drug screening tests (amphetamine, cocaine metabolites and cannabinoids) were performed using immunoassays (On-Site CupKit 501, Varian). Positive screening results were confirmed by previously published methods using gas chromatography–mass spectrometry (GC–MS). The following cut-off values were used in the confirmation test: amphetamine/methamphetamine=500 ng/mL, delta-9-tetrahydrocannabinol-9-carboxylic acid=15 ng/mL and benzoylecgonine=150 ng/mL. The travel length was classified as: short (≤ 100 km), medium (>100 and <500 km) and long distance (>500 km).

Results: Seven hundred truck drivers were stopped and only 35 refused to participate in the study. Of those who accepted and provided a urine specimen (n=665), 11% (n=71) were positive for the presence of at least one of the tested drugs: 7.1% (n=47) for amphetamine, 2.6% (n=17) for benzoylecgonine and 1.5% (n=10) for cannabinoids. None of the truck drivers who reported a short distance travel had a positive amphetamine result. On the other hand, those who reported medium and long distances had a higher prevalence of amphetamine use (4.6% and 13.3%, respectively; $p < 0.01$). However, no significant association was found between travel length and any of the other drugs.

Conclusion: A high prevalence of drug use, especially amphetamines, was found among truck drivers who reported medium and long distances travels. These results indicate that the current work conditions among truck drivers, particularly the journey length, and the availability of illicit drugs are of great concern regarding traffic safety in Brazil (LIM-40-HCFMUSP/DPRF).

Key Words: Truck Drivers, Drugs, Brazil

Methadone and Driving in the City and County of San Francisco

Cecilia O. Medina^{*1}, Justin A. Volk¹, Jonas E. Knight¹, Eric A. Ingle¹, Chinyere M. Williams¹, Pavlos Karamanidis¹, Glenda M. Easterling¹, Ann M. Gordon¹ and Nikolas P. Lemos^{1,2}

¹Office of the Chief Medical Examiner, 850 Bryant Street, San Francisco, CA, 94103 USA; ²Department of Laboratory Medicine, School of Medicine, The University of California, San Francisco, CA 94143, USA

Objectives: To present the incidence and blood concentrations of methadone in drivers arrested in the City and County of San Francisco for allegedly driving while impaired during a 12-month period.

Methods: San Francisco has approximately 815,000 residents within a greater metropolitan area of about 7.15 million, 50.8% Male and 49.2% Female. The city is racially diverse with 58.0% White, 31.4% Asian, 14.4% Hispanic/Latino and 6.7% Black. California law states that it is unlawful for any person who is under the influence of any alcoholic beverage or drug, or under the combined influence of any alcoholic beverage and drug, to drive a vehicle. The Forensic Laboratory Division of the Office of the Chief Medical Examiner prepares and distributes evidence kits, containing 3 grey-top tubes and sterile phlebotomy supplies, for the collection of blood in suspected DUI cases. These tubes contain anticoagulant (potassium oxalate) and preservative (sodium fluoride). After ethyl alcohol testing, if requested by the arresting officer, the blood was screened for drugs using an enzyme-linked immunosorbent assay (ELISA) by Venture Labs Inc. The ELISA cut-off for blood methadone is 20 ng/mL. Methadone confirmation and quantitation are performed by gas chromatography–mass spectrometry with a limit of quantitation of 0.1 mg/L with tripeleminamine as an internal standard. The m/z ions monitored for tripeleminamine are 91, 58, 197 and for methadone 72, 115, 294. Results are reviewed and entered into the in-house computerized database for dissemination to law enforcement officers. The database was queried for driving cases from 1 July 2009 to 30 June 2010 positive for methadone. The case files were manually reviewed and results for methadone tabulated using commercially available spreadsheet software.

Results: In the 12-month period, the Division analyzed 928 driving cases and reported methadone in 8. There were 5 males (63%) and 3 females (27%), aged 28 to 63 years (mean: 43 years; median: 44 years). Males' age ranged from 28 years to 63 years and females' from 29 to 52. Mean methadone concentration was 0.22 mg/L (median: 0.19) with a range from 0.11 to 0.40 mg/L. In male drivers, blood methadone averaged 0.22 mg/L (median: 0.21 mg/L) and in females, 0.20 mg/L (median 0.16). Methadone was never found alone in the blood specimens, but was combined with benzodiazepines, cannabis, morphine, codeine, cocaine, hydrocodone, phencyclidine, methamphetamine and amphetamine.

Discussion and Conclusions: In the vast majority of driving cases submitted to the Division, the measured blood alcohol concentrations were high enough to eliminate the need for comprehensive drug testing. Consequently, the relatively low incidence of methadone positive driving cases is likely artificially low at 0.9 per 100,000 based on a population of 815,000. Polypharmacy appears to be the norm in these drivers as methadone was always found in combination with one or more psychoactive drugs. Mean and median blood methadone concentrations were similar to those who died of natural causes (as reported elsewhere), which further suggests that interpretation of methadone toxicology results in isolation should be avoided as it could lead to incorrect inferences.

Key Words: Methadone, Driving Under the Influence, San Francisco

Felony Driving Under the Influence of Alcohol Cases Over a Four-Year Period in San Francisco

Jonas E. Knight^{*1}, Justin A. Volk¹, Eric A. Ingle¹, Chinyere M. Williams¹, Pavlos Karamanidis¹, Glenda M. Easterling¹, Cecilia O. Medina¹, Ann M. Gordon¹ and Nikolas P. Lemos^{1,2}

¹Office of the Chief Medical Examiner, City and County of San Francisco, 850 Bryant Street, San Francisco, CA 94103, USA; ²Department of Laboratory Medicine, School of Medicine, The University of California, San Francisco, CA 94143, USA

Objectives: California is a *per se* State for alcohol DUIs, as it is unlawful for “any person who has 0.08% or more, by weight, of alcohol in their blood to drive a vehicle.” Additionally, a DUI is elevated to felony if: (1) another person suffers injury or death because the driver (a) drove under the influence, *and* (b) either committed an *additional* vehicle code violation or drove in an otherwise negligent manner; (2) the driver has *three or more* prior DUI convictions *within the last ten-years*; or (3) the driver has a previous felony conviction. Forensic alcohol results from all alleged felony DUI cases from the Forensic Laboratory Division of the Office of the Chief Medical Examiner of the City & County of San Francisco from 01/01/2007 to 31/12/2010 are presented.

Methods: The Division prepares and distributes evidence kits for the collection of blood evidence in suspected DUI cases. Potassium oxalate is the anticoagulant and sodium fluoride is the preservative. Blood is analyzed in duplicate isothermally (40°C) for ethanol and related volatiles using n-propanol as internal standard by headspace gas chromatography with flame ionization detection (Agilent Technologies, Santa Clara, CA) with two different chromatographic columns (DB-ALC1 and DB-ALC2). All alleged felony DUI cases over the 4-year period were retrospectively reviewed.

Results: 456 alleged felony DUI cases were submitted between 2007 and 2010, but 18 (4%) were not tested due to chain of custody or other administrative issue. There were 170, 93, 91, and 102 cases analyzed in 2007, 2008, 2009 and 2010, respectively, with 92 female (20%) and 353 male (77%) drivers. The sex of 11 drivers (3%) was not indicated. The age of the drivers ranged from 14 to 77 years (mean: 33.6; median: 31.0). Ethanol (alone or in combination with other substances) was detected in 70% of all felony DUI-ALC cases. BAC ranged from 0.00 to 0.35% (w/v) with a mean and median of 0.11 and 0.13% (w/v), respectively. Mean and median female BAC were 0.13 and 0.14% (w/v), respectively; males BAC were 0.11% and 0.12% (w/v), respectively. 72% of female and 63% of male BAC results were $\geq 0.05\%$ (w/v). BAC of 0.08% (w/v) or greater was found in 68% of female and 61% of male drivers. BAC greater than 0.20% (w/v) in women was predominantly encountered in younger age groups (none in females younger than 21 years, 42% in females 21-30 years old and 29% in females 31-40 years old) with lower incidence in older female drivers (21% in females 41-50 years old and 13% in females older than 50 years). Males manifested a different age distribution for BAC greater than 0.20% (w/v) (3% in males younger than 21, 30% in males 21-30 years old, 30% in males 31-40 years old, 19% in males 41-50 years old and 17% in males older than 50 years).

Conclusions: Our study suggests that even though many fewer females are arrested for alleged misdemeanor DUI offences, and despite San Francisco having fewer females than male residents (49% vs. 51%), females have on average higher BAC than men. Mean BACs for female and male drivers were 0.13 and 0.11% (w/v), respectively, which are substantially higher than the *per se* limit in California. This suggests that the campaigns against drinking and driving may not be effective in tackling this significant health and safety issue. Additionally, it appears from our data that law enforcement agents are not intercepting drivers with lower but still impairing levels of alcohol, due to many reasons including inadequate resources and insufficient training.

Key Words: Felony DUI, Forensic Alcohol Analysis, City and County of San Francisco

Misdemeanor Driving Under the Influence of Alcohol Cases Over a Four-Year Period in San Francisco

Justin A. Volk^{*,1}, Jonas E. Knight¹, Eric A. Ingle¹, Chinyere M. Williams¹, Pavlos Karamanidis¹, Glenda M. Easterling¹, Cecilia O. Medina¹, Ann M. Gordon¹ and Nikolas P. Lemos^{1,2}

¹Office of the Chief Medical Examiner, City and County of San Francisco, 850 Bryant Street, San Francisco, CA 94103, USA; ²Department of Laboratory Medicine, School of Medicine, The University of California, San Francisco, CA 94143, USA

Objectives: The law renders California a *per se* State for alcohol DUIs by stating, among other provisions that “it is unlawful for any person who has 0.08 percent or more, by weight, of alcohol in blood to drive a vehicle.” This study reviews the forensic alcohol results for all alleged misdemeanor driving under the influence of alcohol offenses handled by the Forensic Laboratory Division of the Office of the Chief Medical Examiner of the City & County of San Francisco between 2007 and 2010.

Methods: The Division prepares and distributes evidence kits for blood collection in suspected DUI cases. Potassium oxalate is the anticoagulant and sodium fluoride the preservative. Blood is analyzed isothermally (40°C) in duplicate for ethanol and related volatiles using n-propanol as internal standard by headspace gas chromatography with flame ionization detection (Agilent Technologies, Santa Clara, CA) using two different chromatographic columns (DB-ALC1 and DB-ALC2). All alleged misdemeanor DUI cases from 2007-2010 were retroactively reviewed.

Results: 2766 misdemeanor DUI cases were submitted to the Division over the 4 years. 60 cases (2%) were not tested due to chain of custody or other administrative issues. There were 502, 605, 789, and 870 cases analyzed in 2007, 2008, 2009 and 2010, respectively, with 2178 males (79%) and 478 females (17%). The gender of 110 drivers (4%) was not specified. The drivers' age ranged from 15 to 85 years (mean: 34; median: 31). Ethanol (either alone or in combination with other substances) was detected at or greater than 0.01% (w/v) in 91% of all cases. BAC ranged from 0.00% to 0.42% with a mean and median of 0.15 and 0.21%, respectively. 91% of females and 89% of males had a BAC \geq 0.05% and in 85% of females and 83% of males the BAC \geq 0.08%. Female drivers had mean and median BAC of 0.21%, while males had mean and median BAC of 0.15%. BAC \geq 0.20% in females was encountered in a Gaussian distribution with only 2% younger than 21 years, 24% 21-30 years old, 28% 31-40 years old, 25% 41-50 years old and 10% older than 50 years. Males exhibited a skewed distribution regarding BAC \geq 0.20% (w/v): 1% younger than 21, 33% 21-30 years old, 29% 31-40 years old, 23% 41-50 years old and 16% older than 50 years.

Conclusions: Although many fewer females are arrested for alleged misdemeanor DUI offences, and (2) San Francisco has fewer females than male residents (49% versus 51%), females have on average higher BAC than men. The mean female BAC of 0.21% is substantially higher than the last reported female BAC from 2002-2006 of 0.17%. Males showed a slight decrease in mean BAC (0.15%) compared to the mean BAC from 2002-2006 (0.16%). Based on the average BAC of drivers intercepted by police, law enforcement agents operating in this jurisdiction may not be adequately resourced or trained to recognize drivers with lower but still impairing levels of alcohol. Finally, it also appears that the ‘Don't Drink and Drive’ campaigns are not reaching female drivers in San Francisco to the same degree they reach male drivers, suggesting that stronger efforts are needed to educate females on the dangers of drunk driving.

Key Words: Misdemeanor DUI, Forensic Alcohol Analysis, City and County of San Francisco

Evaluation of Alcohol and Psychoactive Substances in Blood Samples of Drivers Involved in Traffic Accidents

Fatih Acar^{1*}, İsmail Ateş¹, Yeter Erol¹, Esra Küçükibrahimoğlu¹, Ayşegül Şahin¹, Rezzan Gülhan^{1,2} and Mahmut Aşirdizer^{1,3}
¹Council of Forensic Medicine, Istanbul Chemistry Department Narcotic Division, Istanbul, Turkey; ²Marmara University School of Medicine, Department of Pharmacology, Istanbul, Turkey; ³Celal Bayar University, Department of Forensic Medicine, Manisa, Turkey

Objectives: Traffic accidents resulting from driving under the influence of drugs (DUID) are a serious problem throughout the world. This study evaluated the type of the psychoactive substances (with or without alcohol) detected in blood samples of drivers involved in traffic accidents in Istanbul and surrounding area.

Materials and methods: The samples from individuals involved in traffic accidents were sent for analysis to the Council of Forensic Medicine-Istanbul Chemistry Department by police or judicial authorities between July 2010 and June 2011. Alcohol analysis was carried out by headspace HS/GC Perkin Elmer Clarus 500 GC TMHS 40. Psychoactive substances were detected using an immunoassay screening (Microgenics' CEDIA Assay kits including Amphetamine/Ecstasy, Benzodiazepines, Barbiturates, Multilevel THC, Cocaine, Methadone, Opiate, TCA Antidepressants on Hitachi 911) followed by LC/MS/MS. Blood samples were subjected to solid phase extraction using Oasis HLB(60 mg) cartridges. Cartridges were conditioned with 1 ml methanol and water respectively. Then 1.5ml blood was passed. Cartridge rinsed by 5% Methanol in water (v:v) and dried. And finally eluted 0.5 ml methanol, 0.5 ml 2% ammonia in methanol (v:v) and 0.5 ml 2% Acetic Acid in methanol(v:v) respectively. Analyses were performed on a Shimadzu LC-20A series system interfaced to a tandem mass spectrometry API 4000 with an electrospray Turbo V™ ion source in negative and positive mode. For positive mode the ESI source settings were ion spray voltage 5500 V, source temperature 500 °C, nebulation and heating gas (N₂), 50 and 50 respectively. For negative mode the ESI source settings were ion spray voltage -4500 V, source temperature 500 °C, nebulation and heating gas (N₂), 50 and 50 respectively. For chromatographic separation polar full endcapped phenylpropyl column was used at 40 °C. A mobile phase of water containing 0.2% formic acid and 2 mM Ammonium Formate (Solvent A) and acetonitrile containing 0.2% formic acid and 2 mM Ammonium Formate (Solvent B) was delivered with the following gradient: starting 10% B at 1ml/min, reaching 90% B in 10 min at 1ml/min, for 5 min 90% B at 1ml/min, back to 10% B in 2.5 min at 0.5 ml/min. Detection of the ions was performed in multiple reaction monitoring (MRM) mode. Analysis of the collected data was carried out by means of Analyst software (Applied Biosystems/Sciex).

Results: Alcohol analysis was requested in 4274 traffic accident cases by legal authorities during this 1 yr period. However, the analysis of psychoactive substances along with alcohol was requested for only 92 cases. Blood analysis in 32 (35.1%) of these 92 suspected cases showed only alcohol; however, in 14 (15.2%) of cases at least one psychoactive substance was identified. There was neither alcohol nor psychoactive substances detected in 45 (49.4%) cases. Out of these 14 cases, in 8 (57.1%) both alcohol and psychoactive substances were identified and in 6 (42.8%) cases there was at least one psychoactive substance without alcohol. THC was the most frequent substance detected (n=8; 57.1%). Benzodiazepines ((n=4; midazolam (n=3) and diazepam (n=1)), pentobarbital (n=2), MDMA (n=1), and cocaine (n=1) were the other identified psychoactive substances in these blood samples.

Conclusions: Analysis for both psychoactive substances and alcohol was requested in only 1.7% of traffic accident cases during the 1 yr investigation period, and fifteen percent of them contained at least one psychoactive substance with or without alcohol. These results indicate that although there are regulations, DUID is not well recognized and not inspected by police and legal authorities who are responsible in routine controls in Istanbul, Turkey. Psychoactive substances should be checked in all traffic accident cases along with alcohol.

Key words: DUID, Drugged Driving, Alcohol

Case Report of Driving Under the Influence of Drugs (DUID) with Mephedrone in France

Cédric Mazoyer*¹, Alexandra Boucher², Yvan Gaillard¹, Fabien Bévalot³, Catherine Lemeur³, Jean-Michel Prevosto⁴, Laurent Fanton⁵

¹Laboratoire LAT LUMTOX, La Voulte sur Rhône, France ; ²Centres d'Evaluation et d'Information sur la Pharmacodépendance, Lyon, France ; ³Laboratoire LAT LUMTOX, Lyon, France ; ⁴Fédération de Biochimie, Hôpital Desgenettes, Lyon, France ; ⁵Institut médico-légal, Lyon, France

Introduction: A 21-year-old man, a regular cannabis user, bought some white powder from a third party. He ingested the powder (an unspecified amount) intranasally, five minutes before driving his car. After less than a kilometer he had an accident in which the car left the road. No other vehicle was involved. When the police officers arrived, the driver was unconscious. He regained consciousness in the emergency vehicle on the way to the local hospital, but didn't remember the accident. A qualitative chemical test of the white powder found in the car was carried out on the spot and was 'positive for amphetamines'. The powder and blood taken from the accident victim were sent to the laboratory.

4-methylephedrone, also known as mephedrone or 4-MMC, is a derivative of methcathinone. Its synthesis was first reported in the 1920s. Mephedrone, a much-discussed topic on internet forums, causes a massive dopamine release in the brain and induces tachycardia, arterial hypertension and peripheral vasodilatation. Users describe it as having ecstasy-like effects, or even as being like cocaine.

Material and methods: The powder was analyzed by gas chromatography-mass spectrometry (GC-MS) with electron ionization mode after acetylation and derivatisation by 2, 2, 2-trifluoroacetic anhydride (TFAA) and led to the identification of mephedrone. Analysis of blood was carried out using liquid-liquid extraction under alkaline conditions with ethyl acetate. Quantification was done on the ion $m/z = 154$ for mephedrone and on the ion $m/z = 157$ for mephedrone-d3 (used as internal standard).

Results:

- Ethanol : Not detected
- **Cannabis:** **THC = 11.5 ng/mL**
11-OH-THC = 10.9 ng/mL
THCCOOH = 84.6 ng/mL
- Cocaine: Not detected
- Opiates : Not detected
- **Amphetamines :** **Mephedrone = 193 ng/mL**
- No other psychotropic drug detected using UPLC-PDA-MS and GC-MS screening

Conclusion: This was the first French DUID case with mephedrone to be reported to the French health agency (AFSSAPS). Together with the present case, six other cases of consumption with deleterious side effects have been reported in France since January 2010. This has led the French Health Ministry to classify mephedrone as a narcotic drug on June 11th 2010.

Keywords: Mephedrone, GC-MS, DUID

Author Name

Abstracts

A

Aarstad, Kjell P034
Abdelmaaboud, Ragaa M. P114
Abraham, Tsadik T. P291
Acar, Fatih **P301**
Acosta, Rafael P077
Adamowicz, Piotr O66, P126
Afxentiou, M. P149
Ahlner, Johan P107, P128,
P150, P151,
P152, P225,
P294
Ahmed, Ashraf Mohamed **P199**
Ahmed, Hatem A. **P114**
Ajenjo, Antonio Castañera P206
Aker, Rezzan Gülhan P191
Akgür, Serap Annette **P211**
Akhmedjanov, Ilhom Gafurovich P214
Aknouche, F. **P111, P242,**
P279
Akrill, Peter **O95, P171**
Akutsu, Mamoru P190
Albarracin-Jordan, Juan O79
Albermann, Maria Elena **P270**
Alexy, Eric M. **P082**
Alford, Ilene P262
Allibe, Nathalie P217
Allorge, Delphine O19, P134,
P230, P265
Almazan, Perla P226
AlSaabi, Alaa **P230, P265**
Alves, Marcela Nogueira Rabelo **P240**
Alzeer, Samar **P231**
Ambach, Lars **P083, P264**
Amira, Dorra **P079**
Anderson, David Wederkinck O96, **P054**
Andreasen, Mette Findal **P287**
Andrenyak, David M. **P098**
Andreuccetti, Gabriel P205, P297
Andrews, Rebecca O50, P022
Anseeuw, Kurt O12
Antonoglou, Georgios P218
Anzillotti, Luca P252, P253

Author Name

Abstracts

Aoki, Rikiya P190
Apple, Fred S. P133
Aqai, Payam O59
Aranda IV, Roman P046, P256
Argo, Antonella P165, P166
Argo, Antonina **O7**
Ariniemi, Kari P038
Arlt, Eva Maria P115
Armato, Ubaldo P042
Armenian, Patil **O22, O99, P172**
Armstrong, E.J. O90
Arndt, Torsten P281
Arnestad, Marianne O20
Arrey, Tabiwang P011
Arun, M. P104
Aşırdizer, Mahmut P191, P301
Ateş, İsmail P301
Athanaselis, Sotiris **P036, P144,**
P145, P146
Augsburger, Marc O53, **O8, P131,**
P288, P295
Auwärter, Volker O33, O63, O70,
P006, P008,
P080, P081,
P197, P221
Avalos, Beatrice P202
Aznar, Gemma O32

B

Bacon, Greg L. O4
Bae, Sue P122
Bagchi, B. P103
Bailey, Kristen M. P088, **P161,**
P164
Baker, Daniel P078, P095
Baker, Daniel D. **P162**
Baker, Ginger L. **P158, P159,**
P160
Baldwin, Dene O82
Ballesteros, Salomé P201
Banaszczyk, Mariusz **P202**
Barhate, Rehka P018
Barbosa de Carvalho, Heráclito **P205, P297**
Barnes, Allan J. A1, A4, O35,
O36, O42, O84,
P291

<u>Author Name</u>	<u>Abstracts</u>	<u>Author Name</u>	<u>Abstracts</u>
Bartoli, Mireille	P217	Bott, Ulrich	P244
Bartolini, Viola	O7, O13, P216	Boucher, Alexandra	P302
Baumann, Stephan Andreas	P056	Boumba, Vassiliki A.	P125, P142
Baumgartner, Markus R.	O78 , O91, P245	Bourland, James	P234
Baylor, Michael R.	O11, P178 , P250	Brailsford, Alan	P277
Beavis, Alison	O89	Breborowicz, Grzegorz Henryk	O80
Beck, Olaf	O30 , O56	Brecht, Volker	P080
Beike, Justus	P061	Brede, Wenche R.	P034
Bell, Richard	P212	Brehmer, Cornelia	P137
Bell, Suzanne C.	P048, P122, P179	Brenneisen, Rudolf	P180
Bello, Stefania	P065	Briellmann, Thomas	P180
Benchikh, M. El Ouard	P222 , P224, P070	Brinkhagen, Linda	O37
Bendary, Ahmed M.	P233	Broecker, Sebastian	O61 , O63, P080
Bender, Katja	P061	Brown, Paul I.	P204
Bengtsson, Finn	P150, P151	Brunet, Bertrand	P153
Benoit, Marc	O39	Brunson, Tara	O68
Bergamaschi, Antonio	P177, P183, P227	Bucaretschi, Fábio	P168, P219
Bergamaschi, Mateus M.	O38	Budin, Nicolas	P040
Bernhard, Werner	P289	Bühr, Claudia	P264
Berry, Jonna	P058	Busardò, Francesco Paolo	O7, P165, P166
Bertol, Elisabetta	O7, O13, P166, P216	Buti, R.	P111, P242, P279
Bertschi, Ingeborg	P180	Button, Jennifer	P116, P136, P292
Betit, Caroline C.	P109, P167	Bynum, Nichole	P182, P250
Bettin, Chiara	P074	Byrska, Bogumila	P192
Bévalot, Fabien	P302		
Bevan, Sian	P260	<u>C</u>	
Beyer, Jochen	O18, O76	Calverley, Richard	P185
Bicker, Wolfgang	P115	Campana, Carmen Cuiza	P269
Bilbault, P.	P213	Campbell, John	P212
Binkley, Joe	P176	Caplan, Yale H.	O29
Binscheck, Torsten	P009, P105	Capriles, Jose	O79
Binz, Pierre-Alain	P040, P180	Carli, Giovanna	P266
Bjork, Marie Kjærgaard	O96, P020	Carlisle, Heidi J.	P210
Blachon, Gregory	P004	Carlsson, Björn	P150, P151
Black, David L.	O29	Carracedo, Angel	O46
Blencowe, Tom	P293	Carrell, Ryan	P086
Blum, L.M.	O90	Carvalho, Heráclito Barbosa	P205 , P297
Boettcher, Michael	P281	Cassidy, Diane	O60
Boggs, P.D.	O90	Castañera, Antonio	P290
Boland, Diane	O44	Castrignanò, Erika	P252, P253
Bonnerup, Spencer	P058	Castro, Catherine	P012, P013, P014, P085
Boone, Carolien	P259		
Borgmeier, Emilee L.	P025	Catbagan, Philip	P012, P013, P014, P085
Bortolotti, Federica	P266		
Bosman, Ingrid J.	P117		

<u>Author Name</u>	<u>Abstracts</u>	<u>Author Name</u>	<u>Abstracts</u>
Cecchetto, Giovanni	O31	Coulter, Cynthia	O25, O64 , P202, P246, P257
Cecconi, Daniela	O31	Countryman, Sky	P030
Cerabino, Maria Luigia	P183, P227	Cowan, David A.	P277, P278
Chambers, Tina	O86	Coward, Samantha	O54
Chandrakant, H.V.	P104	Cox, Susan	P139
Chang, Ning	P086	Coyer, Mike	P076, P092
Chantaksinopas, Kitti	P280	Crawley, Lindsey R.	P046, P256
Chasapi, Anastasia	P040	Crifasi, Joseph A.	P084
Chatkin, José Miguel	P237	Cristina, Keziah	P297
Chatterton, Craig	O83	Croal, Bernard L.	O48
Chatzinikolaou, Fotios	P218	Crumpton, Susan	P182
Cheli, F.	P263	Cruz, Raquel	O46
Chèze, Marjorie	O17		
Chiarini, Anna	P042	<u>D</u>	
Chiarotti, Marcello	P177, P183, P227, P249, P252, P253	Dally, Annika M.	O91, P137
Choe, Sanggil	P138	Dalsgaard, Petur Weihe	O96, P020
Choi, Hwakyung	O24	Dalvi, Aditee P.	P075
Christophersen, Asbjørg Solberg	O27	Danesino, Paolo	O51, P263
Chung, Heesun	O24, P138	Dang, Minh T.	P173
Cintra, Raquel Barbosa	P169	Darragh, J.	P223
Cirimele, Vincent	P254, P255	Davis, Rebecka	P210
Clark, Chantry	P210	Dawson, G. Brent	P073
Clarke, Shannon	P047	de Almeida, Rafael Menck	P021, P135
Clatworthy, Andrew	P292	De Capitani, Eduardo Mello	P168
Clay, David J.	P088 , P161, P164	de Castro, Ana	O74
Clunie, Iain	O48	De Giovanni, Nadia	P121
Cochran, Jack	P092	De Martinis, Bruno Spinosa	P123, P156, P240
Cofino, Julio	O44	De Milia, Maria Grazia	P216
Cohen, Sue	O86	De Nardis, Isabella	P177
Collins, Ayodele	P234	De Paepe, Peter	O12
Collins, Claire	P003, P004	De Spaey, Annelies	P064
Conboy, Marty	O6	De Vincenzi, Eleonora	P227
Cone, Edward J.	O29	Dean, Dorothy E.	P109
Constantinou, M.	P149	DeCaprio, Anthony P.	P039, P066, P089
Conté-Miller, Maria S.	P057	DeCuir, Lynn	O86
Conti, Ario	P131	Déglon, Julien	P005 , P203
Coombes, Gemma	P141, P163	Delannoy, Y.	O19, P134
Cornez, R.	O19, P134	Delaveris, Møller	O20
Cornuz, Jacques	O8	DeOliveira, Stefany	P003, P004
Corvo, Joseph	P082	Deom, André	P180
Coşkunol, Hakan	P211	DePriest, Anne	O29
Cosmi, Erich	O31	Desbrow, Claire	P185
Costa, José Luiz	P168		
Costa, Suzel	P290		

Author Name

Abstracts

Descio, Fernanda Justo P205
Desrosiers, Nathalie A. A1, O3, O42
Deveaux, Marc O17
Deventer, Koen P064
Dhillon, Waljit O50
Di Corcia, D. P110
Di Fazio, Vincent O23, O81
Di Rago, Matthew O76
Diamond, Francis A3
Dias, Mário João P206, P290
Dijkhuizen, Albert P259
Dilek, Isil P026, P045, P086
Dioumaeva, Irina P175
Dixon, Eleanor P043
Dona, Artemis P144, P146
Dona, Artemisia P036
Donze, Nicolas O8, P288
Dougherty, Julieanne P196
Dowling, Geraldine P043, P044
Dowthwaite, Gary P051, P185
Druid, Henrik P128
Drummer, Olaf H. O5, O18, O21, O46,
O76
Dubbelboer, Ilse O30
Duez, Mathieu P255
Dumestre-Toulet, Veronique P241
Duval, H.P. P111
Dyrkorn, Roar P174

E

Easterling, Glenda M. P172, P283, P298,
P299, P300
Eggen, Tormod O20
Eklund, Arne P225
Elian, Albert A. P001
Elliott, Simon O57, O60
Ellis, Elizabeth M. P231
El-Meligy, Manal M. S. P114
Engblom, Charlotta P293
Engelhart, D.A. O90
Enger, Asle O27
Era, Robert P236

Author Name

Abstracts

Erdem, Aslı P211
Eriksson, Peter P285
Erol, Yeter P301
Eschbach, Jörg P273
Eshmuratov, Baltabay A. P214
Espenshade, Jordan P250
Ewald, Andreas O72, P017
Eyraud, M. P242, P279
Eysseric, Helene P217

F

Fábián, Péter A. P037
Fabiani, Maria Claudia de
Mattos P205
Fais, Paolo O31
Falcón, Maria O51
Faller, Andrea P261
Fang, Wenfang B. P062
Fanton, Laurent P302
Farak, Rabie Saad P199
Farrè, Magi O32
Fathy, W.M. P229
Favrat, Bernard O8, P295
Favretto, Donata O28, O31
Felli, Marialinda P177, P183, P227
Ferguson, James L. P178
Ferrara, Santo Davide O28, O31, P274
Ferslew, Kenneth E. A6
Fidder, A. P220
Filippi, C. P263
Filkins, James A. P170
Finnegan, C. P223
Fiore, Carmela P065
Fitzgerald, S. Peter P070, P212, P222,
P223, P224
Fleckenstein, Annette E. P098
Flesch, F. P213
Florek, Ewa O80
Floris, Ivan P184
Fok, Timothy Ho Tong O26
Folker-Calderon, Dawn O39
Forsman, Malin O37
Fraietta, Carmela P183, P227
Franck, Johan O30

<u>Author Name</u>	<u>Abstracts</u>	<u>Author Name</u>	<u>Abstracts</u>
Franckenberg, Sabine	P137	Gnann, Heike	O77 , P261, P273
Frasson, Samuela	O88	Göçer, Yasemin	P191
Freed, Tiffany	P182	Goda, Yukihiro	O65, P072
Friel, Patrick	P078, P095	Goedert, Amy J.	P158, P159
Frison, Giampietro	O88 , P074	Gonmori, Kunio	P101
Fritch, Dean	P047	Gonzales, Elizabeth	P226
Fronterrè, Pietrangelo	P177	Goodwin, Robert S.	A1, O35, O36, O38, O42, P239, P291
Frontz, Michael	P049	Gordon, Ann M.	O69 , O85, O99, O106, P172, P283, P298, P299, P300
Frost, Joachim	O49 , P127	Gorelick, David A.	A1, A4, O3, O10, O35, O42, O75, O84, P291
Fu, Shanlin	O89, O97, P053	Gorniak, Jan M.	P162
Fucci, Nadia	P121	Gosset, D.	O19, P134
Fuchigami, Yuki	P068 , P069	Gottardo, Rossella	P042
Fujii, Hiroshi	P010 , P190	Goulart, Ana Paula Szezepaniak	P237
Fukada, Masakatsu	P190	Grabenauer, Megan	P193
Fukuhara, Kiyoshi	O65	Graf, Kristopher W.	A2
Fukushima, Hirofumi	P033	Grata, Elia	O58
Fuller, Kathryn	P058	Green, Felicia	O94
Fürmanova, Vilma	P091, P093	Green, Henrik	P150, P151
Fusini, M.	P263	Greggio, Maria	O88, P074
		Grieve, James H.K.	O48
G		Grimm, Ulfert	P245
		Grivet, Chantal	O62
Gaillard, Yvan	P302	Grobosch, Thomas	P009 , P105
Gambaro, Veniero	P165	Groppi, Angelo	O51, P147, P148, P263
Gammelgaard, Bente	P020	Gruber de Oliveira, Barbosa	P297
Garcia-Algar, Oscar	O32, O51	Guale, Fessessework	O86
Garnier, Margaux	O25, O64, P202, P246 , P257	Gubanich, K.M.	O90
Gaulier, Jean-Michel	P230	Guerrini, Katia	P165
Gautam, Lata	P282	Guibert, E.	P111, P242, P279
Gavrilović, Ivana	P277	Guice, Erica A.	P025 , P027 , P267
Gebhardt, Myron A.	P088, P161, P164	Gülhan, Rezzan	P301
Gerace, E.	P110	Gunnar, Teemu	P186 , P285
Gergov, Merja	O74	Gürdal, Fatma	P191
Gerona, Ray R.	O69		
Gerona, Roy RL	O16		
Gerostamoulos, Dimitri	O18, O21, O46, O76		
Gerssen, Arjen	O59		
Gesteira, Alejandro	O46		
Gianvecchio, Victor Alexandre P.	P135		
Gibb, James W.	P098		
Gluodenis, Tom	P077		

Author Name

Abstracts

H

Haasnoot, Willem	O59
Hackett, Jeffery	P001
Hadlock, Gregory C.	P098
Haglock, Carrie J.	P215
Hahn, Roberta Zilles	P168
Haikal, Nabila A.	P164
Häkkinen, Margareeta	O47
Hallbach, Jürgen	O15
Han, Eunyoung	P138
Hanna, Jerome	P217
Hansen, Tina Maria	O9
Hanson, Glen R.	P098
Hara, Kenji	P010
Hardwick, Sheila	P096
Harmes, David Christopher	P058
Hart, Amy P.	O69, O85
Härtel, C.	P194
Hartman, Rebecca L.	A1, O42
Hasegawa, Koutaro	P101
Hashimoto, Hiroaki	P033
Hashimoto, M.	P007
Hashimoto, Y.	P007
Hasselstrøm, Jørgen	P287
Hasvold, Inger	O20
Hattori, Hideki	P055
Haukka, Jari	P285
Havaçeliği, Demet	P211
Hayashi, Takeshi	P155
Hayward, Verity	P116, P163
He, Xiang	P236
Hearn, W. Lee	O44
Hebert, Normand	P202
Hédouin, V.	O19, P134
Heffron, Brendan	O39
Heim, John	P176
Helander, Anders	O56
Heleni, Zagelidou	P218
Helland, Arne	P127
Heltsley, Rebecca	O29
Hennart, Benjamin	P265
Henschel, Birgit	O15
Hermanns-Clausen, Maren	P081, P221

Author Name

Abstracts

Herndon, Robert L.	P132
Herre, Sieglinde	O61
Herreño-Sáenz, Diógenes	P057
Hess, C.	O101
Hidvégi, Előd	P037
Himes, Sarah K.	P239
Hirano, Seishiro	P002
Hirvonen, Jussi	O36, O38
Hjelmeland, Knut	O27
Ho, Chung Shun	O26
Hockenhull, Joanna	O50
Hoizey, Guillaume	O17
Hokamp, Eva Grosse	P244
Holmes, P.	P223
Holmgren, Anita	O102, P107
Holt, David W.	P094, P116, P136, P141, P163
Hong, Hyojeong	P138
Honnold, Ron	P077, P084
Hook, James	O97
Hopf, Markus	P017
Hopfgartner, Gerard	O62
Horna, Ales	P268
Huaita, Dóris Sandra Uria	P269
Hudson, William	P175
Huestis, Marilyn A.	A1, A4, O3 , O10, O35, O36, O38, O42, O75, O84, P239, P291
Hughes, John	O86, P175
Hulst, A.G.	P220
Humbert, Luc	O19, P134, P140
Hurme, Jukka	P286
Hutter, Melanie	O63 , O67
Huynh, Kim	P018
Hwang, Rong-Jen	P158, P159, P160

Author Name

Abstracts

I

Iannello, G.	P263
Ibragimova, Mareta M.	P015, P016, P119 , P214
Igarashi, Kazuo	P155
Ikeda, Rie	P068, P069 , P258
Ikramov, Latif Tulyaganovich	P016, P214
In, Moon Kyo	P188
In, Sanghwan	O24
Ingels, Ann-Sofie	O12
Ingle, Eric A.	O106 , P172, P283, P298, P299, P300
Innocenzi, P.	P070
Inokuchi, Sadaki	P019, P238
Inoue, Hiroyuki	P007, P033 , P087
Ishii, Akira	P055
Iskhakova, Saida S.	P015, P016
Isono, Kazutomo	P258
Iwata, Yuko T.	P033, P087

J

Jamey, C.	P213
Janer-Figueroa, Jeanette	P057
Jantos, Ricarda	P209
Jellick, Greg	P049
Jenkins, Amanda J.	P112
Jeong, Sujin	P138
Jian, Huahua	P026 , P045
Jochum, Nadine	P017
Johannessen, Ludvig	P174
Johansen, Sys Stybe	O9
Johansen, Unni	O27
Johnson, Rolley E.	P239
Johnson-Davis, Kamisha L.	P204
Johnston, Atholl	P094, P141, P163
Jones, Alan Wayne	O102 , P107
Jones, Arthur	P196
Jones, Gavin	P050, P051, P052
Jones, Hendrée E.	P239
Jones, Kate	P116
Jones, Rhys	P044, P050 , P051, P052 , P185

Author Name

Abstracts

Joosen, Marloes	O93
Jordan, Steve	P050, P051, P052, P185
Jorunn, Gerd	O20
Josefsson, Martin	P124 , P150
Juebner, Martin	P061
Juenke, JoEtta M.	P204
Juhascik, Matthew P.	P112
Jurado, Carmen	P247

K

Kacinko, Sherri L.	A2, O71
Kaferstein, Herbert	P061
Kahler, Ty	P076, P092
Kanamori, Tatsuyuki	P033, P087
Kanari, P.	P149
Kanchan, Tanuj	P102
Kaneko, Rina	P055
Kanno, Sanae	P002
Kano, Koji	P238
Kaplan, James A.	P161
Kaplan, Kimberly	P046 , P256
Karamanidis, Pavlos	O85 , P172, P283, P298, P299, P300
Karampela, Sevasti	P036
Karch, Steven B.	O13 , P065 , P216
Karlsson, Louise	P150 , P151
Karschner, Erin L.	O10 , O38, O75
Karst, U.	P194
Karttunen, Åse	P186
Kashiwagi, Masayuki	P010
Kataoka, Tadashi	P190
Kawaguchi, Akira T.	P238
Kawamura, Maiko	O65, P072
Kawase, Yasuharu	P190
Kearney, Thomas E.	O99
Keller, Thomas	P115 , P281
Kelly, F.M.	P223
Kelly, Tamsin	O89, P196
Kennedy, Paul	P076, P092
Khan, Azeem M.	O55
Kharbouche, Hicham	O8, O53
Khasanov, Usman	P015 , P016

<u>Author Name</u>	<u>Abstracts</u>	<u>Author Name</u>	<u>Abstracts</u>
Kiat, W.K.	P200	Küçükibrahimoğlu, Esra	P191, P301
Kicman, Andrew T.	O94, P277, P278	Kuffer, Hans	P180
Kikura-Hanajiri, Ruri	O65 , P072	Kugelberg, Fredrik C.	O37, P150, P151 , P294
Kim, Eunmi	O24 , P138	Kula, Karol	P129
Kim, Jihyun	O24	Kulza, Maksymilian	O80
Kim, Min Kyoung	P188	Kunes, Jiri	P091
Kintz, Pascal	O45 , P111, P143, P247	Kuoppasalmi, Kimmo	P285
Kirkovits, Greg	P086	Kurahashi, Kazumi	P190
Kitagishi, Hiroaki	P238	Kuroda, Naotaka	P068, P069, P258
Kloss, Julie	P133	Kuwayama, Kenji	P033, P087
Kluge, Matthias	P261	Kuzushima, Miki	P069
Klys, Malgorzata	P129 , P195		
Kneisel, Stefan	O63, O67, O70 , P080 , P081 , P197	L	
Knight, Jonas E.	P172, P283, P298, P299 , P300	Labay, Laura M.	P082
Ko, Beom Jun	P188	Lambert, Willy	O12
Kocur, Sean E.	P075	Lanaro, Rafael	P168 , P219, P228
Koenig, Nadine	P047	Langel, Kaarina	P038, P293
Koenig, Patrick	P261	Langenberg, Jan P.	O14, O93
Köhler, Christoph	P009	Laserna, José Daniel Bogado	P269
Köhler, Helga	P207	Latawiec, Adam	P276
Koin, Peter J.	P170	Latino, Anna	O8
Kolbrich-Spargo, Erin A.	A1, O35, O42, P291	Latyshev, Sergey	P226
Kolocassidou, N.	P149	Lauer, Estelle	P005, P203
Konari, K.	P149	Launiainen, Terhi	O47
König, Stefan	O52, P264, P289	Lavins, E.S.	O90
Kopf, Gregor	O61	Law, Emmett Wai Keung	O26
Korkut, Şenol	P191	Lawrence, Katie Laura	P271
Koskimaa, Heikki	P285	Layne, Jeff	P030
Koukou, Alexia	P248	Le, Anh	P243
Kourkoumelis, Nikolaos	P125	LeBeau, Marc A.	O1, P046, P256
Kozak, Marta	P236	Lechowicz, Wojciech	O80, P031
Kraemer, Thomas	O62 , O78, O91, P137, P245	LeCount, Jane	P032
Kramer, Jan	P286	Lee, Dayong	A4 , O3, O84
Kraner, James C.	P088, P161, P164	Lee, Ngak Lee	P035
Kriikku, Pirkko	P286	Lee, Rob	P032 , P181
Krol, Wojciech	P193	Lee, Sangki	P138
Kronstrand, Robert	O37 , P128, P152, P294	Lee, Sooyeun	O24
Kubo, Shin-ichi	P010	Lee, Terry D.	P141
		Legrand, Sara-Ann	O2

<u>Author Name</u>	<u>Abstracts</u>	<u>Author Name</u>	<u>Abstracts</u>
Lemour, Catherine	P302	Lui, Chi Pang	P035
Lemos, Nikolas P.	O22, O69, O85, O99, O106, P172, P283, P298, P299, P300 P061	Luiz da Costa, José	P021, P219 , P228
Lenz, Daniel	P035	Luna, Aurelio	O51
Leong, Huey Sze	O40, P064	Lundström, Charlotte	O37
Leroux-Roels, Geert	P182 , P250	Lung, Derrick D.	O99
Lewallen, Cynthia	P053	Luong, Susan	O97
Lewis, John	P296		
Lewis, Kenneth	P135, P169 , P205, P297	M	
Leyton, Vilma	O19, P140	Machado, Julia de Barros	P237
Lhermitte, Michel	P243	Macherone, Anthony	P077 , P084
Li, Wen	P059, P060	Maciów, Martyna	P195
Liang, Chen	O20	Madea, Burkhard	O101, P118, P270
Lilleng, Peer	P038 , P293	Madry, Milena M.	P137, P245
Lillsunde, Pirjo	P113	Madsen, Kathrine Asberg	P020
Lin, Dong-Liang	P187	Maerrawi, Ilham El	P205
Linden, Carl A.	P168	Magnavita, Nicola	P177
Linden, Rafael	O96, P054, P120	Mahler, Hellmut	P006
Linnet, Kristian	P058	Mahmoud, Hamada E.	P088
Liskutin, Tomas	O100	Maignant, V.	P111, P279
Litwin, Craig M.	P113	Mala, Sima	O54
Liu, Hsiu-Chuan	P041, P071 , P073	Mangin, Patrice	O8, O53, P005, P203, P288, P295
Liu, Hua-fen	P026	Marchei, Emilia	O32
Liu, Martha	P067	Marclay, Francois	O58
Liu, Meili	P113	Marek, Elizabeth	P045
Liu, Ray H.	P149	Maresi, Emiliano	P165
Liveri, K.	P168	Mari, Francesco	O7, O13, P166, 216
Lizot, Lilian de Lima Feltraco	P278	Marinetti, Laureen	P154
Lobo Vicente, Joana	P051, P185	Marsh, Jessica M.	P025
Lodder, Helen	A2, A3, O71	Marshall, Lucas	O29
Logan, Barry K.	O31	Marsili, Remo	P121
Lonardonì, Francesco	P084	Martello, Simona	P177, P183, P227
Long, Christopher W.	P225	Martin, Mathieu	P254, P255
Lood, Yvonne	P040 , P064	Martin, Rafaela	P207
Lootens, Leen	P268	Martindale, Stephanie	P122
Loucka, Peter	P123, P157	Martínez, María Antonia	P201
Louzada de Paula, Daniela M.	P224	Martinez, Rosita	P137
Lowry, Michelle	P070, P222, P224	Martz, Walter	O100
Lowry, Philip	P078, P095	Masselot, Alexandre	P040
Lu, Guiping	P113	Master, Adolfo Arturo M. Millán	P269
Luan, Hsin-Yun	P116	Mastrogianni, Orthodoxia	P218, P248
Lucas, Sebastian	P213	Matoba, Ryoji	P155
Ludes, B.			

<u>Author Name</u>	<u>Abstracts</u>	<u>Author Name</u>	<u>Abstracts</u>
Matsusue, Aya	P010	Miyaguchi, Hajime	P033, P087
Maurer, Hans H.	O34, O35, O87, O92	Mikazaki, Shota	P019
Mazoyer, Cédric	P302	Mizuno, Tomomi	P190
Mazzola, C.D.	O90	Moffatt, Ellen	O85
McCance-Katz, Elinore	P062	Mohr, Carolina	P237
McCluskey, Clare	P198	Mollica, Roberto	P249, P252
McConnell, R.Ivan	P070, P222, P223	Montgomery, Madeline A.	O1 , P046, P256
McCutcheon, J. Rod	P049	Montgomery, Matthew	P027, P267
McDonnell, R. Ivan	P224	Monticelli, Fabio	P115
McDonough, Michael	O21	Moody, David E.	P062 , P210, P215
McFarlane, John	P276	Moore, Christine	O25 , O64, O79, P012, P014, P018, P202, P246, P257
McGivern, Paul	P212		
McGuire, Calvin E.	P162		
McKay, Linda	O48	Moore, Katherine	O11
McKeown, Denise	P136	Moosmann, Bjoern	P197
McLaughlin, Poppy A.	P139	Moreira de Mello, Sueli	P168
McMillin, Gwendolyn A.	P204, P210, P215	Morelli, Matteo	P249
Meadors, Viola M.	O29	Morini, Luca	O51, P263
Medina, Cecilia O.	P172, P283, P298 , P299, P300	Mørland, Jørg	O20
Mejorado, Lupe	P202	Morokuma, H.	P007
Meléndez-Negrón, Margarita	P057	Morrison, Jerdravee	P062
Melinek, Judy	O69	Mortali, Claudia	O32
Mello De Capitani, Eduardo	P219	Mozayani, Ashraf	O86
Mello, Marcos Fernando Santos	P168	Muckenstrum, Aurélie	O17
Mendonça, Josidéia Barreto	P123, P157	Mukai, Toshiji	P002
Menck de Almeida, Rafael	P135	Müller, L.	P194
Menzies, Eleanor	O94	Muñoz, Daniel Romero	P169, P297
Merová, Barbora	P024	Mura, Patrick	P153
Merritt, Paola	P234	Mürdter, T.	O67
Meuleman, Philip	O40, P064	Murphy, Alan	P043
Meyer, Golo M.J.	O34	Murphy, William	P003, P004
Meyer, Markus R.	O34, O35, O87, O92	Musshoff, Frank	O101, P011, P118 , P244, P270
Middelkoop, Gerrit	O20		
Middleton, Owen	P133	Mykkänen, Sirpa	P186
Mikel, Charles	P226	Mylonakis, Panagiotis	P218
Miller, F.P.	O90	Mylonas, Roman	P040
Miller, Mark L.	P046, P256		
Miller, Melanie Jayne	O79		
Milman, Garry	A4, O3, O36 , O84		
Milsom, Anna	O94		
Minakata, Kayoko	P101		
Minar, Jakub	P268		
Minty, Peter	P136		
Mitchell, John M.	O11, P178, P182, P250		

Author Name

Abstracts

N

Nakamoto, Akihiro	P019
Nakashima, Kenichiro	P068, P069, P258
Nakazono, Yukiko	P033
Nalesso, Alessandro	O28, P274
Namera, Akira	P019
Naso, C.K.	O90
Neels, Hugo	O12
Negrusz, Adam	O39
Neri, Margherita	P065
Neukamm, M.A.	O67
Newland, Gregory	P041, P047
Newsome-Sparks, Christina L.	P088, P161, P164
Ng, Patrick S.	P170
Nguyen, Phung	P243
Ni, Chunfang	P059
Nieć, Dawid	P031
Nielen, Michel W.F.	O59
Nikolaou, Panagiota	P144, P145
Nilsson, Gunnel H.	P294
Nishikawa, Rona K.	P048
Nomura, Mina	P055
Noort, Daniel	O14 , O93, P220
Nordrum, Ivar S.	O49, P127
Norris, R.N.	O90
Notebaert, Delphine	P265
Nozawa, Hideki	P101
Nyström, Ingrid	O37

O

Ochi, Hiroshi	P155
Ogawa, Tadashi	P055
O'Hehir, C. Meagan	A3
Øiestad, Elisabeth Leere	O20, O27
Oikawa, Hiroshi	P019
Ojanperä, Ilkka	O47 , O73, O74, O105, P286
Okai, Guilherme Gonçalves	P021
Okuda, Haruhiro	O65
Oldfield, Lucy S.	P179
Oles, Monique A.	P112

Author Name

Abstracts

Oliveira, Carolina Dizioli Rodrigues	P021
Ollerton, Samantha	O94
Olson, Kalen N.	P133
Ondra, Peter	P024, P208
Ondrová, Dana	P208
Oosting, Roelof	P259
Orbita Jr., Jonathan	O25, O64, P257
Orfanidis, Amvrosios	P248
Orsulak, P.	P070
Osculati, Antonio	P131
Osselton, Michael David	O82, P135, P139
O'Sullivan, John	P260

P

Pacifici, Roberta	O32
Palicka, Vladimir	P091, P093
Palma, Gennaro	P183, P227
Palmbach, Timothy M.	P266
Panopoulos, Andreas	P231
Papaseit, Esther	O32
Papet, Yves	P153
Papoutsis, Ioannis	P036, P144, P145
Park, Alexandra	O54
Parkin, Mark C.	O94
Pascali, Jennifer P.	P249
Paterson, Sue	O50, P022
Peace, Michelle	O11
Pelander, Anna	O73, O74
Pelição, Fabricio Souza	P123 , P157
Pélissier-Alicot, Anne-Laure	O17
Pellegrino, S.	P251
Pentis, Matthew W.	P028
Penttilä, Antti	P285
Pépin, Gilbert	O17
Peres, Mariana Dadalto	P156, P157
Perrenoud, Laurent	O58
Perry, Fiona	P136
Pesce, Amadeo	P226
Peters, Benjamin	O72
Peters, Frank T.	O43
Petersen, Diana Ina	P020
Philippe, Olivier	P040

<u>Author Name</u>	<u>Abstracts</u>
Pianca, Dennis	P196
Picard, Nicolas	P230
Picard, Pierre	P003, P004
Piccinotti, Alberto	P184
Pichini, Simona	O32 , O51
Piekoszewski, Wojciech	O80
Pierpaola Dal Prà, Ilaria	P042
Pike, Erica	P030
Pilgrim, Jennifer Lucinda	O46
Pinorini-Godly, Maria Teresa	P131 , P288
Piper, M.	P223
Pirro, V.	P251, P272
Pissinate, Jauber Fornaciari	P123, P157
Pistos, Constantinos	P036, P144, P146
Pohludka, Michal	P268
Poklis, Alphonse	P079
Poklis, Justin L.	P079
Polesol, Daniel Ninello	P228
Polettini, Aldo	O55 , P184
Politi, Lucia	P216
Pollard, J.	O19, P134
Poloni, Vala	O55
Pomara, Cristoforo	P065
Ponce, Julio de Carvalho	P169
Porta, Tiffany	O62
Portman, Maria	P285
Pounder, Derrick J.	P139
Pour, Milan	P091
Powles, Paul	P260
Pozzi, F.	P147, P148
Pragst, Fritz	O61
Preidel, Andreas	P281
Prevosto, Jean-Michel	P302
Pricone, Maria Grazia	O21
Procaccianti, Paolo	P165, P166
Pсарos, Georgios	P248
Puchnarewicz, Malgorzata	P094 , P116, P136, P141 , P163
Puhakainen, Eino	P186
Pütz, M.	P194

<u>Author Name</u>	<u>Abstracts</u>
Q	
Quarino, Lawrence	A5
Quatrehomme, G.	P111
Queiroz, Luciano de Souza	P168
Queiroz, Rigina H.C.	O38
R	
Raikos, Nikolaos	P218 , P248
Ramirez, Jorge A. Martinez	O43
Ramsey, John	P094
Rana, Sumandeep	O68 , P097, P099
Rasanen, Ilpo	O105
Rasmussen, Brian Schou	O96 , P020, P054
Rasulev, Ukur K.	P016
Ratcliffe, Peter	P222
Razatos, Gerasimos	P159
Reda, Louis J.	O1
Redondo, Ana Hernández	O52 , P264
Regan, Liam	P043, P044
Rehder-Silinski, Melanie	P182
Reichardt, Eva M.	O82
Reimers, Arne	P174
Rentsch, Katharina	P180
Rhee, Jongsook	P138
Richards-Waugh, Lauren L.	P088, P161, P164
Richeval, Camille	P140
Richter, Barbara	P261
Riezzo, Irene	P065
Rigdon, Amanda	P076 , P092
Rimondo, Claudia	P042
Rintatalo, Janne	P286
Rivera, Jeffery	P041
Robert, Tim	O29
Robino, Allison	P266
Rock, Colleen M.	P239
Rode, Andrej Jaroslav	P020
Rodrigues, Karine	P237
Rodrigues, Warren C.	P012 , P013 , P014 , P018 , P085
Rofe, Karen	P096 , P198
Rohde, Douglas E.	P108
Rojek, Sebastian	P129, P195

Author Name

Abstracts

Roman, Markus P124
Ropero-Miller, Jeri D. O11, P182, P250
Roque, José P259
Rosano, Thomas G. **O104**
Rosendal, Ingrid P287
Rosenthal, Murray P226
Ross, Wayne B. O68, P097, P099
Roth, Nadine O33, **P008**
Rothschild, Markus A. P061
Rowsell, Donna May **P271**
Ruiz, Yarimar O46
Rummel, Michael **P030**
Rusca, C. P263
Rusconi, Manuel P131
Rust, Kristina Y. O78, **O91**, P245
Ruyay, James O25
Rzepecka-Woźniak, Ewa P129

S

Saar, Eva **O18**
Sachs, Hans O67, P247
Sadjadi, Seyed **P030**
Şahin, Ayşegül P301
Sahu, Chittaranjan **P103**
Saito, Takeshi **P019**, P238
Salomone, Alberto O55, P110, **P251**,
P272

Samyn, Nele O23, O81
Sandquist, Sören O30
Santoro, Paolo Emilio **P177**, **P183**, **P227**
Sarker, Protiti P160
Saugy, Martial O58
Sauvage, François-Ludovic P230
Schäfer, Nadine **O72**
Scheidweiler, Karl B. A1, O42, O75, **P291**
Schmidt, Michelle L. **A5**
Schmitz, Wagner P297
Schneider, Kevin J. **P066**
Scholer, André P180, P281
Schumacher, Markus P209
Schürch, Stefan P264
Schürenkamp, Jennifer P207
Schwaninger, Andrea E. O34, **O35**, O92

Author Name

Abstracts

Schwarze, B. P105
Schwope, David M. A4, O3, O10, **O75**,
O84
Sciarrone, Rocco O88, P074
Scott-Ham, Michael P292
Sears, Robert M. **P296**
Seidel, Catharina O61
Seitz, Helmut K. P261
Seldén, Tor **P128**
Sell, Joann P047
Seńczuk-Przybyłowska, Monika **O80**
Senior, Adam P051
Seno, Hiroshi P055
Seri, Catia P042
Serpelloni, Giovanni P042, P249, P252
Seulin, Saskia Carolina P135
Shahreza, Shahriar O86
Shakhitov, Makhmudjan M. P015, P016
Shan, Xiaoqin **P262**
Sharratt, Sarah P282
Sheedy, Alixe P108
Shishika, T. P007
Shoda, Takuji O65
Sigurdardottir, Stella Røgn O96
Silva, Ovandir A. O98
Silva-Torres, Luz A. **P057**
Simões, Susana Sadler **P206**, P290
Simons, Brian **P154**
Simons, Stacey O44
Simonsen, Kirsten Wiese O96, P020
Simpson, William G. O48
Sinagawa, Daniele Mayumi P169, **P297**
Skopp, Gisela P209, P261
Sleeman, Richard O94
Slopianka, Markus O66, P126
Slørdal, Lars O49, P127
Smink, Beitske P259
Smollin, Craig O16
Snell, K.D. O90
Snenghi, Rossella P274
Soares, James P012, P013, P014,
P018, P085
Sofalvi, S. O90
Soliman, Wagdy Abdelmeged **P063**
Somogyi, Gábor P037

Author Name

Abstracts

Sørensen, Lambert K. P090
Sorio, Daniela P266
Spagou, Konstantina P218
Spera, Joseph A3
Spiehler, Vina P171
Spigset, Olav P174
Spiliopoulou, Chara P036, P144, P145, P146

Spinelli, Mario O55
Spirk, Michelle A. O4
Sporkert, Frank O8, O53, P131, P288, P295

Sreenivasan, Uma P026, P045, P086
Stanaszek, Roman P126
Stanke, Françoise P217
Staňková, Marie P024
Staub, Christian O53, P005, P203
Stauffer, Melanie P047
Stefanidou, Maria P144, P145, P146
Stein, Elliot A. O42
Steiner, Robert O11
Stephen, Duncan W.S. O48
Stibley, J.M. O90
Stocchero, Giulia O28
Stoecklein, D. P105
Stojanovska, Natasha O89
Stoll, Dwight R. P058
Stout, Peter R. O11, P182, P250
Stove, Christophe O12
Stowell, Allan O54
Stramesi, C. P147, P148
Strano-Rossi, Sabina P249, P252, P253
Ström, Lena P124
Strona, Marcin P129
Strupat, Kerstin P011
Sugimoto, Yuki P258
Suh, Sungill P188
Sukta, Andre O39
Suman, Priya P136
Suriya, Piyamas P280
Suzuki, Osamu P002, P101
Suzuki, Yudai P055
Swift, Thomas A. O104
Swortwood, Madeleine P089

Author Name

Abstracts

T

Taddei, Lisa O39
Tafarli, Theodora P218
Tagliaro, Franco P249, P252, P266
Tahtouh, Mark O89
Takagi, Toshiyuki P190
Tameni, Silvia P184
Tang, Francis P.W. O41
Tavares, Marina Franco Maggi P228
Tawil, Nadia O98
Taylor, Adrian P276
Taylor, Kerry O60
Taylor, S.M. O90
Telepchak, Michael J. P001
Tell, Helena P124
Terranova, Claudio O28, P274
Thelander, Gunilla P152
Theodoridis, Georgios P218, P248
Thierauf, Annette O77, P261, P273
Thiesen, Flavia Valladão P237
Thomas, Aurélien P005, P203
Thomas, Brian F. P193
Thomas, Jérémy P265
Thomas, Ronald L. P204
Thompson, Vanessa P039
Tipparat, Prapatsorn P280
Tiscione, Nicholas B. P262
Toivola, Bert P078, P095
Tokarczyk, Bogdan O66, P126
Tokieda, Yoshio P190
Tolliver, Samantha O44
Töpfer, Nicole P221
Torres-Hernández, Bianca P057
Tournel, Gilles O19, P134, P140, P230, P265

Tournoud, C. P213
Tracqui, A. P213
Traficante, Louis J. P075
Tran, Chau P243
Trass, Matthew P030
Traynor, Allan P032, P260
Tremblay, Patrice P003, P004
Tsoukali-Papadopoulou, Heleni P248

Author Name

Abstracts

Tsui, Teresa Kam Chi O26
Tsujikawa, Kenji P033, **P087**
Tsumura, Yukari P190
Tucci, Marianna O31, P274
Tung, Jim K.K. P243
Turner, Kirsten **P254, P255**
Tuyay, James O64, P257
Tyrkkö, Elli **O73**

U

Uchiyama, Nahoko **P072**
Uges, Donald **O25**
Uralets, Victor **P097, P099**
Uria Huaita, Dóris Sandra **P269**
Usmanov, Dilshadbek T. P015, P016
Uusivirta, Hannu P038

V

Vallet, Emilie P254, P255
van den Berg, Roland O93
van der Linde, Susanne O25
van der Schans, Marcel **O93, P220**
Van Eenoo, Peter O40, P064
van Leeuwen, Arthur O25
Van Sassenbroeck, Diederik O12
Varango, C. P263
Vardakou, Ioanna P036, P146
Varesio, Emmanuel O62
Varlet, Vincent P295
Vasiliadis, Nikolaos P218
Vaucher, Paul O8
Versace, François P203
Verstraete, Alain **O2**
Vevelstad, Merete **O20**
Viel, Guido O28, O31, P274
Vignali, C. **P147, P148**
Viinamäki, Jenni **O105**
Villain, Marion O45, **P143**
Vincent, Michael P014, P018, P085
Vincenten, Rianne P117
Vincenti, M. P110, P251, P272

Author Name

Abstracts

Vindenes, Vigdis O27
Visentin, Silvia O31
Vogliardi, Susanna O28
Voigt, K. O43
Volk, Justin A. O85, P172, P283, P298, P299, **P300**

Vollmar, Christian O92
von Brand, Andrew P178
von Meyer, Alexander O15
Vonlanthen, Bruno P137
Vorisek, Viktor **P091, P093**
Vougiouklakis, Theodore P125, P142
Vuori, Erkki O47, O105

W

Wada, Mitsuhiro P068, P069, P258
Wade, Norman A. P132
Walsh, J. Michael P178
Wan, Terence S.M. O41
Wang, Alexandre **P041, P071, P073**
Wang, Guohong P012, P013, P014, **P018, P085**

Wang, Huiying **P243**
Wang, Rong P059, P060
Wang, Yujin **P067, P130**
Ward, Conor **P029**
Wark, Gwen P141
Watanabe, Kanako P101
Watanabe, Kenji P238
Waters, Brian P010
Watterson, James H. P109, P167
Weber, Armin A. O87
Wei, Zhiwen **P130**
Weinmann, Wolfgang O52, O77, P083, **P264, P273, P289**

West, Cameron P226
West, Robert **P226**
Westin, Andreas A. P127
Westphal, Folker P080
Whitter, Paul P049
Wiert, Jean François O19, P134, P140
Wiebelhaus, Jason M. P079

Author Name

Abstracts

Wilhelm, Lars P286
Wilkins, Diana G. P098, P239
Wilkins, L.D. O90
Wille, Sarah M.R. **O23**, O81
Williams, Chinyere M. O85, P172, **P283**,
P298, P299, P300

Williams, Lee P044, P050, **P051**,
P052, **P185**

Winkler, Michaela P261
Wintermeyer, Annette P061
Wise, Laura E. P079
Wissenbach, Dirk K. O34, **O87**
Wittmann, Helmut P115
Wohlfarth, Ariane **O33**, **P006**, P008,
P221

Wolf, Ehud (Udi) O92
Wong, Anthony **O98**
Wong, Beckie P243
Wong, Jenny K.Y. **O41**
Wong, Raphael C. O26, P243
Woo, Sanghee O24
Wood, Michelle O104, P032, P181
Workman, Heather L. P025, P027, P267
Woronicieki, Witold P041
Wort, Catherine J. O76
Wright, Trista H. **A6**
Wu, Alan H.B. O16, O69
Wyman, John F. **O90**, P109

Y

Yamada, M. **P007**
Yamagishi, Itaru P101
Yamagiwa, Takeshi **P238**
Yao, Yi Ju P035
Ye, Haiying P059, P060
Yeakel, Jillian A3
Yeatman, Dustin Tate P262
Yeom, Hyesun P138
Ying, Yunming P086
Yokokura, T. P007
Yonamine, Mauricio P021, P135, P297
Yücetürk, Burcu P211
Yun, Keming **O103**, P130

Author Name

Abstracts

Z

Zackrisson, Anna-Lena P150, P151, **P152**
Zagelidou, Helini P248
Zahlsen, Kolbjørn P034
Zamengo, Luca O88, P074
Zancanaro, Flavio O88, P074
Zanchetti, Gabriele P184
Zerbini, Talita P169
Zhang, Runsheng P060
Zhang, Yun P067
Zhang, Yurong **P059**, P060
Zhao, Weping P071
Zheng, Yufang O56
Zhu, Mingshe P071
Zuba, Dariusz P192

Keywords

β -Glucuronidase	P053
Δ^9 THC-D ₃	P008
Δ^9 -Tetrahydrocannabinol	P022
(-)- Δ^9 -Tetrahydrocannabinolic Acid A	P006
Δ^9 -Tetrahydrocannabinol	O38
Δ^9 -Tetrahydrocannabinolic acid A	O33
1-(3-trifluoromethylphenyl) Piperazine (TFMPP)	O85
1,4- Butanediol	P061
1,5 Anhydroglucitol	O101
1-Hydroxypyrene	P237
2-Amino-5-Chloropyridine	P294
2-DE Gel	O31
4-Methylmethcathinone (Mephedrone)	O89, P091
6-Acetylmorphine	P132, P182

A

ABCB1	P150
Abuse	O102
Accident	P142
Accurate Mass	O61, P040
Acetaminophen	P212
Acetylation	P132
Aconitine	P115
ACTP-Ester	P103
Adamantoyl Derivative	P080
Addiction	P295
Adulteration	O97, P210
Advanced Toxicology	P025
Adverse Drug Reaction	O46
Agouti-Related Protein	P229
Alcohol	O48, P067, P157, P169, P269, P271, P273, P278, P301
Alcohol Abuse	P272, P274
Alcohol Biomarker	O56, P268
Alcohol Marker	O77
Alcoholic Ketoacidosis	O50, P117
Aldehyde Dehydrogenase	P061
Alkaloids	O57

Abstracts

Keywords

Alternative Matrices	P153
Alternative Samples	P139
Aluminum Phosphide	P104
Amatoxins	P024, P055
Aminoalkylindoles	P081
Aminorex	O13, P216
Amlodipine	P136
Amobarbital	P030
Amphetamine(s)	O102, P033, P037, P050, P243
Anabolic Androgenic Steroids	P225
Anabolic Steroids	O39
Analysis	P038
Analytical Reference Materials	P045
Analytical Validation	P158, P160
Annual Assessment of Needs	P173
Antemortem	P262
Anti-Arrhythmic	P204
Antibodies	P070, P222
Anticonvulsants	P031
Antidepressant	P110
Anti-Diabetic Drugs	P214
Antidiabetics	P016
Antidote	P238
Antihistamine	P014
Archaeology	O79
Argon	P118
Arteriosclerosis	P143
Atmosphere-Pressure Thermo Desorption Surface-Ionization Spectroscopy	P015, P016
Atomoxetine	O32
ATV	P161
Auto-Derivatization	P176
Automated On-Line DBS	P005
Automated SPE	P020
Automation	O96, P296
Autopsy	O102, P107, P124
Autopsy Specimens	O106

Keywords

B

BAC
Bacteria
Barbitone
Barbiturates

Bath Salts

Belgium
Benzhexol Hydrochloride
Benzodiazepines

Benzoylcegonine
Benzylpiperazine
Betahydroxybutyrate
Bile
Bioaffinity
Biochemical Methods
Biochip Array
Biomarkers
bk-MBDB
Blood

Blood Alcohol Concentration
Blood Alcohol Estimation
Blood Alcohol Stability
Blood Levels
Blood Spot
Blood Storage
Bonzai
Botulinum Toxin
Brain
Brazil
Buprenorphine
Buprenorphine Pharmacokinetics

Abstracts

P285
P122
P141
P027, P030,
P135, P222
O4, O90,
P082, P086,
P095
O2
P199
O24, O80,
P036, P058,
P113, P185,
P236, P257,
P282, P288,
P289
O82
P085
P117
P144
O59
P269
P223
P039, P179
P129
O37, O48,
P031, P043,
P044, P047,
P056, P101,
P124, P158,
P159, P160,
P290
P266
O54
P262
P147
P038
P262
P191
O93
P098
P297
P128, P223
P062

Keywords

Butalbital
BZP

C

Cadavers
Cannabidiol
Cannabimimetic(s)
Cannabinoid(s)

Cannabinoid Glucuronides
Cannabis

Cannabis Consumption Marker
Car Accidents
Carbohydrate Deficient Transferrin
(CDT)
Carboxy-THC
Cardiac Glycosides
Case Report(s)
Casework
Casework Validation
Cathinone(s)

Cathinone Derivatives
CDT
Chemical Contamination
Chemical Treatment
Chemical Warfare Agents
Cheminformatics
Chemistry
Child
Child Abuse
China
Chiral Capillary Electrophoresis
Chlorfenvinphos
Chlorphrifos
Chronic Alcohol Abuse
Chronic Exposure
Citalopram

Abstracts

P030
P085

O43
P022
P079, P080
A4, O3, O36,
O38, O75,
O84, O106,
P056, P144,
P193, P290
O10
O30, O38,
P044, P177,
P190, P229
P008
P266
P266, P268
P032
P002
P093, P131
A2
P159
O88, O92,
P089, P090,
P092, P254
P072
P227
O14
P271
O14
O11
P112
O83, P200
O19
O103
P196
P201
P220
O55, P263
O38
P151

Keywords

City and Country of San Francisco
Clenbuterol
Clinical and Postmortem Findings
Clinical Toxicology
Clonazepam
Clozapine

Coca Tea
Cocaine

Cocaine Adulteration
Cocaine Analytes
Cocaine-N-Oxide
Codacet
Codeine
Codeine-to-Morphine Ratio
Collaboration
Color Test
Colorimetric Assay Kit
Compliance Monitoring
Confirmatory Analysis
Co-Prescription
Cotinine
Crash
Creatinine
Cross-Reactivity
CS Teargas
Cut-Off
Cut-Off Concentration
Cutoffs
Cyamemazine
Cyanide
Cyanide Poisoning
CYP2D6

CYP450
Cyprus
Cytochrome
Cytochrome P450

Abstracts

P283, P299,
P300

P219
P168
O15
O37
P111, P146,
P170, P221

O82
A5, O13, O28,
O62, O82,
P011, P156,
P177, P198,
P240, P243
P216
P250
P256
P015
O100, P127
O78
P094
P123
P212
O29
P058
P226
P215
O5
P188
P234
P233
P281
P257
P160
P111
P101, P123
P238
O78, P150,
P152
O46
P149
O92
O34

Keywords

D

d₆-ethanol
DART-AccuTOF™
Darvon Cocktail
Data Exchange
Database
Database Analyses
Date Rape
Datura
DBS
DEA Scheduling
Death
Deconvolution
Degradation
Degradation Product
Delorazepam
Delta-9-Tetrahydrocannabinol
Denmark
Designer Drug(s)

Designer Stimulant Metabolites
Designer Stimulants
DESI-MS
Desoxy D2PM
Detection Times
DFSA
DFSA
Diabetic Ketoacidosis
Diagnosis
Diagnostic Performance
Diazinon
Dichloromethane
Diphenhydramine
Direct Injection
Direct LC-MS/MS Analysis
Direct Mass Spectrometry
Disialotransferrin
Disposable Pipette Extraction
(DPX)
Distribution
Diving

Abstracts

P274
O11
P108
P029
O11
P178
P282
P134
O12, P203
P173
P141
P034
P294
O18
P053
P242
P287
P072, P074,
P082, P083,
P085, P088,
P089, P192

P097
P099
O89
P094
O27
O60, P282
P282
O50
P220
O53
P220
P148
P014
P036
P005
P033
P268
P156

P155
P143

Keywords

Doping
Doping Control
Doxepin
DPX
Draeger Drug Test
Dried Blood Spots

Driver Profile
Drivers
Driving Ability Diagnostics
Driving Fitness
Driving Impairment
Driving Under the Influence

Driving Under the Influence of
 Drugs (DUID)
Drug Analysis
Drug Confirmatory Analysis
Drug Facilitated Crime
Drug Facilitated Sexual Assault
Drug Interaction
Drug Panel Reader
Drug Screening
Drug Screening Library
Drugged Driving (DUID)
DrugMan
Drugs

Drugs and Driving
Drugs and Toxic Compounds
Drugs of Abuse (DOA)

Drugs of Abuse Testing
Drugs Screening
Drunk Driving
DUI
DUID

Abstracts

P194, P278
O58
P130
P075
O3
O52, P005,
P209, P261
P285
P157
O72
O55
P251
P244, P293,
P298
O7

P010
O98
O17, P279
P283
P067
P186
O66, P138
P041
O6, P301
P138
O8, P038,
P143, P287,
P293, P295,
P297
O94
P060
O27, O81,
O96, P020,
P030, P066,
P086, P121,
P175, P184,
P186, P223,
P247, P248,
P296
O16, P180
P260
P285
P289
O1, O4, O8,
P107, P252,
P286, P287,
P288, P292,
P295, P301,
P302

Keywords

E

Ecstasy
Egypt
Elderly Mistreatment
ELISA

Embalmed
Emergency Toxicology Screening
EMIT
Enantiomer(s)
Endogenous GHB
Enforcement
England
Enzymatic Methods
Ephedrine
Epimer Chromatographic
 Separation
Epitestosterone
ESI
Esterified Anabolic Steroids
EtG
Ethanol

Ethanol Biomarkers
Ethyl Glucuronide
 (Ethylglucuronide)

Ethylmorphine
Ethyl-Sulfate
European Yew (*Taxus Baccata*)
Exact Mass Qualifier Ion
Exactive
Exhaled Breath
Expectoration

Abstracts

O44
P114
P241
O26, P012,
P013, P014,
P085, P154,
P158, P159,
P160, P246,
P260
P170
O16
P260
P046, P151
P281
P293
P292
P269
P033
P276
P276
P017
P194
O53
A6, O8, O45,
P137, P230,
P265, P267
P263
A6, O51, O52,
O55, P230,
P263, P264,
P265, P270,
P272
P152
O51
P105
O74
P236
O30
P291

Keywords

F

Fatal Intoxication	O20
Fatal Poisoning	O47, P105, P148
Fatality	P161
Fatally-Insured Drivers	O5
Felony DUI	P299
Fentanyl	O99, P133
Flash Chromatography	P006, P197
Fluorescent Immunoassay	P202
Fluoroamphetamines	O9
Forensic	O49, P127
Forensic Alcohol Analysis	P299, P300
Forensic Blood	P034
Forensic Blood Sample	O9
Forensic Science	A3
Forensic Toxicokinetics	O103
Forensic Toxicology	P109, P135, P153, P167, P225
Formic Acid	O105
Fully Automated Sample Preparation	P054
Fungi	O43

G

Gamma Hydroxybutyrate	P231
Gamma-Hydroxybutyric Acid	P061
Gas Chromatography/Mass /Spectrometry	P097, P099
GC & LC-MS	O83
GC/LC-MS	P064
GC+GC	P277
GC-EI-MS	O12
GC-MS	O39, P034, P037, P048, P091, P093, P138, P144, P145, P166, P195, P198, P240, P248, P249, P282, P302

Abstracts

Keywords

GC-MS/MS	P077, P265
GC-TOFMS	P176
Gender Differences	P062
General Unknown	O61
Genetic Variants	P227
Genotyping	P151
GHB	O12, P001, P280
GHB Metabolites	P046
Glaucine	O34
Glucuronide	P026
Glucuronide Metabolites	O60
Glyphosate	P019
Graph-Based Visualization	P192
Gravidity	P208
Guidelines	P180

H

H ₂ S	P116
Hair	A5, O19, O24, O26, O28, O53, O67, P011, P145, P239, P250, P256, P258, P259, P270, P271
Hair Analysis	O55, O62, O78, O80, O91, P241, P245, P247, P248, P254, P255, P264
Hair Samples	O65
Hallucinogens	O79
Hanging	P169
Hazardous Jobs	P177
Head-Space	P198
Helium	P118
Hemorrhagic Necrosis	P137
Hepatotoxicity	P065
Herbal Blend	P042
Herbal Incense "Buzz"	P079
Heroin Drought	O95
Heroin Overdose	P165

Keywords

HFC-152a
High Resolution Mass Spectrometry
High Temperature Vaporization
High Throughput
High-Resolution Mass Spectrometry
HILIC
Histopathology
Homicidal Poisoning
Homicide
Homogeneous Immunoassay
Horse Liver
HPLC
HPLC/MS/MS
HPLC-DAD
HPLC-MS/MS
HPLC-UV Analysis
HRAM
HS-GC/MS
Human Hair
Human Metabolism
Human Urine
Human Urine
Hybrid Mass Spectrometry
Hydroxyacid-Oxoacid Transhydrogenase
Hydroxylamine
Hydroxyzine
Hyperglycemia
Hyperosmolar Hyperglycemic State

I

Identification
Imidazole Cyclodextrin
Immunoassay(s)
Immunohistochemistry
Impairment
In Vitro
In Vitro Assay
In Vitro-In Vivo Correlation
In Vivo

Abstracts

P155
O28, P274
P010
P003, P004
P074
P031
P102
P104
O22, O85
P018
O41
P119
P296
O57
P255
P227
P236
P118
O79
P216
P097, P099
P099
P043, P044
P231
P049
P057
O101
O50

Keywords

Incomplete Absorption
Inhalant Exposure
Injured Drivers
Intercept
Intermediate Syndrome
Internet
Interpretation
Intoxication

Intra Uterine Growth Restriction
Intravenous Administration
Ion Trap MS/MS
IRMS
Isolation
Isopropanol
i-STAT
Italian Law
ITSP
IUGR

J

Japan
JWH
JWH Synthetic Cannabinoids
JWH-018

JWH-073

JWH-175
JWH-250

K

K2
Ketamine
Keto Analytes

Abstracts

O54
P155
O2
P291
P200
P108
O45
P081, P115,
P126, P147,
P164, P208,
P218, P221,
P273
O31
O33
P084
P277
P006
P217
P112
P177, P183
P296
O31

P190
P191, P193
P070
A3, O1, O65,
P076, P078,
P079, P080
A3, P076,
P078
O69
A3, P071

P073, P077
O26
P049

Keywords

L

Laboratory P141
Laboratory Analyses P174
Laboratory Automation P029
LC-ESI-MS/MS O52, O70,
P129
LC-MS O56, O57,
O60, O91,
P036, P122,
P220
LC-MS/MS O10, O24,
O26, O30,
O32, O37,
O39, O51,
O63, O64,
O66, O67,
O68, O72,
O76, O77,
O101, P001,
P017, P021,
P024, P026,
P030, P040,
P046, P047,
P059, P060,
P075, P078,
P083, P089,
P092, P095,
P098, P105,
P113, P126,
P140, P175,
P179, P202,
P203, P207,
P219, P221,
P228, P250,
P254, P256,
P261, P264,
P267
LC-MS-MS Analysis P183
LC-TOF P124
LC/TOF-MS O74
LDTD-MS/MS P003, P004
Legal Highs O66, P089,
P192, P195
Leptin P229
Lethal Intoxication P110
Levamisole O13, O28,
P216

Abstracts

Keywords

Library O87
Library Search P040
Lidocaine P224
LIMS P029
Liquid Chromatography P124
Liquid Chromatography-Mass
Spectrometry O61
Liquid Chromatography-Time of
Flight Mass Spectrometry O16
Liquid Handling P054
Liver P133, P163
Lorazepam P053
Loss by Solvent Evaporation P087
Loxapine P111
LXQ O87

M

Maintenance O21
MALDI LTQ Orbitrap P011
MALDI-MSI O62
MALDI-TOF P042
Marijuana O25, P211
Markers P048
Mass Analysis P007
Mass Spectrometry O88, P056,
P073, P124,
P193
Matrix Effects O23, O81
MBTFA P37
m-CPP P228
MDMA A1, O17, O22,
O35, O42,
P065, P068,
P069, P291
MDPV O90, P082,
P084, P088,
P095
Meconium P240, P258
Medical Review Officer P178
Medico-Legal Cases P195
Memory O42

Abstracts

Keywords

Meperidine P222
Mephedrone P092, P095,
P098, P126
P302
Mephedrone / MDPV O4
Mephedrone Analogue P091
Metabolism O34, O40,
O41, O43,
O92, P066,
P122
Metabolites O63, O65,
P071, P245
Meta-Chlorophenylpiperazine P228
Methadone O19, O21,
P004, P107,
P121, P140,
P147, P154,
P172, P218,
P226, P234,
P239, P298
Methamphetamine P067, P068,
P069, P243,
P258
Methanol Intoxication P137
Methanol Poisoning O105
Methcathinone P093
Methcathinone Analogs P086, P087
(Analogues)
Methemoglobinemia P233
Methodological Approach O7
Methoxyamine P162
Methoxyimino P162
Methylamphetamine P196
Methylenedioxymethamphetamine O44
Methylethylketone P217
Methylglyoxal O101
Methylphenidate P045
Mibolerone P064
Microbial Ethanol P125
Microwave Assisted Extraction P109
(MAE)
Misdemeanor DUI P300
Misoprostol Acid P206
Model P125
Model Law O6
Morphine O48, P132
Multidisciplinary O19
Multi-Drug Screening O59

Abstracts

Keywords

Multi-Target Screening P083
Murder P131
Myocardial Damages P165

N

N,N-Dimethyltryptamine P021
Nalbuphine P063
Nano LC/MS O59
Naphyrone P084
Neutropenia O28
New Drugs O91
Nicotine O58
Nicotine Metabolites P215
Nitrite O97
Nitrogen Mustards P039
Nitrogen Narcosis P143
NLCP P182
NMR P091
Non-Biological Analysis P279
Norclozapine P146
Normeperidine P222
Northern Greece P218
Novel Drug P094
Novel Drug Analogues O89

O

O-Chlorobenzylidene P233
Malononitrile
Olanzapine O18
On-Line SPE P009
On-Site Testing P252
Operational P096
Opiates O95, O97,
P052, P058,
P145, P243
Opioid(s) O47, P162,
P209, P246
Optimization P037

Abstracts

Keywords

Oral Fluid

Oral Fluid Collection

Oral/Intravenous
Methamphetamine

Orbitrap®

Organophosphate(s)

Overdose

Overdose and Toxicology

Oxymorphone

P

Pain Management

Pain Patient Population

Paper Spray Ionization

Para-Methoxymethamphetamine

Passive Exposure

PCP

Pentobarbital

Per Se Drugged Driving

Perfusion

Pesticide(s)

Phallotoxins

Pharmaceutical Drugs

Pharmacodynamic Drug-Drug
Interaction

Pharmacogenetic

Pharmacokinetic(s)

Pharmacokinetic Drug-Drug
Interaction

Abstracts

A1, A4, O3,
O25, O27,
O29, O32,
O36, O37,
O64, O68,
O82, O84,
O94, O95,
P012, P171,
P243, P244,
P246, P251,
P252, P253,
P257, P291

O23, O81

P166

O88, P074

P019, P102,
P200, P220

P136, P168,
P170, P214

O21

P164

P013, P028,
P210

P226

O94

O20

O25

P243

P030, P109

O6

O45

P104, P220

P024

P241

P069

P152

A1, O33,
O100, P067

P068

Keywords

Phase II Metabolites

Phenazepam

Phenobarbital

Phenolphthalein

Phosphatidylethanol

Placenta

Plasma

PMMA

Poisoning

Poisoning Death

Poisons

Poly(N-isopropylacrylamide)

Polyclonal Antibody

Poly-Drug Detection

Portable Devices

Postmortem (Post-Mortem)

Post-Mortem Blood

Postmortem Concentrations

Postmortem Distribution

Postmortem Drug Screen

Postmortem Peripheral Blood

Postmortem Peripheral Blood
Concentrations

Postmortem Redistribution

Postmortem (Post-Mortem)
Toxicology

Postmortem Whole Blood

p-phenylenediamine

Prediction

Pregnancy

Prenatal Exposure

Abstracts

O35

P286

P030

P213

O56, O77,
P261, P274

O51

O10, O39,
O75, P021,
P098, P219,
P228

O20

P102, P134,
P201

P142

O103

P002

P224

O94

P251

A6, O85, O90,
P116, P117,
P120, P121,
P129, P136,
P139, P154,
P164, P167

P125

P146

P130

O104

O99

P172

O44, O106,
P133

O14, O47,
O100, P128,
P148, P286

P135

P114

O73

P237, P239

O80

Keywords

Prevalence
Prevalence Alcohol/Psychoactive
Substance
Prison
Probation
Proficiency Test
Project STOP
Propoxyphene
Protein Adducts
Proteomics
Psilocin
Psychoactive
Psychoactive Medications
Pubic Hair
Pulmonary Hypertension
Pulverizing Versus Cutting
Pupae
Putrefaction
Putrefaction
Pyrolysis
Pyrolysis-Gas Chromatography /
Mass Spectrometry

Q

qNMR
QTOF-MS
Qtrap
Qualifier Ions
Quality Management
Quantification
Quotas

R

Rapid Drug Screening
Rapid Screening
Rat(s)
Rat Model
RAVLT
Reference Compounds
Reference Ranges

Abstracts

O29, P171,
P287
O2
P205
P211
P247
P196
P003
P039
O31
P207
P096
O5
P242
O13
P270
P140
O105, P063
P063
P048, P179
A5
P026
O60
O87
P176
P174
P060
P173
O86
P007
A6, O93
P065
O42
P197
P120

Keywords

Residue
Retention Time
Reversed Phase HPLC and C18
Reversed Phase Column
Ritalinic Acid
Roadside Testing
RX Series

S

Saliva
SAMHSA
Sample Preparation
San Francisco
Scopolamine
Screen(ing)
Screening Library
Screening Method
Secobarbital
Segmental Hair Analysis
Segmented Hair Analysis
Serotonergic Drugs
Serum
Sexual Enhancement Products
Sibutramine
Single Hair
Skeletal Tissue
Social Drinking
Society of Hair Testing
Solid Phase Micro Extraction
Solid Phase Microextraction
Technique
Solvents Intoxication
Southern Finland
SPE
SPE Cartridges
Specific Gravity
Specimen Validity Testing

Abstracts

P103
O73
P199
P045
P285
P212
P025, P249,
P267
P175, P181
P050, P051,
P052, P185
O22, P172,
P298
P134
O57, O76 ,
P047, P139
P059
O15
P030
O17
O83
O46
O69, O70
P280
P213
P011
P167
O54
P247
P253
P010
P217
P285
O39, P001,
P030, P049
P035
P188
P188

Keywords

Spice
Stability
Statistical Elaboration
Steroids
Stimulants
Stomach Contents
Structural Isomers
Strychnine
Suboxone
Substances of Abuse
Succinic Semialdehyde
Sufentanil
Suicide
Sulfonylurea
Sulpiride
Supported Liquid Extraction
Surface Ionization Mass Spectrometry
Switzerland
Synthetic Cannabinoid (Spice, K2)
Synthetic Cannabinoids
Synthetic Urine
Systematic Toxicological Analysis (STA)

Abstracts

O64, P071, P073, P077, P191, P193
O18, O75, P063, P090, P207
P272
O40, P277
P088, P171
P166
O73
P163
P210
P174
P231
P013
P108, P110, P114, P118, P123, P142, P169
P119
P130
P044, P050, P051, P052, P185
P015, P016
P288
O69
A2, A3, O1, O63, O67, O68, O70, O71, P042, P044, P072, P075, P076, P078, P081, P191, P197
P187
P009, P138

Keywords

T

Tablets
Tandem Mass Spectrometry
Tapentadol
Target Screening
Teargas Toxicity
Teeth
Testosterone
Testosterone/Epitestosterone Urinary Ratio
Tetrahydrocannabinol
Thailand-Myanmar Border
THC
THCA-A
THC-COOH
Therapeutic Drug Monitoring
Thermal Degradation
Thermoresponsive
Thiethylperazine
Thiosulphate
Thyroid Storm
Time-of-Flight Mass Spectrometry
TiO-C₁₈ Monolithic Spin Column
Tissue Distribution
Tobacco
TOF LC/MS
TOF-MS
Toxicity
Toxicokinetics
Toxicological Analysis
Toxicological Investigation
Toxicological Screening
Toxicology
TOXI-LAB
Traffic Accidents

P163
P055, P101, P204
P012, P018, P234
P203
P233
P109
O39, P276
P278
A4, O23, O36, O84
P280
O75, P027, P190, P243, P253
P008
P035, P051
P204
P087
P002
P208
P116
P115
O61
P019
P063, P119
P215, P237
O69, O86
O26
P128
O93, P103
P211
O7
P249
O49, P027, P084, P120, P127, P149, P205
P214
P157

Keywords

Traffic Safety
Tramadol
Transdermal Patch
Treatment
Tricyclic Antidepressants
Trifluoroacetic Anhydride
Trimethylbenzenes
Truck Drivers
Turbulent Flow
Turbulent Flow Chromatography

U

UDP-Glucuronosyltransferase
(UGT)
UHPLC
UHPLC-DAD
U-HPLC-MS
Unknown Toxicological Analytes
Identification
Unnatural Deaths
UPLC
UPLC Mass Spectrometry
UPLC®-MS
UPLC-MS/MS

UPLC-MS/TOF
UPLC-QTOF/MS
Uric Acid / Creatinine Ratio
Urinary Metabolism
Urine

Urine Drug Screening
Urine Immunoassay Testing
Urine Screen Cutoff
Urine Toxicology
UV Spectrophotometer

Abstracts

P289
P245, P255
O99
O21
P202, P223
P022
P201
P297
P028
O72, P017

P230
O58
P194
P236
P059
P149
P055
O104
P032, P181
O9, P025,
P057, P206,
P213, P259,
P281, P290
O15
P020
P187
P064
O39, O40,
O71, O76,
P007, P018,
P028, P032,
P033, P035,
P113, P181,
P184, P205,
P219, P228,
P236
O74
P186
O98
P283
P104

Keywords

V

Validation
Valproic Acid
Venlafaxine
Violent Crimes
Vitreous
Vitreous Humor

VMA-T Reagent

W

Wales
Whole Blood

Whole Blood Comparison
Widmark Method
Widmark's Equation
Workplace Drug Test(ing)

Workplace Urine Drug Testing

X Y Z

XLC-QqTOF
Xylazine
Z-Drugs
Zolpidem

Zopiclone

Abstracts

O71, P043
P168
P150
P225
A6, O48
P112, P153,
P156
P260

P292
A2, O75, O86,
O96, P054,
P090, P206
P209
P269
P273
O98, P178,
P182, P183,
P187
P177

P009
P057
P288
O49, P131,
P289
O49, P289,
P294